

Linear Building Block – Low Power Voltage Reference with Programmable Hysteresis Comparator and Shutdown

Features

- Combines Comparator and Voltage Reference in a Single Package
- Optimized for Single Supply Operation
- Small Package: 8-Pin MSOP
- Ultra Low Input Bias Current: Less than 100pA
- Low Quiescent Current, Active: 6 μ A (Typ.), Shutdown Mode: 0.1 μ A (Typ.)
- Rail-to-Rail Inputs and Outputs
- Operates Down to $V_{DD} = 1.8V$
- Programmable Hysteresis

Applications

- Power Management Circuits
- Battery Operated Equipment
- Consumer Products

Device Selection Table

Part Number	Package	Temperature Range
TC1031CEUA	8-Pin MSOP	-40°C to +85°C

Package Type

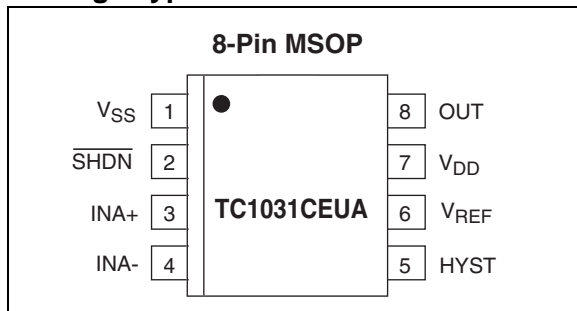

General Description

The TC1031 is a low-power comparator and voltage reference designed specifically for low-power applications. The TC1031 is designed for operation from a single supply, however operation from dual supplies is also possible. The power supply current drain is independent of the magnitude of the power supply voltage. The TC1031 can operate from two 1.5V alkaline cells, and operation is ensured to $V_{DD} = 1.8V$. Typical active supply current is 6 μ A. Rail-to-rail inputs and outputs allow operation from low supply voltages with large input and output signal swings.

The TC1031 provides a simple method for adding user-adjustable hysteresis without feedback or complex external circuitry. Hysteresis is adjusted with a simple resistor divider on the HYST input. A shutdown input, SHDN, disables the comparator and voltage reference and reduces supply current to less than 0.1 μ A (maximum) when taken low.

The TC1031 is packaged in a space-saving 8-Pin MSOP, making it ideal for applications requiring high integration, small size and low power.

Functional Block Diagram

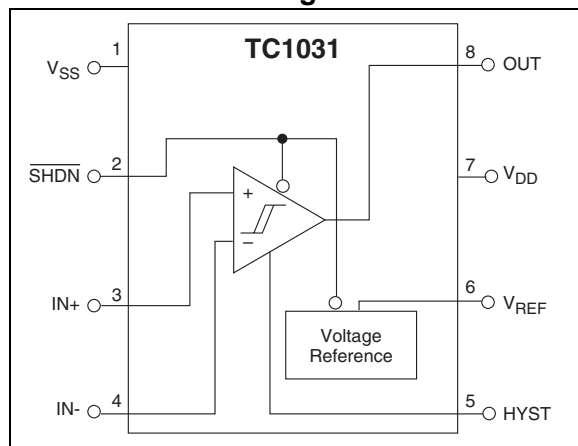

TC1031

1.0 ELECTRICAL CHARACTERISTICS

ABSOLUTE MAXIMUM RATINGS*

Supply Voltage	6.0V
Voltage on Any Pin	($V_{SS} - 0.3V$) to ($V_{DD} + 0.3V$)
Junction Temperature	+150°C
Operating Temperature Range.....	-40°C to +85°C
Storage Temperature Range	-55°C to +150°C

*Stresses above those listed under "Absolute Maximum Ratings" may cause permanent damage to the device. These are stress ratings only and functional operation of the device at these or any other conditions above those indicated in the operation sections of the specifications is not implied. Exposure to Absolute Maximum Rating conditions for extended periods may affect device reliability.

TC1031 ELECTRICAL SPECIFICATIONS

Electrical Characteristics: Typical values apply at 25°C and $V_{DD} = 3.0V$; $T_A = -40^\circ$ to $+85^\circ C$, and $V_{DD} = 1.8V$ to $5.5V$, unless otherwise specified.						
Symbol	Parameter	Min	Typ	Max	Units	Test Conditions
V_{DD}	Supply Voltage	1.8	—	5.5	V	
I_Q	Supply Current, Operating	—	6	10	μA	All Outputs Open, $\overline{SHDN} = V_{DD}$
I_{SHDN}	Supply Current, Shutdown	—	—	0.1	μA	$\overline{SHDN} = V_{SS}$
Shutdown Input						
V_{IH}	Input High Threshold	80% V_{DD}	—	—	V	
V_{IL}	Input Low Threshold	—	—	20% V_{DD}	V	
I_{SI}	Shutdown Input Current	—	—	± 100	nA	
Comparator						
$R_{OUT} (SD)$	Output Resistance in Shutdown	20	—	—	$M\Omega$	$\overline{SHDN} = V_{SS}$
$C_{OUT} (SD)$	Output Capacitance in Shutdown	—	—	5	pF	$\overline{SHDN} = V_{SS}$
T_{SEL}	Select Time	—	20	—	μsec	V_{OUT} Valid from $\overline{SHDN} = V_{IH}$ $R_L = 10k\Omega$ to V_{SS}
T_{DESEL}	Deselect Time	—	500	—	nsec	V_{OUT} Invalid from $\overline{SHDN} = V_{IL}$ $R_L = 10k\Omega$ to V_{SS}
V_{ICMR}	Common-Mode Input Voltage Range	$V_{SS} - 0.2$	—	$V_{DD} + 0.2$	V	
V_{OS}	Input Offset Voltage (Note 1)	-5	—	+5	mV	$V_{DD} = 3V$, $V_{CM} = 1.5V$
I_B	Input Bias Current	—	—	± 100	pA	$T_A = 25^\circ C$ $IN+, IN- = V_{DD}$ to V_{SS}
V_{OH}	Output High Voltage	$V_{DD} - 0.3$	—	—	V	$R_L = 10k\Omega$ to V_{SS}
V_{OL}	Output Low Voltage	—	—	0.3	V	$R_L = 10k\Omega$ to V_{DD}
CMRR	Common Mode Rejection Ratio	66	—	—	dB	$T_A = 25^\circ C$, $V_{DD} = 5V$ $V_{CM} = V_{DD}$ to V_{SS}
PSRR	Power Supply Rejection Ratio	60	—	—	dB	$T_A = 25^\circ C$, $V_{DD} = 1.8V$ to $5V$ $V_{CM} = 1.2V$
I_{SRC}	Output Source Current	1	—	—	mA	$IN+ = V_{DD}$, $IN- = V_{SS}$ $V_{DD} = 1.8V$, Output Shorted to V_{SS}
I_{SINK}	Output Sink Current	2	—	—	mA	$IN+ = V_{SS}$, $IN- = V_{DD}$, $V_{DD} = 1.8V$, Output Shorted to V_{DD}
V_{HYST}	Voltage Range at HYST Pin	$V_{REF} - 0.08$	—	V_{REF}	V	
I_{HYST}	Hysteresis Input Current	—	—	± 100	nA	
t_{PD1}	Response Time	—	4	—	μsec	100mV Overdrive; $C_L = 100pF$
t_{PD2}	Response Time	—	6	—	μsec	100mV Overdrive; $C_L = 100pF$

Note 1: V_{OS} is measured as $(V_{UT} + V_{LT} - 2V_{REF})/2$ where V_{UT} is the upper hysteresis threshold and V_{LT} is the lower hysteresis threshold with $V_{REF} - V_{HYST}$ set to 10mV. This represents the asymmetry of the hysteresis thresholds around V_{REF}

TC1031 ELECTRICAL SPECIFICATIONS (CONTINUED)

Electrical Characteristics: Typical values apply at 25°C and $V_{DD} = 3.0V$; $T_A = -40^\circ$ to $+85^\circ C$, and $V_{DD} = 1.8V$ to $5.5V$, unless otherwise specified.

Symbol	Parameter	Min	Typ	Max	Units	Test Conditions
Voltage Reference						
V_{REF}	Reference Voltage	1.176	1.200	1.224	V	
$I_{REF(SOURCE)}$	Source Current	50	—	—	μA	
$I_{REF(SINK)}$	Sink Current	50	—	—	μA	
$R_{OUT(SD)}$	Output Resistance in Shutdown	20	—	—	$M\Omega$	$\overline{SHDN} = V_{SS}$
$C_{OUT(SD)}$	Output Capacitance in Shutdown	—	—	5	pF	$\overline{SHDN} = V_{SS}$
T_{SEL}	Select Time	—	200	—	μsec	REF Valid from $\overline{SHDN} = V_{IH}$ $R_L = 100k\Omega$ to V_{SS}
T_{DESEL}	Deselect Time	—	10	—	μsec	REF Invalid from $\overline{SHDN} = V_{IL}$ $R_L = 100k\Omega$
$C_{L(REF)}$	Load Capacitance	—	—	100	pF	
E_{VREF}	Voltage Noise	—	20	—	μV_{RMS}	100Hz to 100kHz
e_{VREF}	Noise Density	—	10	—	$\mu V/\sqrt{Hz}$	1kHz

Note 1: V_{OS} is measured as $(V_{UT} + V_{LT} - 2V_{REF})/2$ where V_{UT} is the upper hysteresis threshold and V_{LT} is the lower hysteresis threshold with $V_{REF} - V_{HYST}$ set to 10mV. This represents the asymmetry of the hysteresis thresholds around V_{REF}

TC1031

2.0 PIN DESCRIPTIONS

The description of the pins are listed in Table 2-1.

TABLE 2-1: PIN FUNCTION TABLE

Pin No. (8-Pin MSOP)	Symbol	Description
1	V_{SS}	Negative power supply.
2	\overline{SHDN}	Shutdown input.
3	IN+	Comparator non-inverting input.
4	IN-	Comparator inverting input.
5	HYST	Adjustable hysteresis input.
6	V_{REF}	Voltage reference output.
7	V_{DD}	Positive power supply.
8	OUT	Comparator output.

3.0 DETAILED DESCRIPTION

The TC1031 is one of a series of very low-power, linear building block products targeted at low-voltage, single-supply applications. Minimum operating voltage for the device is 1.8V, and typical supply current is only 6μA (fully enabled). It combines one comparator and a voltage reference in a single package. The comparator and reference outputs are in a high-impedance state during shutdown.

3.1 Comparator

The TC1031 contains one comparator with programmable hysteresis. The range of the inputs extends beyond both supply voltages by 200mV. The comparator outputs will swing to within several millivolts of the supplies depending on the load current being driven.

The comparator exhibits a propagation delay and supply current which is largely independent of supply voltage. The low input bias current and offset voltage make it suitable for high impedance precision applications.

The comparator is disabled during shutdown and has high-impedance output.

3.2 Voltage Reference

A 2.0% tolerance, internally biased, 1.20V bandgap voltage reference is included in the TC1031. It has a push-pull output capable of sourcing and sinking at least 50μA. The voltage reference is disabled during shutdown, with a high-impedance output.

3.3 Shutdown Input

$\overline{\text{SHDN}}$ at V_{IL} disables both the comparator and voltage reference and reduces the supply current to less than 0.1μA. The $\overline{\text{SHDN}}$ input cannot be allowed to float; when not used, connect it to V_{DD} . The outputs are in a high impedance state when the TC1031 is disabled. The comparator's inputs and output can be driven from rail-to-rail by an external voltage when the TC1031 is disabled. No latching will occur when the device is driven to its enabled state when $\overline{\text{SHDN}}$ is set to V_{IH} .

3.4 Programmable Hysteresis

Hysteresis is added to the comparators by connecting a resistor R1 between the V_{REF} and HYST pins and another resistor R2 between the HYST pin and V_{SS} . For no hysteresis V_{REF} should be directly connected to HYST. The hysteresis, V_{HB} , is equal to twice the voltage difference between the V_{REF} and HYST pins, where:

$$V_{HB} = 2 * V_{REF} * R1 / (R1 + R2) \quad (\text{See Figure 3-1})$$

and is symmetrical around the normal (without hysteresis) threshold of the comparator. The maximum voltage allowed between the V_{REF} and HYST pins is 80mV, giving a maximum hysteresis of 160mV.

FIGURE 3-1: TC1031 PROGRAMMABLE HYSTERESIS

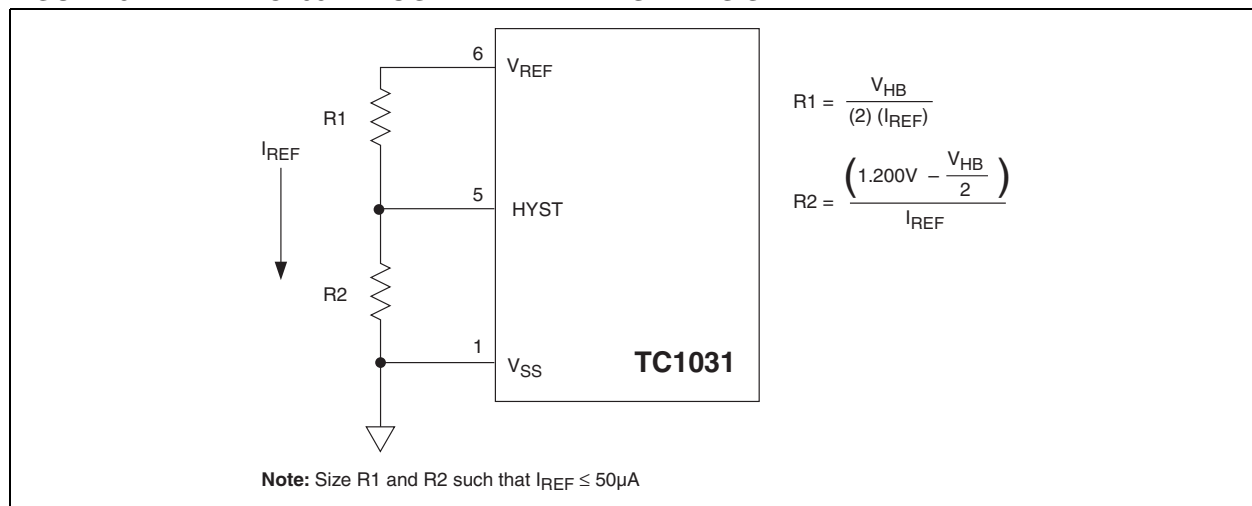

4.0 TYPICAL APPLICATIONS

The TC1031 lends itself to a wide variety of applications, particularly in battery-powered systems. It typically finds application in power management, processor supervisory and interface circuitry.

5.0 TYPICAL CHARACTERISTICS

Note: The graphs and tables provided following this note are a statistical summary based on a limited number of samples and are provided for informational purposes only. The performance characteristics listed herein are not tested or guaranteed. In some graphs or tables, the data presented may be outside the specified operating range (e.g., outside specified power supply range) and therefore outside the warranted range.

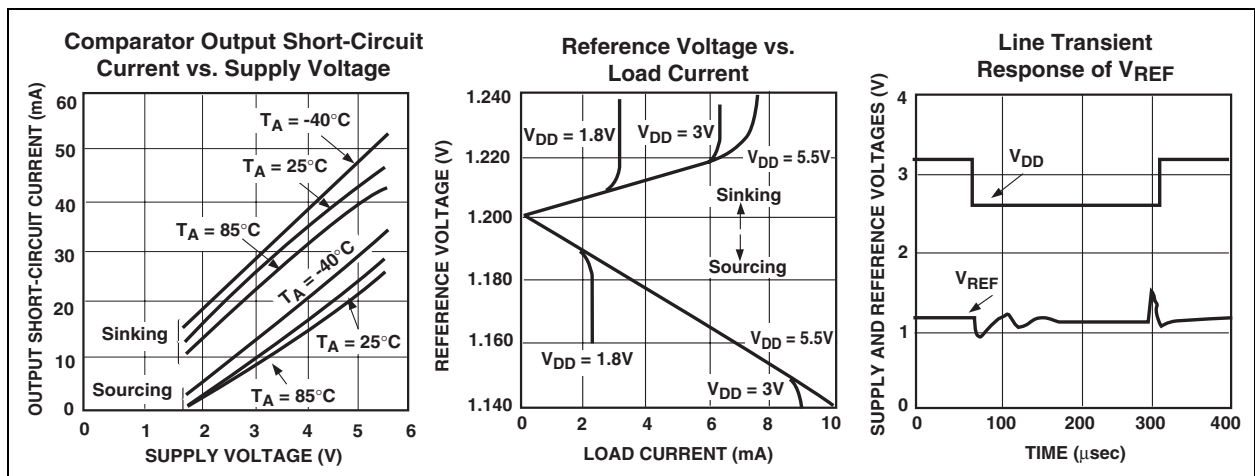
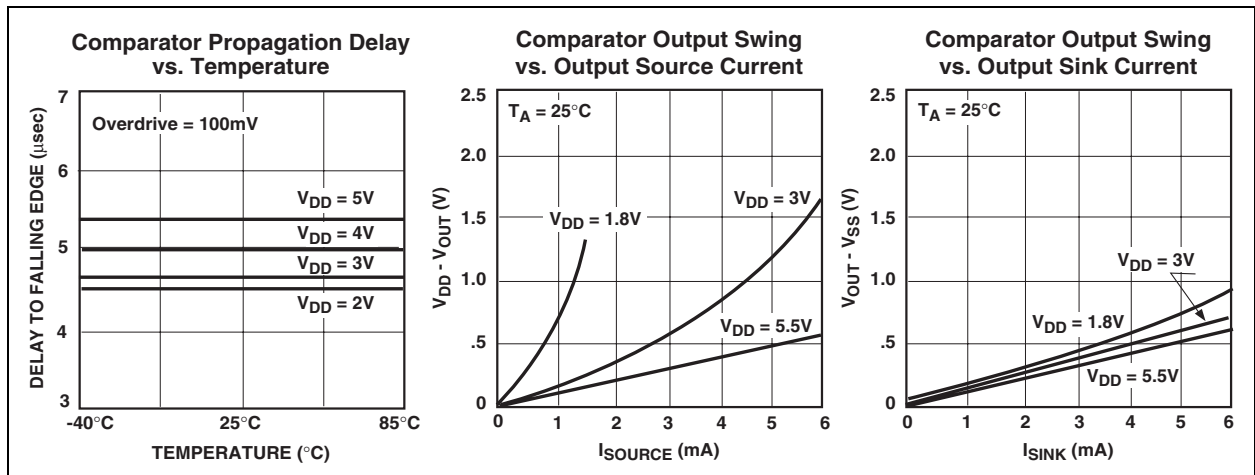
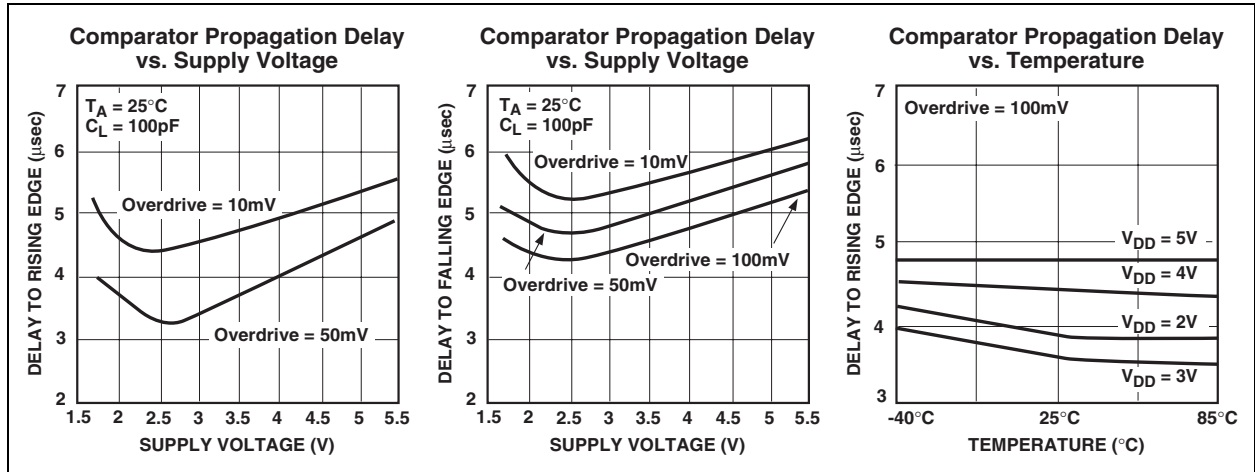

TC1031

5.0 TYPICAL CHARACTERISTICS (CONTINUED)

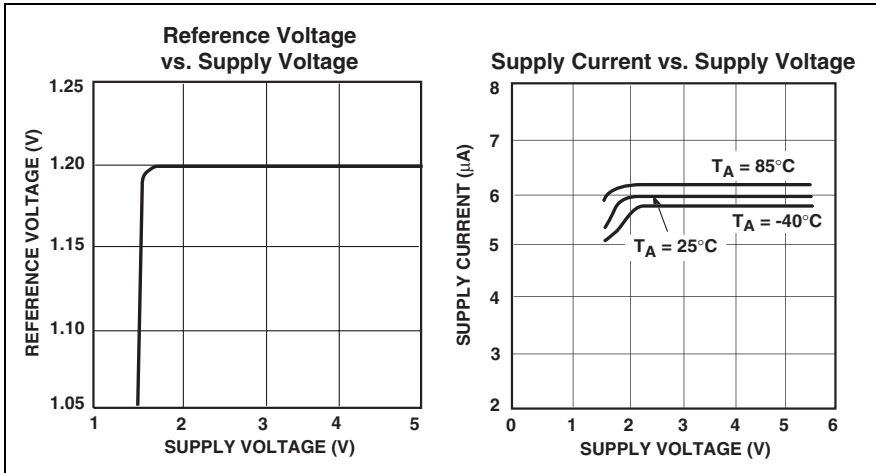

6.0 PACKAGING INFORMATION

6.1 Package Marking Information

Package marking data not available at this time.

6.2 Taping Form

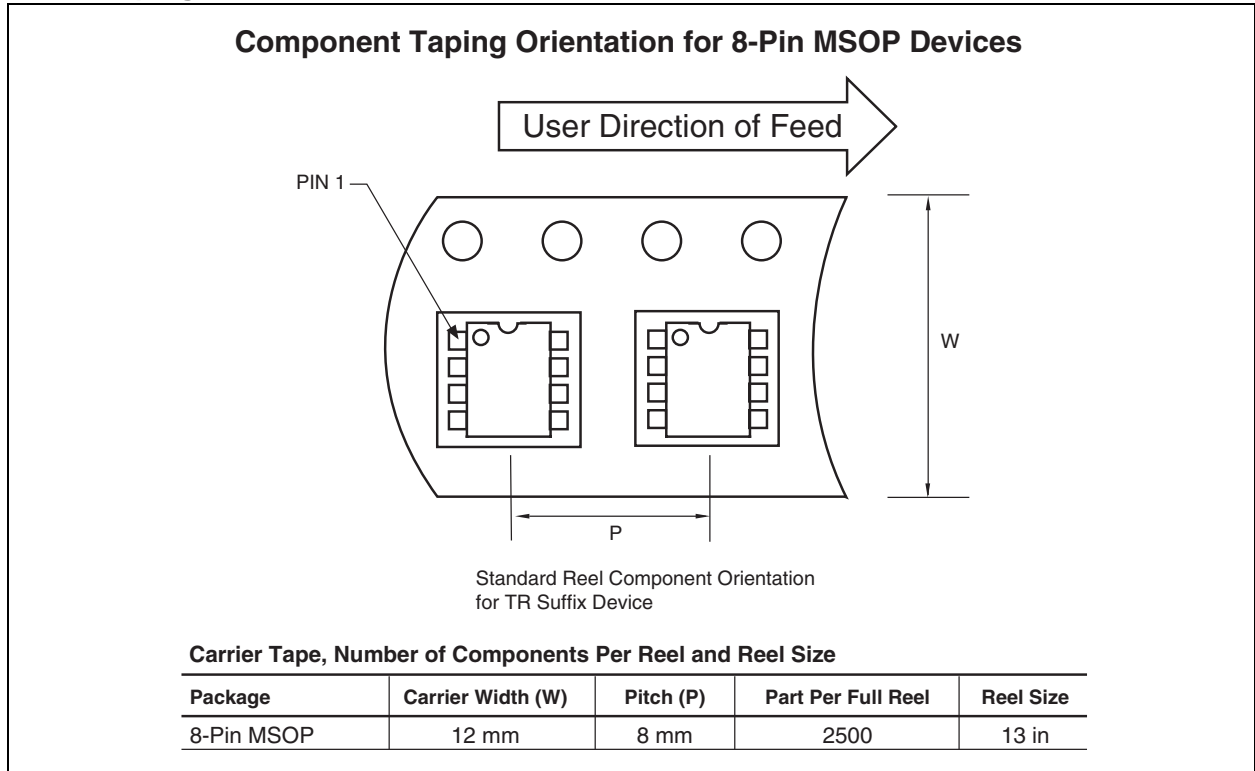

6.3 Package Dimensions

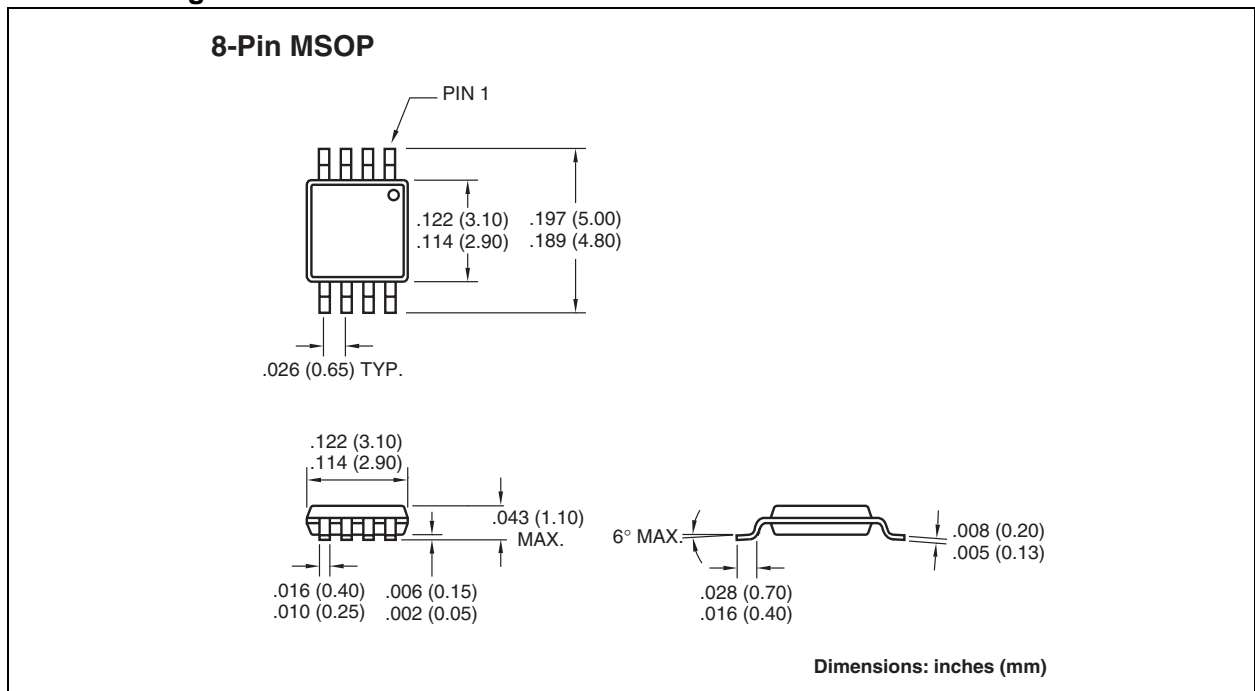

TC1031

NOTES:

Sales and Support

Data Sheets

Products supported by a preliminary Data Sheet may have an errata sheet describing minor operational differences and recommended workarounds. To determine if an errata sheet exists for a particular device, please contact one of the following:

1. Your local Microchip sales office
2. The Microchip Corporate Literature Center U.S. FAX: (480) 792-7277
3. The Microchip Worldwide Site (www.microchip.com)

Please specify which device, revision of silicon and Data Sheet (include Literature #) you are using.

New Customer Notification System

Register on our web site (www.microchip.com/cn) to receive the most current information on our products.

TC1031

NOTES:

Note the following details of the code protection feature on Microchip devices:

- Microchip products meet the specification contained in their particular Microchip Data Sheet.
- Microchip believes that its family of products is one of the most secure families of its kind on the market today, when used in the intended manner and under normal conditions.
- There are dishonest and possibly illegal methods used to breach the code protection feature. All of these methods, to our knowledge, require using the Microchip products in a manner outside the operating specifications contained in Microchip's Data Sheets. Most likely, the person doing so is engaged in theft of intellectual property.
- Microchip is willing to work with the customer who is concerned about the integrity of their code.
- Neither Microchip nor any other semiconductor manufacturer can guarantee the security of their code. Code protection does not mean that we are guaranteeing the product as "unbreakable."

Code protection is constantly evolving. We at Microchip are committed to continuously improving the code protection features of our products. Attempts to break Microchip's code protection feature may be a violation of the Digital Millennium Copyright Act. If such acts allow unauthorized access to your software or other copyrighted work, you may have a right to sue for relief under that Act.

Information contained in this publication regarding device applications and the like is provided only for your convenience and may be superseded by updates. It is your responsibility to ensure that your application meets with your specifications. MICROCHIP MAKES NO REPRESENTATIONS OR WARRANTIES OF ANY KIND WHETHER EXPRESS OR IMPLIED, WRITTEN OR ORAL, STATUTORY OR OTHERWISE, RELATED TO THE INFORMATION, INCLUDING BUT NOT LIMITED TO ITS CONDITION, QUALITY, PERFORMANCE, MERCHANTABILITY OR FITNESS FOR PURPOSE. Microchip disclaims all liability arising from this information and its use. Use of Microchip's products as critical components in life support systems is not authorized except with express written approval by Microchip. No licenses are conveyed, implicitly or otherwise, under any Microchip intellectual property rights.

Trademarks

The Microchip name and logo, the Microchip logo, Accuron, dsPIC, KEELoQ, microID, MPLAB, PIC, PICmicro, PICSTART, PRO MATE, PowerSmart, rPIC, and SmartShunt are registered trademarks of Microchip Technology Incorporated in the U.S.A. and other countries.

AmpLab, FilterLab, Migratable Memory, MXDEV, MXLAB, PICMASTER, SEEVAL, SmartSensor and The Embedded Control Solutions Company are registered trademarks of Microchip Technology Incorporated in the U.S.A.

Analog-for-the-Digital Age, Application Maestro, dsPICDEM, dsPICDEM.net, dsPICworks, ECAN, ECONOMONITOR, FanSense, FlexROM, fuzzyLAB, In-Circuit Serial Programming, ICSP, ICEPIC, Linear Active Thermistor, MPASM, MPLIB, MPLINK, MPSIM, PCKIT, PICDEM, PICDEM.net, PICLAB, PICtail, PowerCal, PowerInfo, PowerMate, PowerTool, rLAB, rPICDEM, Select Mode, Smart Serial, SmartTel, Total Endurance and WiperLock are trademarks of Microchip Technology Incorporated in the U.S.A. and other countries.

SQTP is a service mark of Microchip Technology Incorporated in the U.S.A.

All other trademarks mentioned herein are property of their respective companies.

© 2005, Microchip Technology Incorporated, Printed in the U.S.A., All Rights Reserved.

 Printed on recycled paper.

**QUALITY MANAGEMENT SYSTEM
CERTIFIED BY DNV
== ISO/TS 16949:2002 ==**

Microchip received ISO/TS-16949:2002 quality system certification for its worldwide headquarters, design and wafer fabrication facilities in Chandler and Tempe, Arizona and Mountain View, California in October 2003. The Company's quality system processes and procedures are for its PICmicro® 8-bit MCUs, KEELoQ® code hopping devices, Serial EEPROMs, microperipherals, nonvolatile memory and analog products. In addition, Microchip's quality system for the design and manufacture of development systems is ISO 9001:2000 certified.



WORLDWIDE SALES AND SERVICE

AMERICAS

Corporate Office
2355 West Chandler Blvd.
Chandler, AZ 85224-6199
Tel: 480-792-7200
Fax: 480-792-7277
Technical Support:
<http://support.microchip.com>
Web Address:
www.microchip.com

Atlanta

Alpharetta, GA
Tel: 770-640-0034
Fax: 770-640-0307

Boston

Westborough, MA
Tel: 774-760-0087
Fax: 774-760-0088

Chicago

Itasca, IL
Tel: 630-285-0071
Fax: 630-285-0075

Dallas

Addison, TX
Tel: 972-818-7423
Fax: 972-818-2924

Detroit

Farmington Hills, MI
Tel: 248-538-2250
Fax: 248-538-2260

Kokomo

Kokomo, IN
Tel: 765-864-8360
Fax: 765-864-8387

Los Angeles

Mission Viejo, CA
Tel: 949-462-9523
Fax: 949-462-9608

San Jose

Mountain View, CA
Tel: 650-215-1444
Fax: 650-961-0286

Toronto

Mississauga, Ontario,
Canada
Tel: 905-673-0699
Fax: 905-673-6509

ASIA/PACIFIC

Australia - Sydney
Tel: 61-2-9868-6733
Fax: 61-2-9868-6755

China - Beijing
Tel: 86-10-8528-2100
Fax: 86-10-8528-2104

China - Chengdu
Tel: 86-28-8676-6200
Fax: 86-28-8676-6599

China - Fuzhou
Tel: 86-591-8750-3506
Fax: 86-591-8750-3521

China - Hong Kong SAR
Tel: 852-2401-1200
Fax: 852-2401-3431

China - Qingdao
Tel: 86-532-8502-7355
Fax: 86-532-8502-7205

China - Shanghai
Tel: 86-21-5407-5533
Fax: 86-21-5407-5066

China - Shenyang
Tel: 86-24-2334-2829
Fax: 86-24-2334-2393

China - Shenzhen
Tel: 86-755-8203-2660
Fax: 86-755-8203-1760

China - Shunde
Tel: 86-757-2839-5507
Fax: 86-757-2839-5571

China - Wuhan
Tel: 86-27-5980-5300
Fax: 86-27-5980-5118

China - Xian
Tel: 86-29-8833-7250
Fax: 86-29-8833-7256

ASIA/PACIFIC

India - Bangalore
Tel: 91-80-2229-0061
Fax: 91-80-2229-0062

India - New Delhi
Tel: 91-11-5160-8631
Fax: 91-11-5160-8632

India - Pune
Tel: 91-20-2566-1512
Fax: 91-20-2566-1513

Japan - Yokohama
Tel: 81-45-471-6166
Fax: 81-45-471-6122

Korea - Gumi
Tel: 82-54-473-4301
Fax: 82-54-473-4302

Korea - Seoul
Tel: 82-2-554-7200
Fax: 82-2-558-5932 or
82-2-558-5934

Malaysia - Penang
Tel: 60-4-646-8870
Fax: 60-4-646-5086

Philippines - Manila
Tel: 63-2-634-9065
Fax: 63-2-634-9069

Singapore
Tel: 65-6334-8870
Fax: 65-6334-8850

Taiwan - Hsin Chu
Tel: 886-3-572-9526
Fax: 886-3-572-6459

Taiwan - Kaohsiung
Tel: 886-7-536-4818
Fax: 886-7-536-4803

Taiwan - Taipei
Tel: 886-2-2500-6610
Fax: 886-2-2508-0102

Thailand - Bangkok
Tel: 66-2-694-1351
Fax: 66-2-694-1350

EUROPE

Austria - Wels
Tel: 43-7242-2244-399
Fax: 43-7242-2244-393

Denmark - Copenhagen
Tel: 45-4450-2828
Fax: 45-4485-2829

France - Paris
Tel: 33-1-69-53-63-20
Fax: 33-1-69-30-90-79

Germany - Munich
Tel: 49-89-627-144-0
Fax: 49-89-627-144-44

Italy - Milan
Tel: 39-0331-742611
Fax: 39-0331-466781

Netherlands - Drunen
Tel: 31-416-690399
Fax: 31-416-690340

Spain - Madrid
Tel: 34-91-708-08-90
Fax: 34-91-708-08-91

UK - Wokingham
Tel: 44-118-921-5869
Fax: 44-118-921-5820