

**Preliminary**

Bi-CMOS Integrated Circuit Silicon Monolithic

# TB1239BF

## Luminance, Chroma and Synchronizing Signals Processor IC for PAL/NTSC/SECAM COLOR TV

TB1239BF integrates luminance, chroma and synchronizing signals processing circuits for PAL/NTSC/SECAM color TV system.

TB1239BF incorporates high performance picture quality compensation circuits in luminance section, an automatic PAL/NTSC/SECAM discrimination and decode circuits in chroma section, and an automatic 50/60 Hz discrimination circuit in synchronizing section.

Besides a crystal oscillator generates 4.43 MHz, 3.58 MHz and M/N-PAL clock signals internally for color demodulation. A horizontal PLL circuit is also built in this IC.

PAL/SECAM demodulation circuits which are adjustment-free circuits incorporates a 1 H DL circuit inside for operating the base band signal processing system.

Also, TB1239BF makes it possible to set and to control various functions through the built-in I<sup>2</sup>C BUS line.

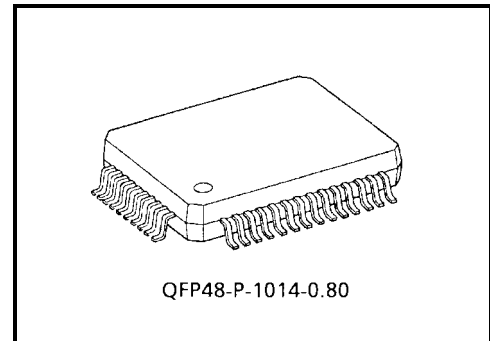

Weight: 0.83 g (typ.)

## Features

### Luminance Section

- Built-in chroma trap filter
- Black stretch circuit
- DC restoration circuit
- Y delay line
- Sharpness control
- Sub-Contrast control (-/+2dB)
- Black set-up for PAL plus

### Chroma Section

- Built-in 1 H delay circuit (PAL/SECAM base band demodulation system)
- One crystal color demodulation circuit (4.43 MHz, 3.58 MHz, M/N-PAL)
- Automatic system discrimination system and forced system mode
- 1 H delay line also serves as comb filter in NTSC demodulation
- Built-in band-pass and take-off filter, SECAM bell filter
- Sub-Color control (-/+2dB)

### Synchronizing Section

- Built-in horizontal VCO resonator
- Adjustment-free horizontal and vertical oscillation by count-down circuit
- Automatic vertical frequency discrimination circuit
- Noise detection circuit

**Others**

- Y/C out level control
- 4-channels inputs switching
- 2-input circuit for RGB
- 2-input circuit for Y/Cb/Cr
- Y/Cb/Cr outputs
- Cb/Cr offset adjustment
- Built-in pre filters for A/D converter

**Block Diagram**

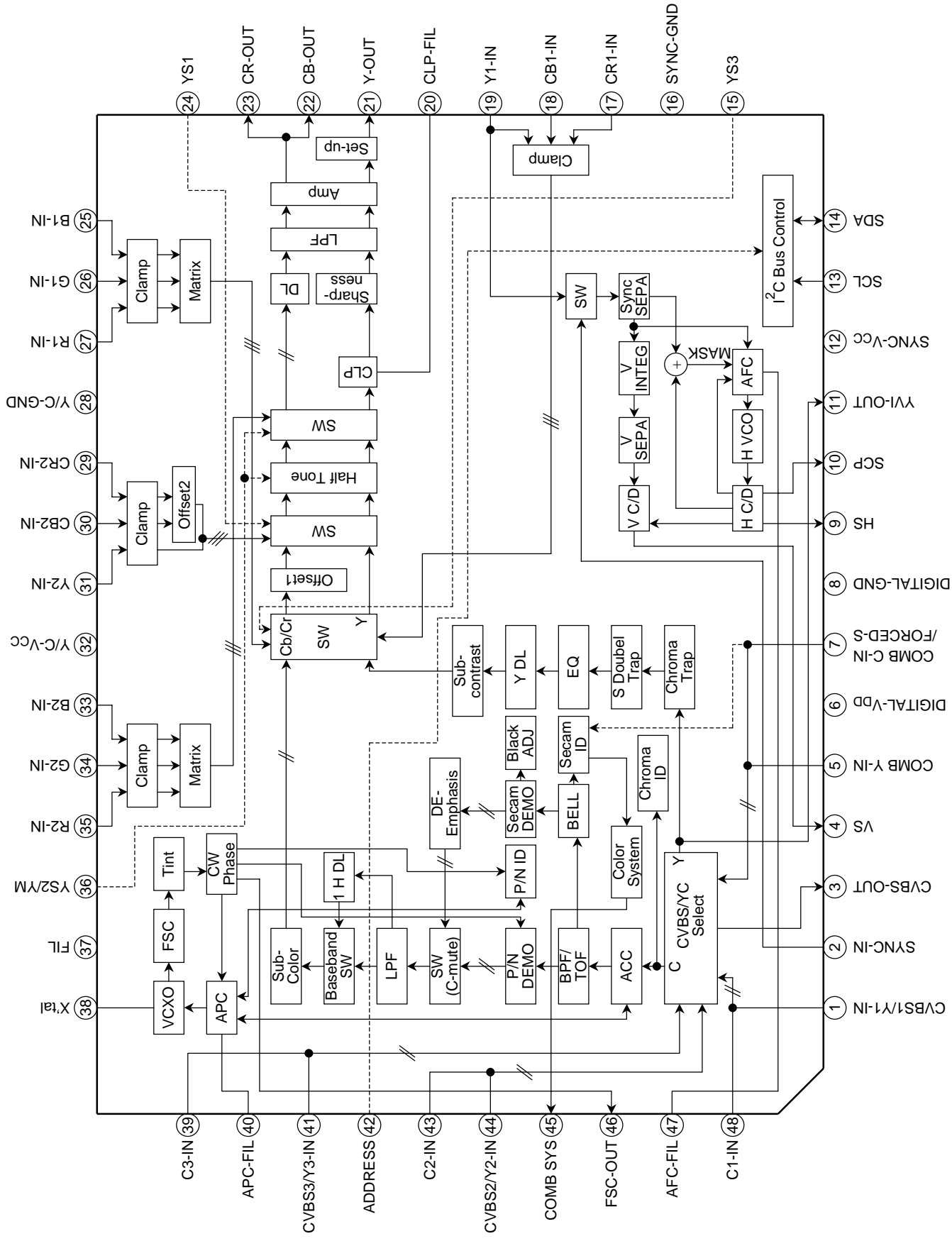

## Terminal Descriptions

(YC – V<sub>CC</sub>/SYNC – V<sub>CC</sub>/D – V<sub>DD</sub> = 5 V and Ta = 25°C, unless otherwise specified)

Pin No.	Pin Name	Function	Interface Circuit	Input/Output Signals
1	CVBS1/Y1-IN	Input CVBS1/Y1 signal through a clamping capacitor.		CVBS: 1 V <sub>p-p</sub> Y: 1 V <sub>p-p</sub> (with sync) DC: 1.8 V
2	SYNC-IN	Input signal to synchronize.		1 V <sub>p-p</sub> (with sync) DC: 1.7 V
3	CVBS-OUT	CVBS or Y + C signal output pin.		2 V <sub>p-p</sub> (with sync) DC: 0.6 V
4	VS	Output pin of vertical synchronizing signal. Minimum pull-up resistor is 6.8 kΩ.		 4.7 V ≤ Hi ≤ 5.2 V 0 V ≤ Low ≤ 0.8 V

Pin No.	Pin Name	Function	Interface Circuit	Input/Output Signals
5	COMB Y-IN	Input luminance signal from Comb filter through a clamping capacitor.		<p>1 V<sub>p-p</sub> (with sync) DC: 1.8 V</p>
6	D-VDD	Power supply pin for DDS/BUS/V-CD/H-CD sections.	—	DC 5 V
7	COMB C-IN /FORCED-S	<p>Input chroma signal from Comb filter through a clamping capacitor. When this pin is connected to V<sub>CC</sub>, color killer is OFF and SECAM ID is ON forcibly. (forced SECAM mode)</p> <p>Refer to FUNCTION DESCRIPTION.</p>		<p>0.3 V<sub>p-p</sub> (burst) DC: 2.4 V</p> <p>4.0 V ≤ Forced-S ≤ 5.0 V (Th: 3.5 V)</p>
8	D-GND	GND pin for DDS/BUS/V-CD/H-CD sections.	—	
9	HS	<p>Output pin of horizontal synchronizing signal.</p> <p>Minimum pull-down resistor is 2.7 kΩ.</p>		<p>3.8 V ≤ Hi ≤ 4.6 V 0 ≤ Low ≤ 1.0 V</p>
10	SCP	<p>Sand Castle Pulse output pin.</p> <p>The clamping pulse and the horizontal blanking pulse are outputted.</p>		<p>3.6 V ≤ CP ≤ 4.4 V 1.6 V ≤ H-BLK ≤ 2.4 V 0.0 V ≤ Low ≤ 0.8 V</p> <p>with pull-down resistor (7.5 kΩ)</p>

Pin No.	Pin Name	Function	Interface Circuit	Input/Output Signals
11	Yvi-OUT	Output pin to synchronize inputs. Y signal from video-SW is outputted.		<p>1 V<sub>p-p</sub> (with sync) DC: 2.1 V</p>
12	SYNC-V <sub>CC</sub>	Power supply pin for liner SYNC/HVCO sections.	—	DC 5 V
13	SCL	SCL pin for I <sup>2</sup> C BUS.		
14	SDA	SDA pin for I <sup>2</sup> C BUS.		
15	YS3 (RGB1-in)	Pin to switch main signals and RGB1 signals. If the voltage of this pin is HI and the RGB1-ENB data is "enable" via I <sup>2</sup> C BUS, RGB1-IN is selected.  And its status is responded to the Read Bus data.		<p>1.0 V ≤ RGB1 ≤ 5.0 V (Th: 0.7 V)</p>
16	SYNC-GND	GND pin for liner SYNC/HVCO sections.	—	

Pin No.	Pin Name	Function	Interface Circuit	Input/Output Signals
17	Cr1-IN	Input Y1/Cb1/Cr1 signal through a clamping capacitor. (selected by I <sup>2</sup> C BUS.)  When Y/Cb/Cr1-IN is active, Y1 signal is synchronized.		Y: 1 V <sub>p-p</sub> (with sync) DC: 1.7 V
18	Cb1-IN			
19	Y1-IN			Cb/Cr: 0.7 V <sub>p-p</sub> (100% color bar) DC: 2.5 V
20	CLP-FIL	Connect a filter for clamping Y signal.		

Pin No.	Pin Name	Function	Interface Circuit	Input/Output Signals
21	Y-OUT	Y/Cb/Cr output pins. The output's amplitudes is variable from 0.5 to 1.6 V <sub>p-p</sub> by I <sup>2</sup> C BUS.		DC; Y: 1.3 V, Cb/Cr: 1.8 V  AC; Y: 0.7 V <sub>p-p</sub> (0 dB, non-sync) Cb/Cr: 0.7 V <sub>p-p</sub> (0 dB)
22	Cb-OUT			
23	Cr-OUT			
24	YS1 (YCbCr2-in)	Pin to switch main signals and YCbCr2 signals.		$1.0\text{ V} \leq \text{YCbCr2} \leq 5.0\text{ V}$ (Th: 0.7 V)
25	B1-IN	Input RGB1 signal through a clamping capacitor. (selected by YS3 and I <sup>2</sup> C BUS.)		0.7 V <sub>p-p</sub> DC: 2.5 V
26	G1-IN			
27	R1-IN			
28	Y/C-GND	GND pin for Y/C/Text/Video-SW/ 1 H DL sections.	—	



Pin No.	Pin Name	Function	Interface Circuit	Input/Output Signals
29	Cr2-IN	Input Y2/Cb2/Cr2 signal through a clamping capacitor. (selected by YS1.)		Y: 1 V <sub>p-p</sub> (with sync) DC: 1.7 V  Cb/Cr: 0.7 V <sub>p-p</sub> (100% color bar) DC: 2.5 V
30	Cb2-IN			
31	Y2-IN			
32	Y/C-V <sub>CC</sub>	Power supply pin for Y/C/Text/Video-SW/1HDL sections.	—	DC 5 V
33	B2-IN	Input RGB2 signal through a clamping capacitor. (selected by YS2.)		0.7 V <sub>p-p</sub> DC: 2.5 V
34	G2-IN			
35	R2-IN			
36	YS2/YM (RGB2-in)	Pin to switch main signals and RGB2 inputs. Half-tone ON/OFF SW is also included. Half tone gain is selected by I <sup>2</sup> C BUS.		1.0 V ≤ YM ≤ 1.5 V 2.5 V ≤ RGB2 ≤ 5.0 V (Th1: 0.7 V, Th2: 2.0 V)

Pin No.	Pin Name	Function	Interface Circuit	Input/Output Signals
37	FIL	Connect this terminal to Y/C V <sub>CC</sub> .	—	—
38	X'TAL	Pin to connect a 16.2 MHz crystal.  Recommended crystal: NR-18 NT162020A, made by NIHON DENPA KOGYO CO, LTD.		16.2 MHz wave
39	C3-IN	Input C3 signal through a clamping capacitor.		0.3 V <sub>p-p</sub> (burst) DC: 1.6 V
40	APC-FIL	Connect APC filer.		
41	CVBS3/Y3-IN	Input CVBS3/Y3 signal through a clamping capacitor.		CVBS: 1 V <sub>p-p</sub> Y: 1 V <sub>p-p</sub> (with sync) DC: 1.8 V

Pin No.	Pin Name	Function	Interface Circuit	Input/Output Signals															
42	ADDRESS	<p>Slave address setting pin. Select slave address. When this pin is open, 8A/8B<sub>H</sub> is selected.</p> <table border="1"> <tr> <td>W</td> <td>88<sub>H</sub></td> <td>8A<sub>H</sub></td> <td>8E<sub>H</sub></td> </tr> <tr> <td>R</td> <td>89<sub>H</sub></td> <td>8B<sub>H</sub></td> <td>8F<sub>H</sub></td> </tr> </table>	W	88 <sub>H</sub>	8A <sub>H</sub>	8E <sub>H</sub>	R	89 <sub>H</sub>	8B <sub>H</sub>	8F <sub>H</sub>		<p><math>88/89_H \leq 1.3 V</math>  <math>3.9 V \leq 8E/8F_H</math>                      (Th1: 1.5 V, Th2: 3.2 V)</p>							
W	88 <sub>H</sub>	8A <sub>H</sub>	8E <sub>H</sub>																
R	89 <sub>H</sub>	8B <sub>H</sub>	8F <sub>H</sub>																
43	C2-IN	Input C2 signal through a clamping capacitor.		<p>0.3 V<sub>p-p</sub> (burst)                      DC: 1.6 V</p>															
44	CVBS2/Y2-IN	Input CVBS2/Y2 signal through a clamping capacitor.		<p>CVBS: 1 V<sub>p-p</sub>                      Y: 1 V<sub>p-p</sub> (with sync)                      DC: 1.8 V</p>															
45	COMB SYS	<p>The status of color system is responded to pin 45 and pin 46. It is the same as Read BUS status.</p> <table border="1"> <thead> <tr> <th>Color System</th> <th>Pin 45</th> <th>Pin 46</th> </tr> </thead> <tbody> <tr> <td>M-PAL</td> <td>Low</td> <td>Low</td> </tr> <tr> <td>4.43PAL, SECAM, B/W</td> <td>High</td> <td>Low</td> </tr> <tr> <td>3.58/4.43 NTSC</td> <td>Low</td> <td>High</td> </tr> <tr> <td>N-PAL</td> <td>High</td> <td>High</td> </tr> </tbody> </table> <p>Refer to FUNCTION DESCRIPTION.</p>	Color System	Pin 45	Pin 46	M-PAL	Low	Low	4.43PAL, SECAM, B/W	High	Low	3.58/4.43 NTSC	Low	High	N-PAL	High	High		<p>5 V High                      0 V Low</p>
Color System	Pin 45	Pin 46																	
M-PAL	Low	Low																	
4.43PAL, SECAM, B/W	High	Low																	
3.58/4.43 NTSC	Low	High																	
N-PAL	High	High																	

Pin No.	Pin Name	Function	Interface Circuit	Input/Output Signals
46	Fsc-OUT	Sub-carrier output pin. Refer to FUNCTION DESCRIPTION.		AC: 0.84 V <sub>p-p</sub> DC: as blow figure. 
47	AFC-FIL	Connect AFC filter.		
48	C1-IN	Input C1 signal through a clamping capacitor.		0.3 V <sub>p-p</sub> (burst) DC: 1.6 V

## Write Mode

Slave Address: 88H/8AH/8EH

Sub Address	MSB D7	D6	D5	D4	D3	D2	D1	LSB D0	Preset	
80	P/N ID	P/N GW			TINT					0010 0000
81		SUB-CONTRAST			SUB-COLOR					1000 1000
82		SHARPNESS GAIN			SHARPNESS EQ		SHARPNESS f <sub>0</sub>			1000 0000
83	BS POINT				Y-OUT LEVEL					0010 0000
84	DC REST				C-OUT LEVEL					0010 0000
85	LPF	S-D TRAP	C-TRAP SW	FILTER SW	BPF Q	BPF Q	BPF f <sub>0</sub>		0000 0000	
86	N-COMB		Y-DL		COLOR SYSTEM					0010 1000
87	Cb/Cr-MUTE	HALF TONE	RGB SELECT		VIDEO SELECT					0000 0000
88		Cb OFFSET1			Cr OFFSET1					1000 1000
89		Cb OFFSET2			Cr OFFSET2					1000 1000
8A	MVM	AFC GAIN		V C/D MODE	V-FREQ					0000 0000
8B		S B-Y ADJ			S R-Y ADJ					1000 1000
8C	S-INHBT	S ID	S GP		S V-ID	BELL f <sub>0</sub>	BELL/HPF		0000 0000	
8D	0	0	0	0	HS-PH	0	SETUP-SW	RGB1 ENB	1000 0000	
8E	0	0	0	0	0	0	0	0	0000 0000	
8F		TEST MODE								0000 0000

## Read Mode

Slave Address: 89H/8BH/8FH

Sub Address	MSB D7	D6	D5	D4	D3	D2	D1	LSB D0
00	POR	COLOR SYSTEM		X-TAL		N-DET		H-LOCK
01	V-FREQ	V-STD	C ID	V-SIG	V15	(note1)	(note1)	0

Note1: Don't care

## Bus Control Function

### Write Mode

Slave Address: 88<sub>H</sub>/8A<sub>H</sub>/8E<sub>H</sub>

Item/Number of Bits	Function	Variable Range	Preset
TINT/⑥	TINT adjustment for NTSC	00H: -33 deg to 3F H: +33 deg (1LSB = 1.1 deg)	0 deg
P/N GW/①	PAL/NTSC gate width	0: 2.0 μs, 1: 3.2 μs	2.0 μs
P/N ID/①	PAL/NTSC sensitivity SW	0: Normal, 1: Low	Normal
SUB-COLOR/④	Sub-color control	0 H: -2 dB to F H: 2 dB	0 dB
SUB-CONTRAST/④	Sub-contrast control	0 H: -2 dB to F H: 2 dB	0 dB
SHARPNESS f <sub>0</sub> /②	Sharpness center frequency changing	00: 2.5 MHz, 01: 3.2 MHz 10: 4.0 MHz, 11: OFF	2.5 MHz
SHARPNESS EQ/②	Sharpness equalizer characteristic (evaluation with 2T-pulse)	00: 1: 1.2, 01: 1: 1 10: 1.2: 1, 11: 1.4: 1	1: 1.2
SHARPNESS GAIN/④	Sharpness gain control	0 H: -6 dB to F H: 6 dB	0 dB
Y-OUT LEVEL/⑥	Y output level control (pin 21)	00 H: 0.5 to 3 F H: 1.6 V <sub>p-p</sub>	1.05 V <sub>p-p</sub>
BS POINT/②	Black Stretch start point changing	00: OFF (by-pass), 01: 20 IRE 10: 30 IRE, 11: 40 IRE	OFF
C-OUT LEVEL/⑥	Cb/Cr output level control (pin 22/23)	00 H: 0.5 to 3 F H: 1.6 V <sub>p-p</sub>	1.05 V <sub>p-p</sub>
DC REST/②	DC restoration ratio adjustment	00: 100%, 01: 95% 10: 90%, 11: 85%	100%
BPF f <sub>0</sub> /②	BPF/TOF f <sub>0</sub> adjustment	00: -400 kHz, 01: +0 kHz, 10: +400 kHz, 11: OFF (by-pass)	-400 kHz
BPF Q/②	BPF/TOF Q adjustment	00: 1.0, 01: 1.5 10: 2.0, 11: 2.5	1.0
FILTER SW/①	BPF/TOF switch	0: BPF, 1: TOF	BPF
C-TRAP SW/①	Chroma trap switch	0: ON, 1: OFF	ON
S-D TRAP/①	SECAM double trap switch	0: OFF, 1: ON	OFF
LPF/①	Y/Cb/Cr LPF switch	0: ON, 1: OFF (by-pass)	ON
COLOR SYSTEM/③	Color system switching Europe automatic mode; 4.43PAL, 4.43NTSC, 3.58NTSC, SECAM South America automatic mode; 3.58NTSC, M-PAL, N-PAL Refer to FUNCTION DESCRIPTION.	000: Europe automatic 001: South America automatic 010: 3.58 NTSC 011: 4.43 NTSC 100: 4.43 PAL 101: SECAM 110: M-PAL, 111: N-PAL	Europe automatic
Y-DL/④	Y-DL time adjustment (1LSB = 40 ns) Refer to FUNCTION DESCRIPTION.	0000: 120 to 1010: 520 ns 1011 to 1111: don't use	320 ns
N-COMB/①	1 H addition switch, when NTCS.	0: OFF, 1: ADD	OFF
VIDEO SELECT/④	Selection of input video signals	Refer to FUNCTION DESCRIPTION.	0000
RGB SELECT/②	Selection of input sources. Refer to FUNCTION DESCRIPTION.	00: Main, 01: YCbCr1 10: RGB1, 11: don't use	Main
HALF TONE/①	Half tone gain switch	0: -10 dB, 1: -6 dB	-10 dB

Item/Number of Bits	Function	Variable Range	Preset
Cb/Cr-MUTE/①	Cb/Cr output mute switch	0: OFF, 1: ON	OFF
Cb/Cr OFFSET1/④/④	Cb/Cr offset adjustment (main route)	0 H: -12 to F H: +10.5 mV	0 mV
Cb/Cr OFFSET2/④/④	Cb/Cr offset adjustment (YCbCr2 input)	0 H: -12 to F H: +10.5 mV	0 mV
V-FREQ/③	V count down frequency switch.  Automatic mode 1; 50/60 Hz automatic distinction. At no-signal, the last statement is kept. Right after power-on, 50 Hz mode is run.  Automatic mode 2; 50/60 Hz automatic distinction. And 50 Hz mode is run at no-signal.  Refer to FUNCTION DESCRIPTION.	000: Automatic mode 1, 001: 50 Hz, 010: 60 Hz, 011: Automatic mode 2, 100: Forced 312.5 H (AFC free-run), 101: Forced 262.5 H (AFC free-run), 110: Forced 313 H (AFC free-run), 111: Forced 263 H (AFC free-run)	Automatic mode 1
V C/D MODE/②	V count down judge switch.  Refer to FUNCTION DESCRIPTION.	00: Normal, 01: Teletext, 10: Fast, 11: Normal	Normal
AFC GAIN/②	AFC sensitivity switch	00: +6 dB, 01: 0 dB, 10: -6 dB, 11: -17 dB	+6 dB (data: 00)
MVM/①	Macrovision Mask + AFC Mask	0: Narrow, 1: Always masked	Narrow
S R-Y ADJ/④	SECAM R-Y black adjustment	0 H: -10 to F H: 8.8 mV	0 mV
S B-Y ADJ/④	SECAM B-Y black adjustment	0 H: -10 to F H: 8.8 mV	0 mV
BELL/HPF/②	SECAM bell/HPF switching. Or the high frequency side on SECAM bell filter is boosted.  Refer to FUNCTION DESCRIPTION.	00: Bell, 01: Boost 1, 10: Boost 2, 11: HPF	Bell
BELL f <sub>0</sub> /①	BELL f <sub>0</sub> adjustment	0: Normal, 1: +15 kHz	Normal
S V-ID SW/①	SECAM V-ID switch	0: OFF, 1: ON	OFF
S GP/②	SECAM gate position adjustment (its width is same)	00: Normal, 01: 0.4 μs delay, 10: Normal, 11: 0.4 μs forward	Normal
S ID/①	SECAM sensitivity switch	0: Normal, 1: Low	Normal
S-INHBT/①	SECAM inhibition switch	0: Normal, 1: Inhibited	Normal
RGB1 ENB/①	Enable YS3 to switch to RGB1-IN.  Refer to FUNCTION DESCRIPTION.	0: Disable, 1: Enable	Disable
SETUP-SW/①	Y black level set-up	0: Normal, 1: Set-up	Normal
HS-PH/①	HS Output phase switch	0: H-Sync (4.7 μs), 1: GP (3.2 μs)	H-Sync
TEST MODE/⑧	Factory test mode. Set all zero.	—	00H

## Read Mode

Slave Address: 89<sub>H</sub>/8B<sub>H</sub>/8F<sub>H</sub>

Item/Number of Bits	Function	Variable Range
H-LOCK/①	H.Lock detection	0: Un-lock, 1: Lock
N-DET/②	Noise judgment	00: SN > 30 dB, 01: —, 10: 30 dB > SN > 20 dB, 11: 20 dB > SN
X'TAL/②	Crystal mode judgment	00: 4.433619 MHz (PAL) 01: 3.579545 MHz (NTSC) 10: 3.575611 MHz (M-PAL) 11: 3.582056 MHz (N-PAL)
COLOR SYSTEM/②	Color system judgment	00: B/W, 01: PAL 10: NTSC, 11: SECAM
POR/①	Power On Reset	0: Normal, 1: Resistor preset
V15/①	Status of pin 15 voltage Refer to FUNCTION DESCRIPTION.	0: Low, 1: High
V-SIG/①	Internal V.pulse detection for V.lock	0: Existing, 1: Not existing
C ID/①	Input signal condition (detection of burst signal on C-IN pins) Refer to FUNCTION DESCRIPTION.	0: Not detected (CVBS), 1: Detected (Y/C)
V-STD/①	Decision on the standard of the vertical frequency. When no-signal, 1: STD is responded.	0: Non-STD, 1: STD
V-FREQ/①	Vertical frequency judgment. Right after power-on, 0: 50 Hz is responded. At no-signal, the last statement is kept.	0: 50 Hz, 1: 60 Hz



**Function Description**

**Video Select, Auto-SW**

- (1) "AUTO-SW" = (1) Manual Select

In video SW section, input signal is selected by the BUS as Figure 1 and Table 1. Mainly, CVBS-OUT (pin 3) is used for the comb filter input, and Yvi-OUT (pin 11) is used for synchronization (pin 2). Besides, on chroma line from video SW to main route, the peak detection is done during the burst period. The result is responded to the Read BUS data, C ID.

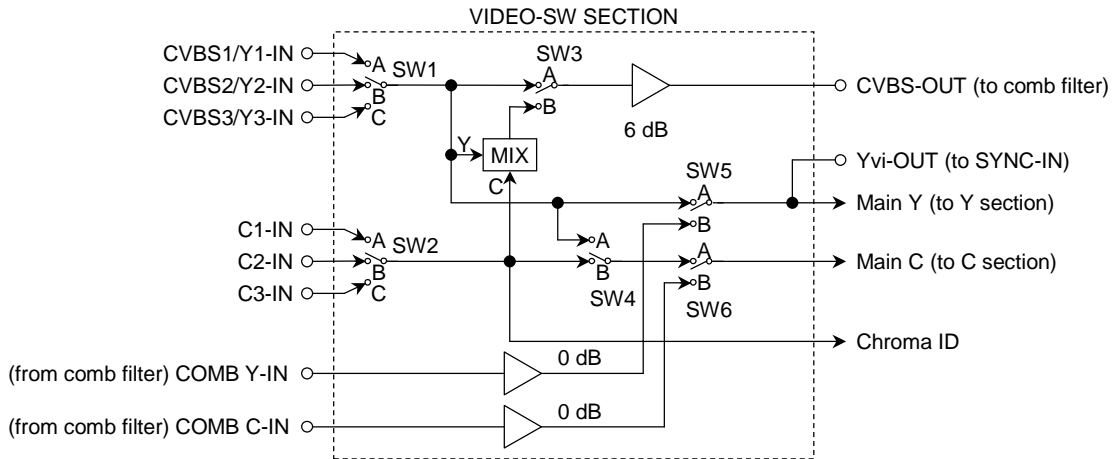

**Figure 1 Signal Route at Video SW Section**

**Table 1 Selected Input and Pin 3/11 Output from Video SW Section**

Bus Data	SW Mode						To Y/C Section		Output from V-SW	
	1	2	3	4	5	6	Main Y	Main C	CVBS-Out	Yvi-Out
0000	A		A	A	A	A	CVBS1	CVBS1	CVBS1	CVBS1
0001	B		A	A	A	A	CVBS2	CVBS2	CVBS2	CVBS2
0010	C		A	A	A	A	CVBS3	CVBS3	CVBS3	CVBS3
0100	A	A	B	B	A	A	Y1	C1	Y1 + C1	Y1
0101	B	B	B	B	A	A	Y2	C2	Y2 + C2	Y2
0110	C	C	B	B	A	A	Y3	C3	Y3 + C3	Y3
1000	A		A		B	B	COMB Y	COMB C	CVBS1	COMB Y
1001	B		A		B	B	COMB Y	COMB C	CVBS2	COMB Y
1010	C		A		B	B	COMB Y	COMB C	CVBS3	COMB Y
others	—	—	—	—	—	—	Don't use.			

**External Input SWs**

External inputs are selected by the BUS data and fast SWs. Final outputs from pin 21/22/23 are shown in Table 2. RGB1-IN interface complies with SCART connector. Therefore it is active, when RGB1-IN is enable by the BUS data and when YS3 (pin 15) is also high. The status of YS3 (pin 15) is responded to the Read BUS data, V15.

**Table 2 Outputs from Pin 21/22/23**

RGB Select	RGB1 ENB	YS3 (RGB1)	YS1 (YCbCr2)	YS2 (RGB2)	Output		
00	0	L	L	L	Main (from V-SW)		
		H					
	1	L			RGB1		
		H					
01	0	L			L	L	YCbCr1
		H					
	1	L					RGB1
		H					
10	0	L	L	L	RGB1		
		H					
	1	L					
		H					
11	—	—			—	—	
—	—	—			H	—	YCbCr2
—	—	—			L	H	RGB2
—	—	—			H		

Note2: RGB SELECT/RGB1 ENB: I<sup>2</sup>C BUS data, YS1/2/3: Fast SW

**Color System**

Distinguishable color systems are selected by the write BUS data, COLOR SYSTEM. The demodulated color system is responded to the read BUS data, COLOR SYSTEM and XTAL. (refer to BUS CONTROL FUNCTION) The system data is also responded to Comb SYS (pin 45) and fsc-OUT (pin 46) as Table 3. If distinguishable color system signal is not received, the system data is responded with B/W.

Besides, if pin 7 is connected to VCC (more than 3.5 V), Forced SECAM mode is active. In this mode, SECAM system is identified forcibly. It has priority over the BUS selection.

**Table 3 DC Level of Pin 45 and 46 on Each Color System**

Color System	Pin 45	Pin 46
M-PAL	Low	Low
4.43PAL, SECAM, B/W	High	Low
3.58/4.43NTSC	Low	High
N-PAL	High	High

**Secam Bell Filter**

SECAM bell filter characteristics can be changed by the BUS data, BELL/HPF. The group delay near chroma band is corrected by changing filter characteristic. As a result, S/N looks better. Besides, center frequency  $f_0$  of bell is changed by BELL  $f_0$ . Indirectly, it is changed by BPF (TOF)  $f_0$ .

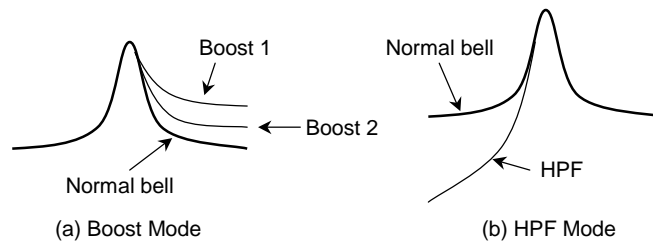
**Figure 2 SECAM Bell Filter Characteristics**

**Vertical Count-Down**

In Automatic of V C/D MODE, the vertical synchronization is controlled by internal PLL. In Fast mode, it is synchronized with the inputted synchronizing signal and the pull-in time is short. Furthermore the time is shorter in Very fast mode by the expanded pull-in range. Pull-in range of vertical count-down is determined by the BUS data, V C/D MODE and V-FREQ as Table 4.

**Table 4 V C/D Pull-In Range**

V C/D Mode		Normal	Teletext	Fast
		00, 11	01	10
000	Automatic 1	224-353 H	224-353 H	32-353 H
001	50 Hz	274-353 H	274-353 H	32-353 H
010	60 Hz	224-297 H	224-297 H	32-297 H
011	Automatic 2	224-353 H	224-353 H	32-353 H
100	312.5 H	Forced 312.5 H mode&AFC free-run		
101	262.5 H	Forced 262.5 H mode&AFC free-run		
110	313 H	Forced 313 H mode&AFC free-run		
111	263 H	Forced 263 H mode&AFC free-run		

Note 3: 00, 11; Normal Normal vertical input mode. It is good performance of vertical phase keeping for standard TV signal sync. This mode is recommended in the state of stability. And this mode can detect teletext or VCR skew sync.

Note 4: 01; Teletext This mode is less performance of vertical phase keeping for standard TV signal sync against "Normal". However, pull-in speed is faster few vertical periods than "Normal". Therefore this mode is recommended for tesetext sync. On the other hand, this mode can detect standard TV signal sync in the state of stability but it is less performance of vertical phase keeping in week signal as about -3 dB against "Normal".

Note 5: 10; Fast This mode is same performance of vertical phase keeping for standard TV signal sync of "Teletext". But it is faster pull-in speed faster than "Teletext" because pull-in ranges wider than "Teletext". (refer to Table 5) Therefore, this mode is better to use when channel changing, but is not recommended to use in the state of stability or in week signal due to too wide pull-in range and incorrect actions of vertical keeping appearing.

**Y-DL Adjustment**

Table 5 shows Y output delays against Y input on condition with BPF = f<sub>0</sub>, Q = 2.0, Y-DL = Min and LPF = ON. Y-out signal can be delayed by the BUS data, Y-DL. The adjustment time of one step is 40 ns.

**Table 5 Y Ddelays According to the Color System**

Color System	Y Delay (ns)
PAL	420
NTSC	460
SECAM	645

**Pulses Timing**

**Horizontal Period (typical output phase of horizontal pulses)**

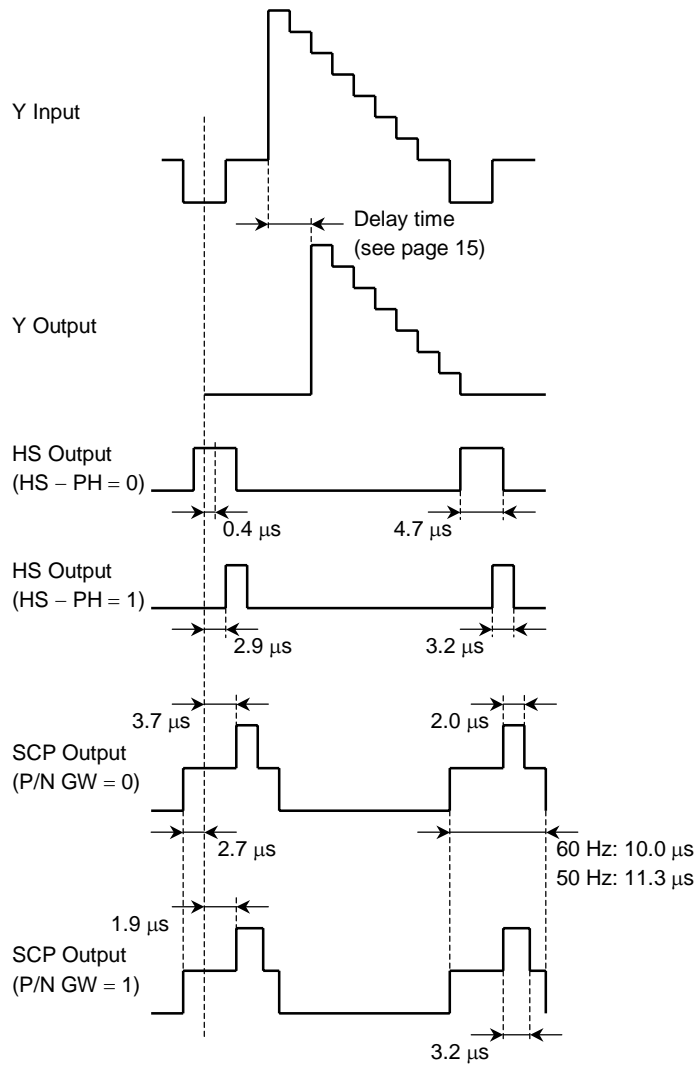

**Vertical Period (typical output phase of vertical pulse)**

**60 Hz ODD**

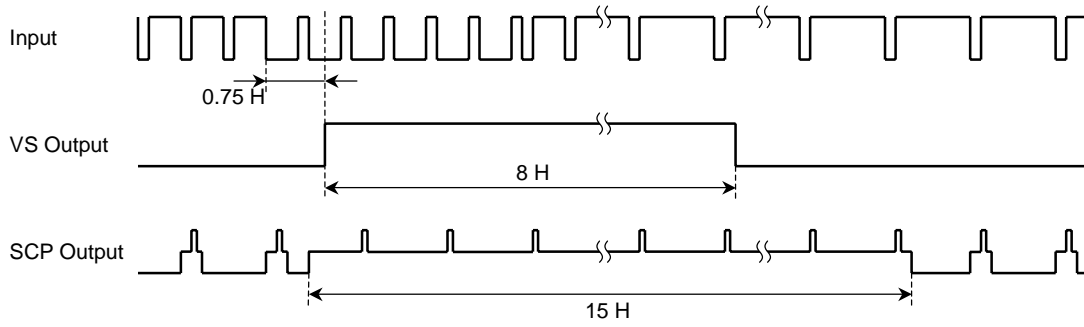

**60 Hz EVEN**

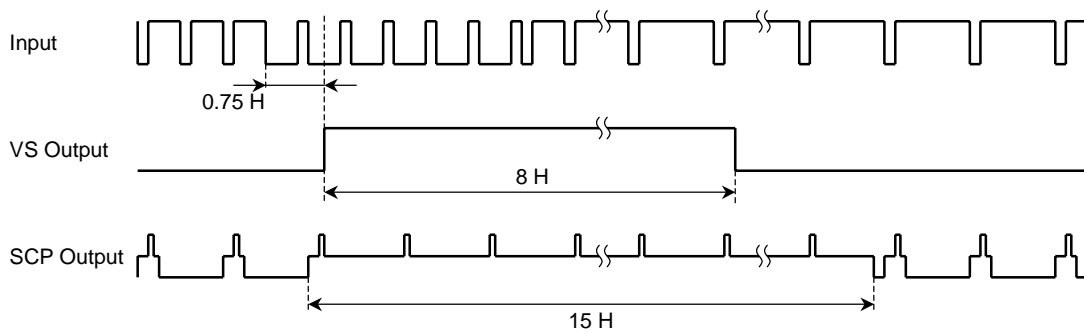

**50 Hz ODD**

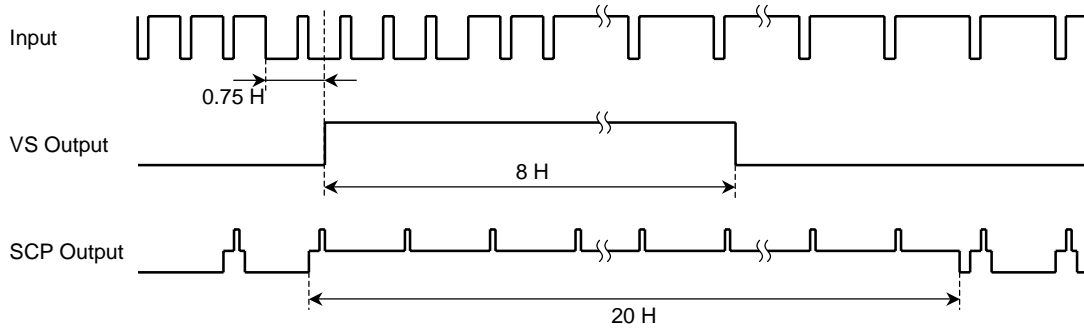

**50 Hz EVEN**

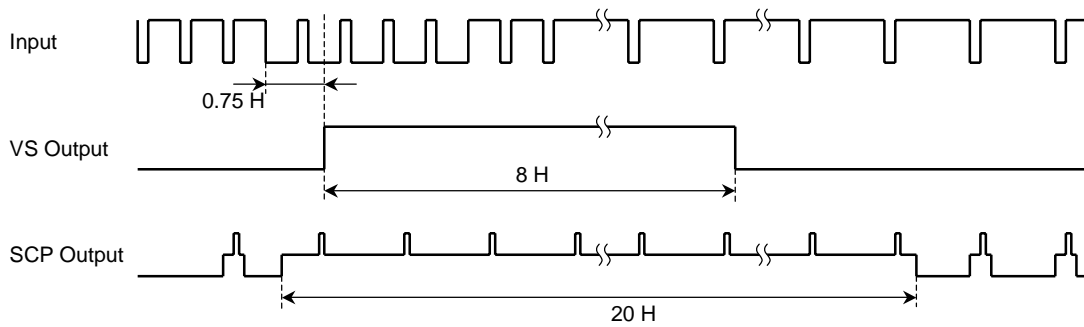

**Maximum Ratings (Ta = 25°C)**

Characteristics	Symbol	Rating	Unit
Supply voltage	V <sub>CC/DDmax</sub>	5.5	V
Signal voltage at each input pin	e <sub>inmax</sub>	5	V <sub>p-p</sub>
Power consumption	P <sub>D</sub> (Note6)	1644	mW
Power consumption reduction ratio	1/θ <sub>ja</sub>	13.16	mW/°C
Operating temperature	T <sub>opr</sub>	-25 to 65	°C
Storage temperature	T <sub>stg</sub>	-55 to 150	°C

Note 6: Put on the circuit board. Refer to the figure below.

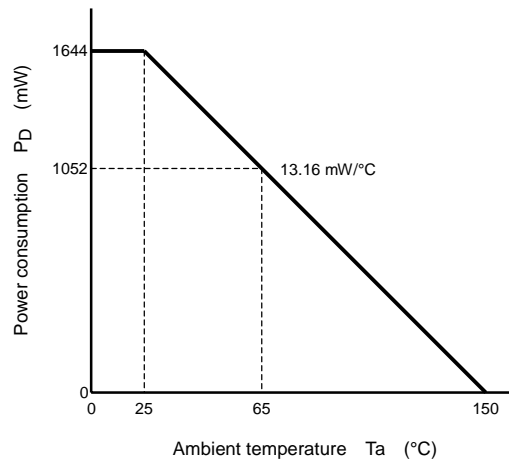

**Figure 3 Power Consumption Reduction Against Ambient Temperature**

**Supply Voltage**

Characteristics	Description	Min	Typ.	Max	Unit
Supply voltage	Pin 6, 12, 32	4.75	5.0	5.25	V

**Electrical Characteristics**

(Y/C – V<sub>CC</sub>/SYNC – V<sub>CC</sub>/D – V<sub>DD</sub> = 5 V and Ta = 25°C, unless otherwise specified)

**Current Consumption**

Pin No.	Pin Name	Symbol	Min	Typ.	Max	Unit
6	D V <sub>DD</sub>	I <sub>DD</sub>	4	7	15	mA
12	SYNC V <sub>CC</sub>	I <sub>CC1</sub>	9	13.5	20	
32	Y/C V <sub>CC</sub>	I <sub>CC2</sub>	75	100	130	

Application Circuit

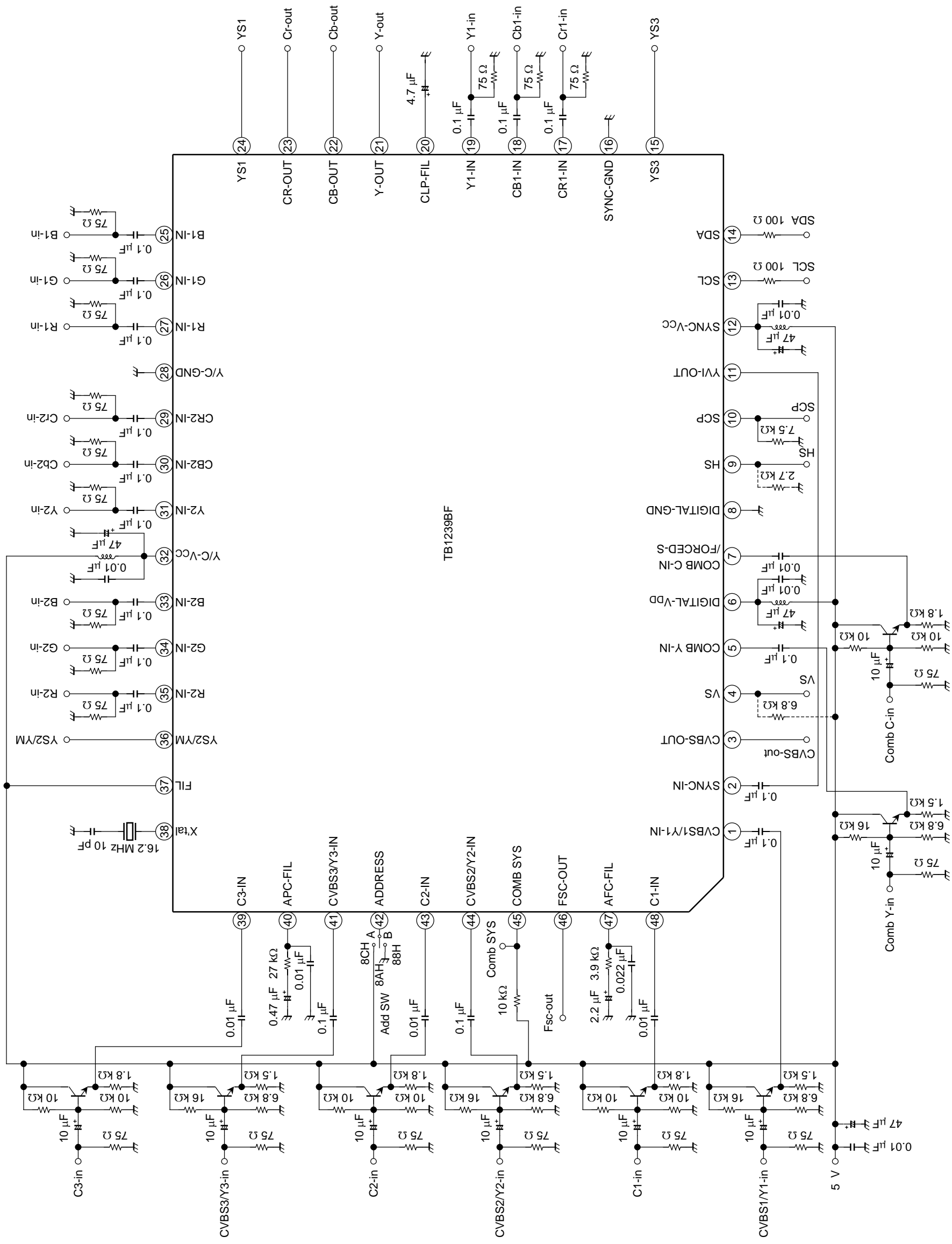



**Package Dimensions**

QFP48-P-1014-0.80

Unit : mm

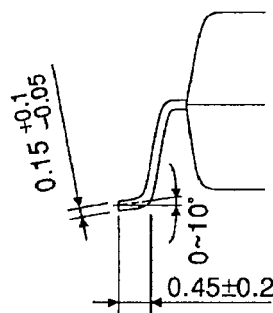
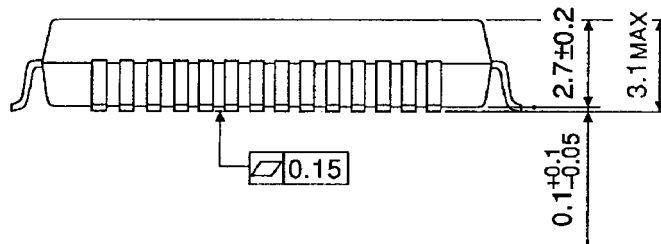
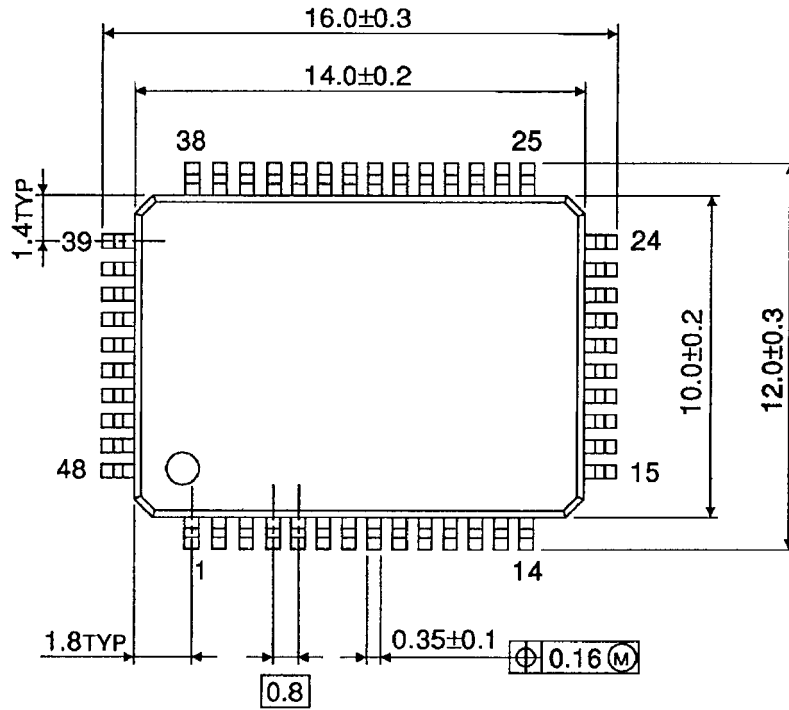

Weight: 0.83 g (typ.)

**RESTRICTIONS ON PRODUCT USE**

000707EBA

- TOSHIBA is continually working to improve the quality and reliability of its products. Nevertheless, semiconductor devices in general can malfunction or fail due to their inherent electrical sensitivity and vulnerability to physical stress. It is the responsibility of the buyer, when utilizing TOSHIBA products, to comply with the standards of safety in making a safe design for the entire system, and to avoid situations in which a malfunction or failure of such TOSHIBA products could cause loss of human life, bodily injury or damage to property.  
In developing your designs, please ensure that TOSHIBA products are used within specified operating ranges as set forth in the most recent TOSHIBA products specifications. Also, please keep in mind the precautions and conditions set forth in the "Handling Guide for Semiconductor Devices," or "TOSHIBA Semiconductor Reliability Handbook" etc..
- The TOSHIBA products listed in this document are intended for usage in general electronics applications (computer, personal equipment, office equipment, measuring equipment, industrial robotics, domestic appliances, etc.). These TOSHIBA products are neither intended nor warranted for usage in equipment that requires extraordinarily high quality and/or reliability or a malfunction or failure of which may cause loss of human life or bodily injury ("Unintended Usage"). Unintended Usage include atomic energy control instruments, airplane or spaceship instruments, transportation instruments, traffic signal instruments, combustion control instruments, medical instruments, all types of safety devices, etc.. Unintended Usage of TOSHIBA products listed in this document shall be made at the customer's own risk.
- The products described in this document are subject to the foreign exchange and foreign trade laws.
- The information contained herein is presented only as a guide for the applications of our products. No responsibility is assumed by TOSHIBA CORPORATION for any infringements of intellectual property or other rights of the third parties which may result from its use. No license is granted by implication or otherwise under any intellectual property or other rights of TOSHIBA CORPORATION or others.
- The information contained herein is subject to change without notice.