

High Accuracy 4-Channel Low Side LED Driver for CCFL Replacement

FEATURES

- Wide 4.5V to 30V operating range
- 60mA LED current per channel
- 1.5% channel to channel current matching
- Analog Dimming control
- PWM operation up to 5kHz with 10% Duty Cycle
- Low dropout: 150mV @ 20mA
- Built-in Over Temperature Protection
- Lead Free, RoHS Compliant Packaging:
Small 2X3mm DFN

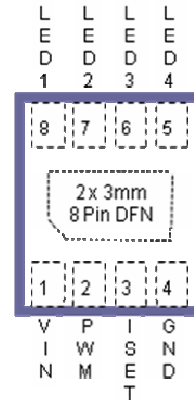

Connect heat sink pad to GND

DESCRIPTION

The SP7616 is a 30V 4-Channel linear low side LED driver. It is capable of powering up to four LED strings of nine LEDs @ 60mA per string for a total of 36 LEDs with 1.5% typical current matching between channels. The desired LED current can be adjusted with an external resistor, and the precision string-to-string current matching ensures consistent color temperature across the whole display. The device also features very low dropout voltage to maximize system efficiency and avoid difficult thermal design constraints. Dimming can be achieved by feeding a PWM signal to the PWM pin, or use an analog signal to control the I_{SET} current, this allows brightness control without unwanted color shifts. Fast LED current turn-on/off time allows up to 5 kHz PWM dimming frequencies with as low as 10% duty cycle, completely eliminating flicker. The built-in thermal protection prevents damage to the device under fault conditions.

TYPICAL APPLICATION CIRCUIT

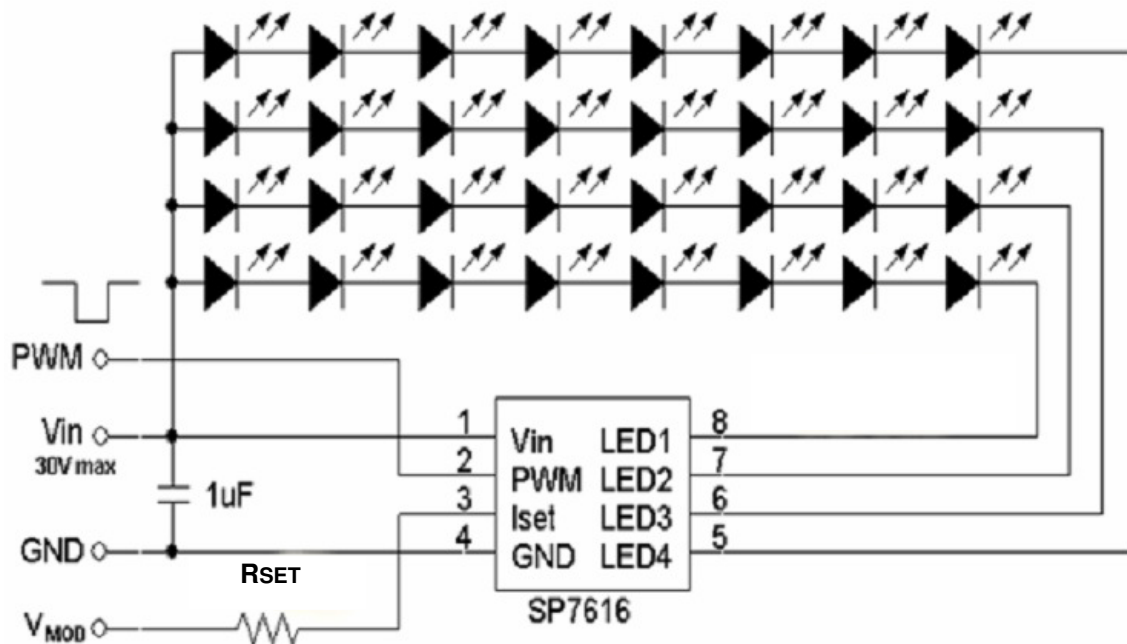

ABSOLUTE MAXIMUM RATINGS

These are stress ratings only and functional operation of the device at these ratings or any other above those indicated in the operation sections of the specifications below is not implied. Exposure to absolute maximum rating conditions for extended period of time may affect reliability.

V _{IN}	-0.3V to 32V
LED1, LED2, LED3, LED4	-0.3V to 32V
I _{SET} , PWM	-0.3V to 6.0V
Storage Temperature.....	-65 °C to 150 °C
Junction Temperature.....	-40°C to +150°C*
Lead Temperature (Soldering, 10 sec).....	300°C

* Internally protected

ELECTRICAL SPECIFICATIONS

Unless otherwise specified: V_{IN} = 4.5V - 30V, C_{IN} = 1μF, -40°C < T_A < 85°C, -40°C < T_J < 125°C. **Bold** values apply over the full operating temperature range.

PARAMETER	MIN	TYP	MAX	UNITS	CONDITIONS
Operating Input Voltage Range	4.5		30	V	
Shutdown Supply Current		30	40	μA	Voltage at I _{SET} is pulled to 3V; V _{IN} 30V
Quiescent Supply Current		350	500	μA	No LED connected, V _{LED} pins are tied to GND. R _{SET} =1MΩ
Quiescent Supply Current		1	1.5	mA	I _{LED} = 30mA
Quiescent Supply Current		1.5	3	mA	I _{LED} = 60mA
LED Current Matching	-3	1.5	3	%	To reference channel (channel 2) -40°C < T _A < 85°C
LED Current Line Regulation		0.5	1	%/V	V _{LED} = 0.5V to 25V, V _{IN} = 28V, R _{SET} = 50kΩ ²
Line Regulation		0.05	0.1	% / V	V _{IN} = 4.5V to 25V, V _{LED} =0.5V ³
Maximum LED Current per channel			60	mA	R _{SET} = 15.38kΩ,
LED Leakage Current			2	μA	PWM pin LOW' V _{LED} 1V; V _{IN} 5V
Dropout Voltage		0.2	0.3	V	Note 4
Output/I _{SET} Current Multiplication Ratio		950			+/- 4 Percent -40°C < T _A < 85°C
Thermal Shutdown Die Temperature		150		°C	I _{LED} = 0mA. LED current will self recover when temperature drops below the trip point, minus thermal shut down hysteresis.
Thermal Shutdown Hysteresis		15		°C	
PWM Pin Logic LOW			0.8	V	Driver is disabled
PWM Pin Logic HIGH	2.4		5.5	V	Driver is active
PWM pin Hysteresis		400		mV	
I _{SET} Voltage	0.985	1.00	1.015		
I _{SET} Shutdown Threshold			3	V	If I _{SET} is pulled above this threshold the device goes into full shutdown
I _{SET} Shutdown Threshold Hysteresis		0.3		V	
PWM Dimming Frequency Range	0.1		5	kHz	Applied to PWM pin
PWM Dimming Duty Cycle Range	10		90	%	Applied to PWM pin
Turn-on time from Shutdown		100	300	μs	V _{MOD} from 5V to 0.0V, R _{SET} = 50kΩ
Turn-off time into Shutdown			20	μs	V _{MOD} from 0.0V to 5V, R _{SET} = 50kΩ

Note

1. Reference channel I_{LED} Variations from specified by R_{SET} value
2. I_{LED} Variations from specified by R_{SET} value at V_{LED} changing from 0.5 to 25V
3. I_{LED} Variations from specified by R_{SET} value at V_{IN} changing from 4.5 to 25V
4. R_{SET} = 31.6kΩ: Dropout voltage is measured as the V_{LED} voltage where LED current drops 5% from nominal value

PIN DESCRIPTION

PIN NAME	DESCRIPTION	PIN #
V _{IN}	Input voltage for the IC. Connect a 1uF decoupling capacitor between this pin and ground.	1
PWM	This pin must be held high to enable the output drivers. It can be used for PWM dimming up to 5 kHz.	2
I _{SET}	Connect resistor R _{SET} from this pin to ground to set output current. Pulling this pin above the shutdown threshold stated in the Electrical Specifications puts the IC into shutdown mode	3
GND	Ground return for LED currents and circuitry of the SP7616	4
LED1-LED4	Connect an LED between each pin and V _{IN} . Current value is controlled by R _{SET} . The current level through each pin is internally matched within 3%. Connect unused channel (s) to GND to save current consumption.	5 - 8

BLOCK DIAGRAM

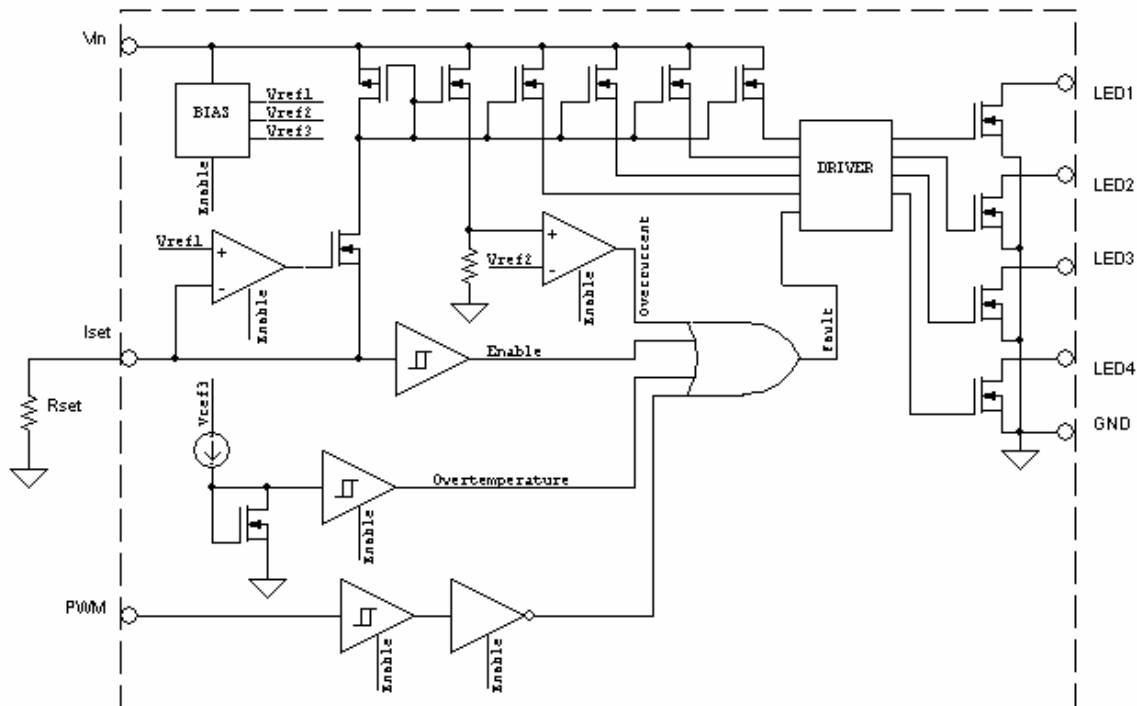

TYPICAL PERFORMANCE CHARACTERISTICS

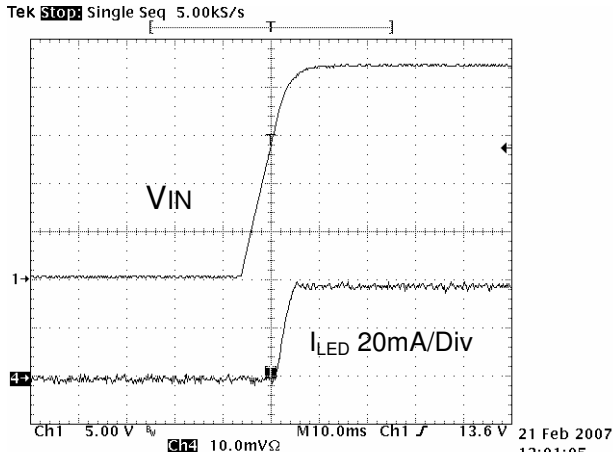

Typical Turn on Characteristics
Channel 1 V_{IN} ; Channel 4 I_{LED}

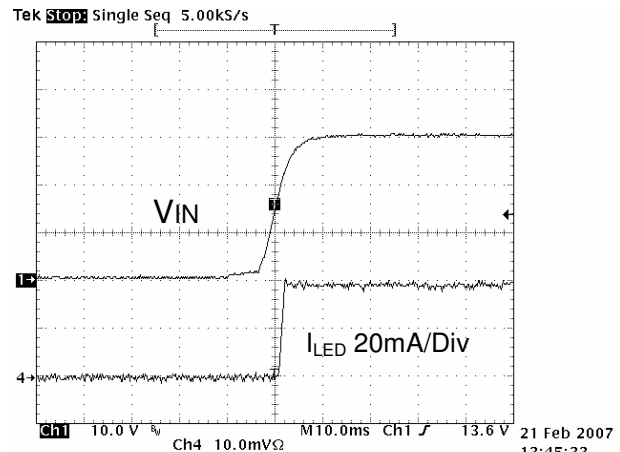

Turn on Maximum V_{IN}
Channel 1 V_{IN} ; Channel 4 I_{LED}

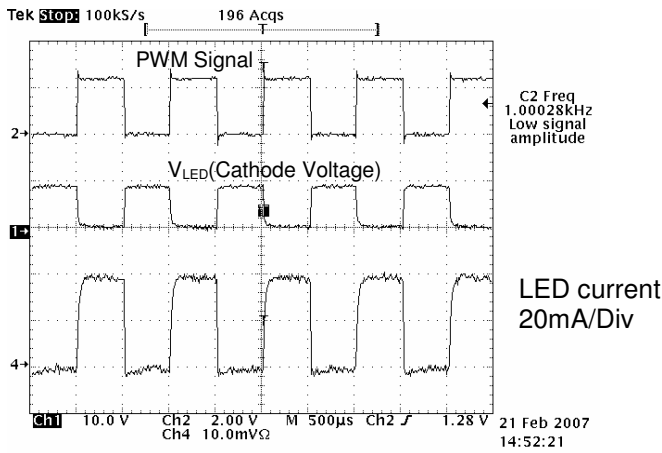

PWM Function 1kHz 50% Duty Cycle

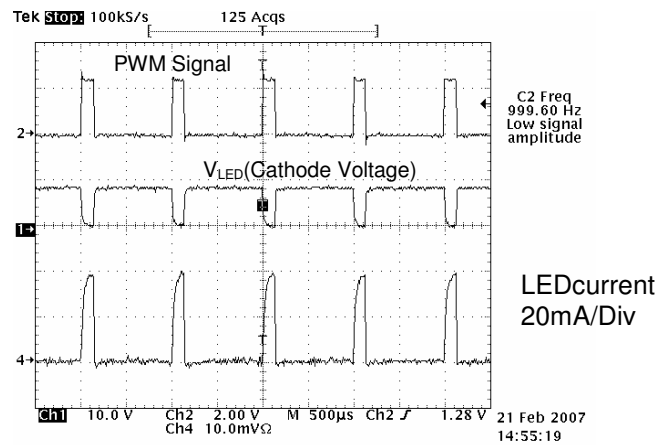

PWM Function 1 kHz 10% Duty Cycle

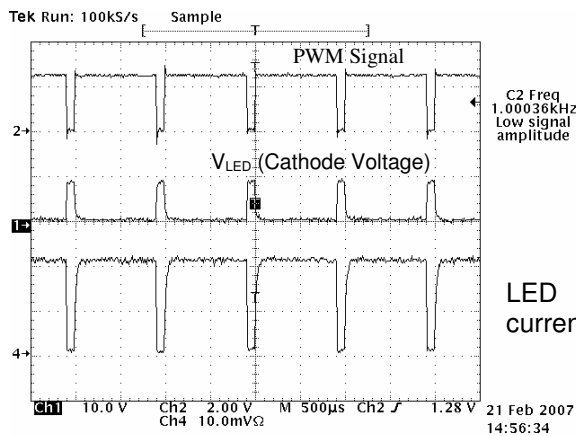

PWM Function 1 kHz 90% Duty Cycle

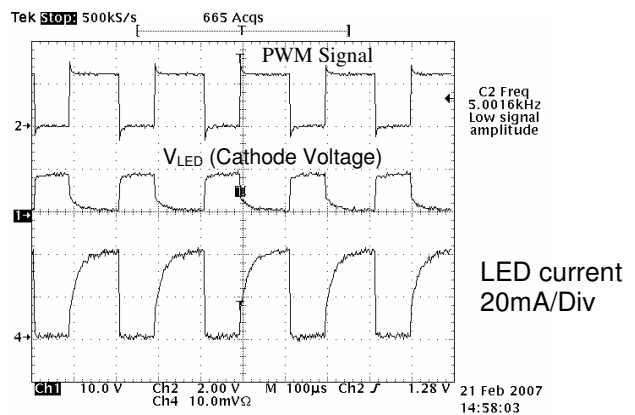

PWM Function 5 kHz 50% Duty Cycle

TYPICAL PERFORMANCE CHARACTERISTICS

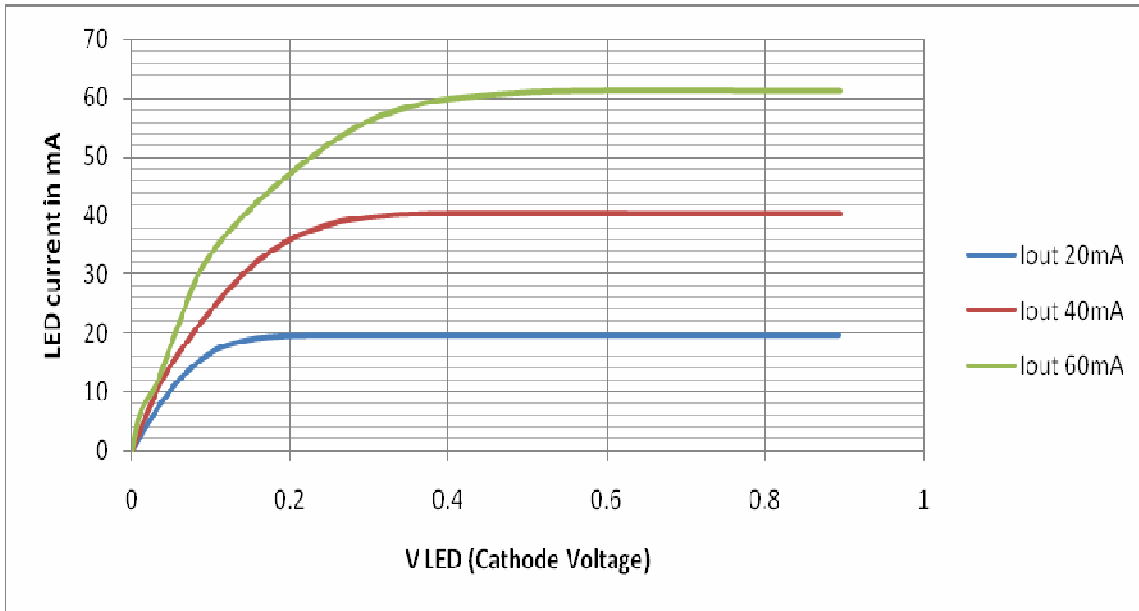

LED Current vs. LED voltage (cathode voltage)
V_{IN} tied to Anode of LED chain

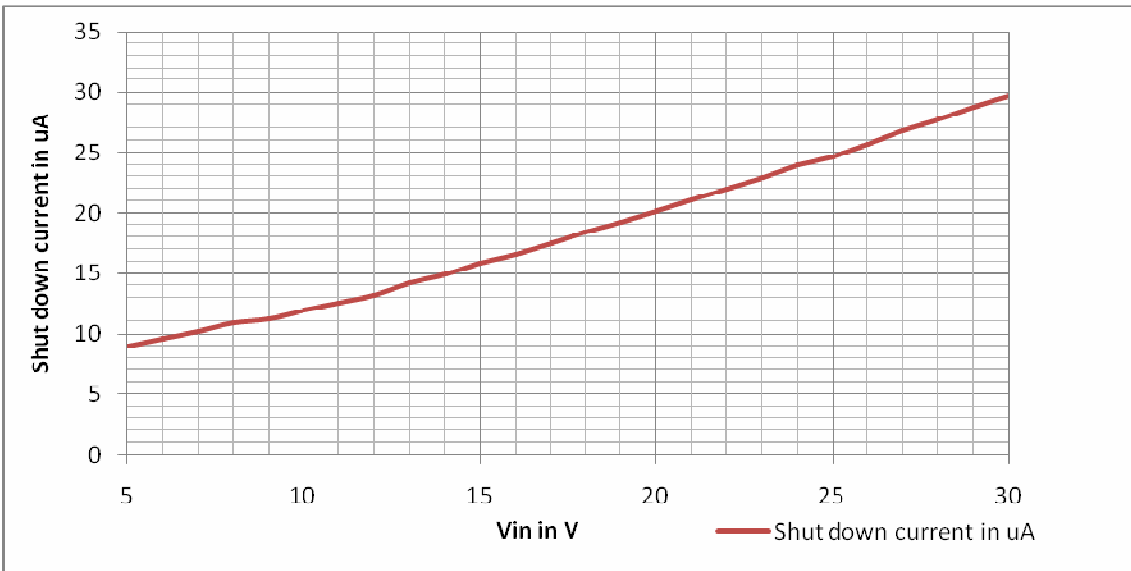

Shutdown current vs. input voltage
Voltage on ISET pin = 3V

Introduction

The SP7616 is a four-channel constant current source LED driver with programmable output current level. The design consists of a regulator reference voltage source, current amplifier, and output driver. The precision reference voltage ensures good performance over voltage and temperature. The four outputs are tightly coupled allowing for excellent LED current matching.

Setting LED current

The LED current is set through the Iset resistor. The SP7616 provides an internal reference voltage that is set to 1V at the Iset Pin (Pin3). R_{SET} is then determined by using equation 1.

$$R_{SET} = V_{ISET} * I_{MULT} / I_{LED} \text{ (k}\Omega\text{)}, \quad (1)$$

Where

V_{ISET} is the internal reference (1V)

I_{MULT} I_{SET} Current Multiplication Ratio

I_{LED} is the desired Led current.

In example 1: For a 20mA LED current, the current set resistor should be

$$R_{SET} = 1V * 950 / 20mA \text{ (k}\Omega\text{)},$$

$$R_{SET} = 47.5K\Omega$$

PWM Dimming

The LED dimming control is done through the PWM pin. The acceptable frequency range of this signal is 100Hz to 5kHz. The acceptable duty cycle range of the signal is 10% to 90% at 1KHZ. When the PWM pin is driven low, only the LED current sources are disabled while the rest of the chip is still enabled.

Analog dimming control

Besides digital PWM control, the LED current can be controlled continuously (from high to low LED current) by raising the voltage at the bottom of R_{SET} from 0.0V to 1V maximum. R_{SET} value may be determined from equation 1. Equation 2 shows the effect of using a V_{MOD} in the circuit on the Led current

$$I_{LED} = (1V - V_{MOD}) * I_{MULT} / R_{SET} \text{ mA} \quad (2)$$

Where

1V typical I_{SET} pin voltage

I_{MULT} I_{SET} Current Multiplication Ratio

I_{LED} is the desired Led current.

V_{MOD} is the adjustment voltage

V_{MOD} is an adjustment voltage applied to the bottom side of R_{SET}, 950 is a typical current multiplication ratio I_{MULT}, and I_{LED} is a required LED current in mA/channel. Figure 1 shows the location of the external V_{MOD} source.

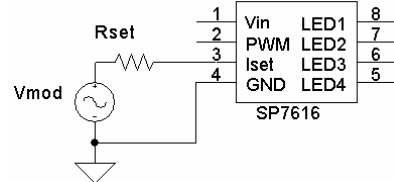

Figure 1

If adjustment voltage V_{MOD} is not used, R_{SET} resistor should be connected to ground.

Shutdown using I_{SET} pin

In normal operation, the voltage at I_{SET} pin is around 1V. To ensure fast turn on at low duty cycle and high PWM frequency, only the output drivers are switching in PWM mode. However, the whole chip can be shutdown by pulling the voltage at I_{SET} up to 3V minimum.

VCC pin Considerations

V_{IN} of the SP7616 (Pin 1) needs to be connected to the anode of the LED for proper operation

Unused Channels and LED 2 Channel (pin 7)

LED 2 channel should never be grounded or left unconnected it should always be used during operation.

Other unused channels can be tied to the ground to save on power consumption.

Shorted LEDs

If all LEDs on a string are shorted, the LED cathode voltage will be V_{IN}. It is still a working condition for this device but it significantly increases the dissipated power.

At 20mA LED current and V_{IN} = 30V additional power dissipated in the package is equal to 600mW that will increase die temperature to 59°C/W x 0.6W = 35.4°C, where 59°C/W is 2x3 mm DFN package thermal resistance. Assuming that all other channels are working at V_{LED} = 1.5V the die temperature will be approximately 41°C above ambient temperature and that decreases operating temperature range. Also to protect the part if too

many LEDs are shorted, and the V_{LED} voltage becomes too high, making the part dissipate too much power, the over temperature protection will shut the part off when the die temperature reaches 150°C . For further information refer to the over-temperature protection section.

Over-temperature protection

The SP7616 offers Over-temperature protection. When the die temperature rises above 150°C the output drivers are shut off. The output current will self recover when the temperature drops below the trip point with the preset hysteresis of 15°C . Thus a part that shut off at 150°C will not try to restart unless the die temperature is below 135°C .

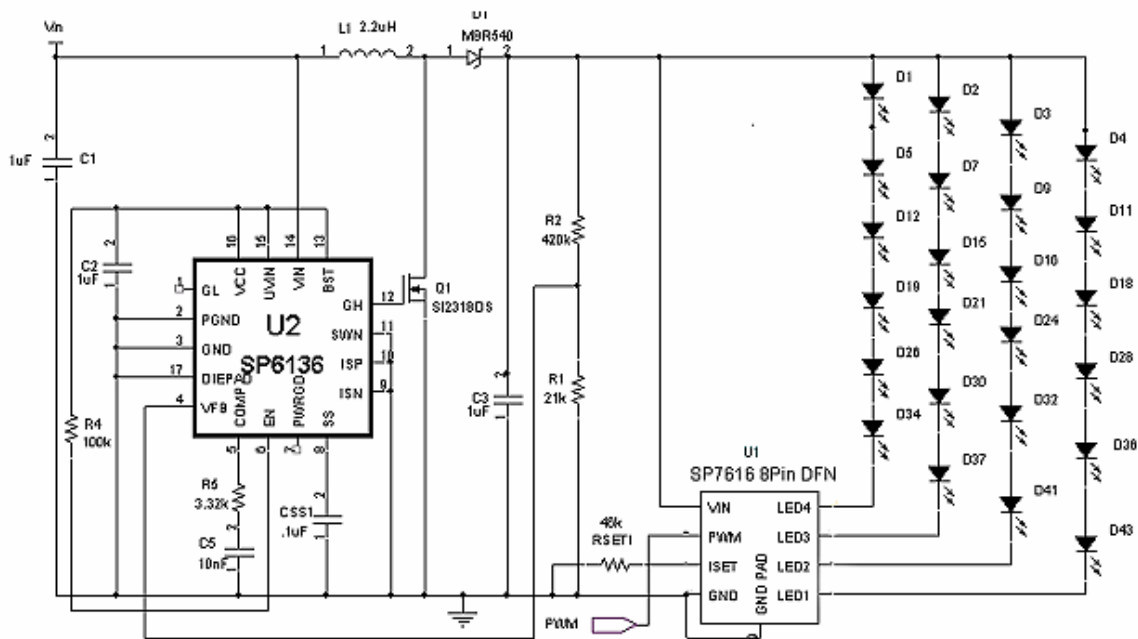

Figure 2
Typical Application: CCFL Replacement powered from 3 Li-ion batteries.

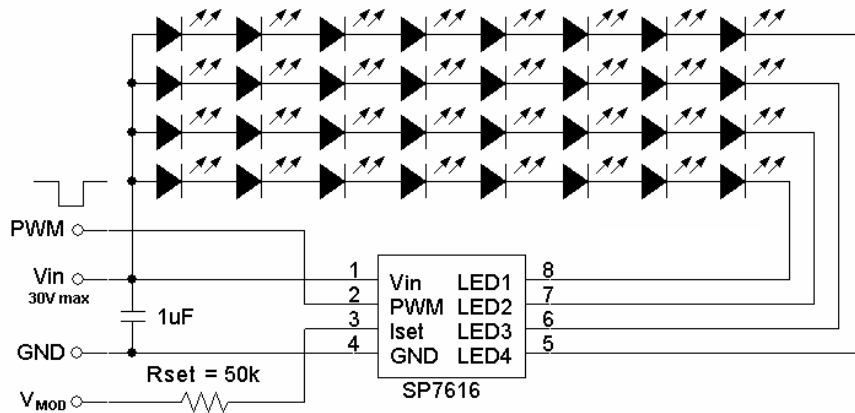
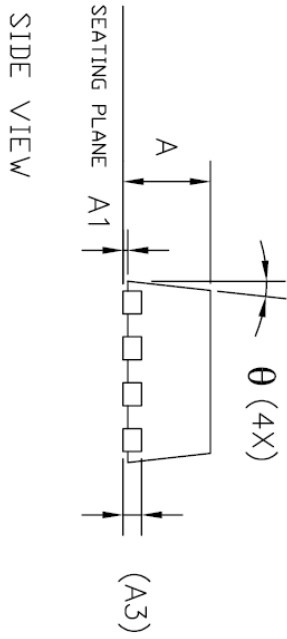
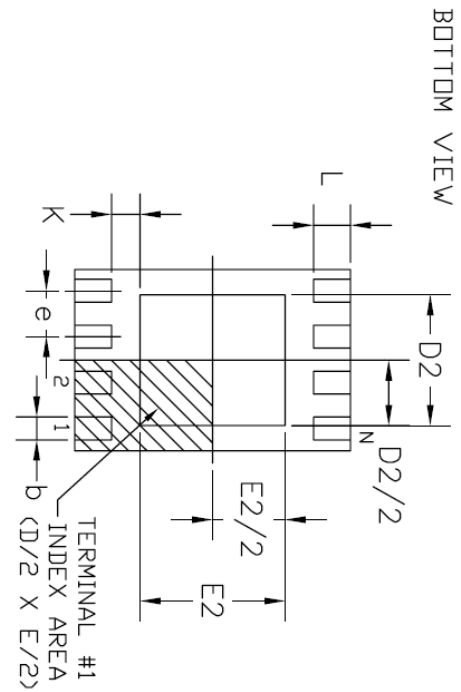
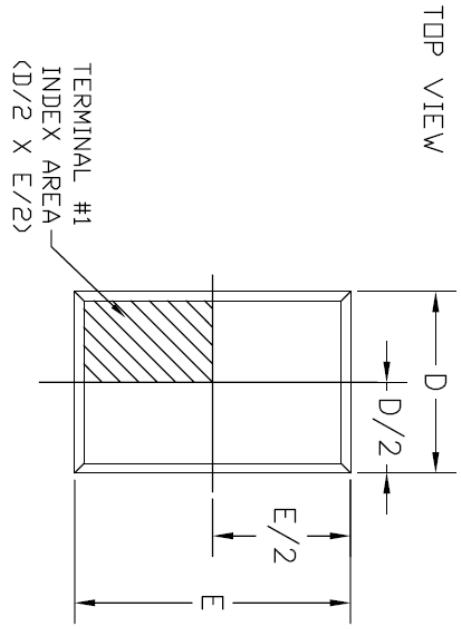

Figure 3
Using the SP7616 from a fixed source.



8LD 2x3 DFN JEDEC MO-229 Variation VCED-2

SYMBOLS	DIMENSIONS IN MM (Control Unit)			DIMENSIONS IN INCH (Reference Unit)		
	MIN	NOM	MAX	MIN	NOM	MAX
A	0.80	0.90	1.00	0.032	0.036	0.039
A1	0.00	0.02	0.05	0.000	0.001	0.002
A3	0.20 REF			0.008 REF		
b	0.18	0.25	0.30	0.007	0.010	0.012
D	2.00 BSC			0.079 BSC		
D2	1.50	—	1.75	0.059	—	0.069
E	3.00 BSC			0.118 BSC		
E2	1.60	—	1.90	0.063	—	0.075
e	0.50 BSC			0.020 BSC		
L	0.30	0.40	0.50	0.012	0.016	0.020
K	0.20	—	—	0.008	—	—
theta	0°	—	14°	0°	—	14°
N	8			8		
ND	4			4		

REVISION HISTORY			
REV	DESCRIPTION	DATE	APP'D
A	DRAWING ORIGINATION	08/18/05	JL
B	MODIFY DRAWING FORMAT	07/17/06	JL

SIPEX CORPORATION

Solved by
Sipex

Packaging Approval:	8 PIN 2x3 DFN PACKAGE OUTLINE
By: JL	Drawing No: 8-PIN 2x3 DFN
Date: 07/17/06	Revision: B
	Sheet: 1 OF 1

ORDERING INFORMATION

Part Number	Temperature Range	Package Type	Pack Type/ Quantity
SP7616ER-L/TR	-40°C to +85°C	Lead Free 6 Pin TSOT	Tape & Reel / 2500
SP7616ER-L	-40°C to +85°C	Lead Free 6 Pin TSOT	Bulk

For further assistance:

Email: Sipexsupport@sipex.com
WWW Support page: <http://www.sipex.com/content.aspx?p=support>
Sipex Application Notes: <http://www.sipex.com/applicationNotes.aspx>



Sipex Corporation

Headquarters and
Sales Office
233 South Hillview Drive
Milpitas, CA95035
tel: (408) 934-7500
FAX: (408) 935-7600

Sipex Corporation reserves the right to make changes to any products described herein. Sipex does not assume any liability arising out of the application or use of any product or circuit described herein; neither does it convey any license under its patent rights nor the rights of others.