

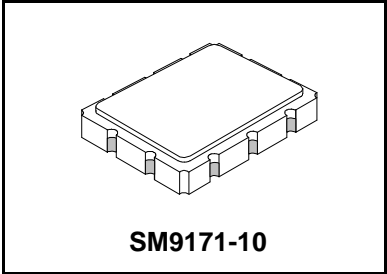

**SF1063A**

**549.00 MHz  
SAW Filter**



- **Designed for CATV Applications (Pilot Tone)**
- **Low Insertion Loss**
- **9.1 x 7.1 mm Surface-Mount Case**
- **Unbalanced Input and Output**
- **Complies with Directive 2002/95/EC (RoHS)**

**Absolute Maximum Ratings**

Rating	Value	Units
Maximum Incident Power in Passband	+10	dBm
Max. DC voltage between any 2 terminals	30	VDC
Storage Temperature Range	-40 to +85	°C
Suitable for lead-free soldering - Max Soldering Profile	260°C for 30 s	

**Electrical Characteristics**

Characteristic	Sym	Notes	Min	Typ	Max	Units	
Nominal Center Frequency	$f_c$	1	549.000			MHz	
Passband	Insertion Loss at fc	1, 2	±100	7.5	9.0	dB	
				0.5 dB Passband			kHz
				3 dB Passband			dB <sub>P-P</sub>
	Amplitude Ripple over fc ±100 kHz			±630	0.5	nS <sub>P-P</sub>	
Rejection	529.04 MHz to 545.75 MHz	1, 2, 3	40			dB	
				551.4 MHz to 569.04 MHz			
				Ultimate			50
Operating Temperature Range	$T_A$	1	-20		+85	°C	

Impedance Matching to 50 Ω unbalanced	External L-C	
Case Style	SM9171-10	9.1 x 7.1 mm Nominal Footprint
Lid Symbolization (XX = 2 character date code)	RFM SF1063A XX	

**Electrical Connections**

Connection	Terminals
Port 1 Hot	10
Port 1 Gnd Return	1
Port 2 Hot	5
Port 2 Gnd Return	6
Case Ground	All others

**Notes:**

1. Unless noted otherwise, all specification apply over the operating temperature range with filter soldered to the specified demonstration board with impedanced matching to 50 Ω network analyzer.
2. Unless noted otherwise, all frequency specifications are referenced to the nominal center frequency,  $f_c$ .
3. Rejection is measured as attenuation below the minimum IL point in the passband. Rejection in final user application is dependent on PCB layout and external impedance matching design. See Application Note No. 42 for details.
4. "LRIP" or "L" after the part number indicates "low rate initial production" and "ENG" or "E" indicates "engineering prototypes."
5. The design, manufacturing process, and specifications of this filter are subject to change.
6. Either Port 1 or Port 2 may be used for either input or output in the design. However, impedances and impedance matching may vary between Port 1 and Port 2, so that the filter must always be installed in one direction per the circuit design.
7. US and international patents may apply.
8. RFM, stylized RFM logo, and RF Monolithics, Inc. are registered trademarks of RF Monolithics, Inc.
9. Electrostatic Sensitive Device. Observe precautions for handling.

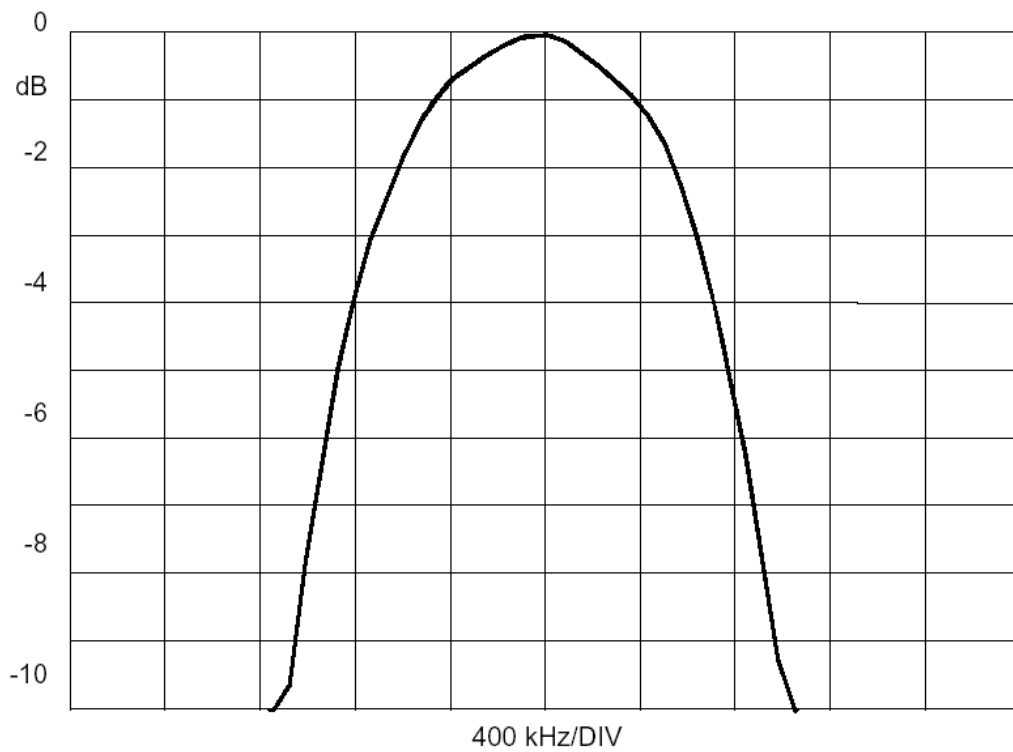
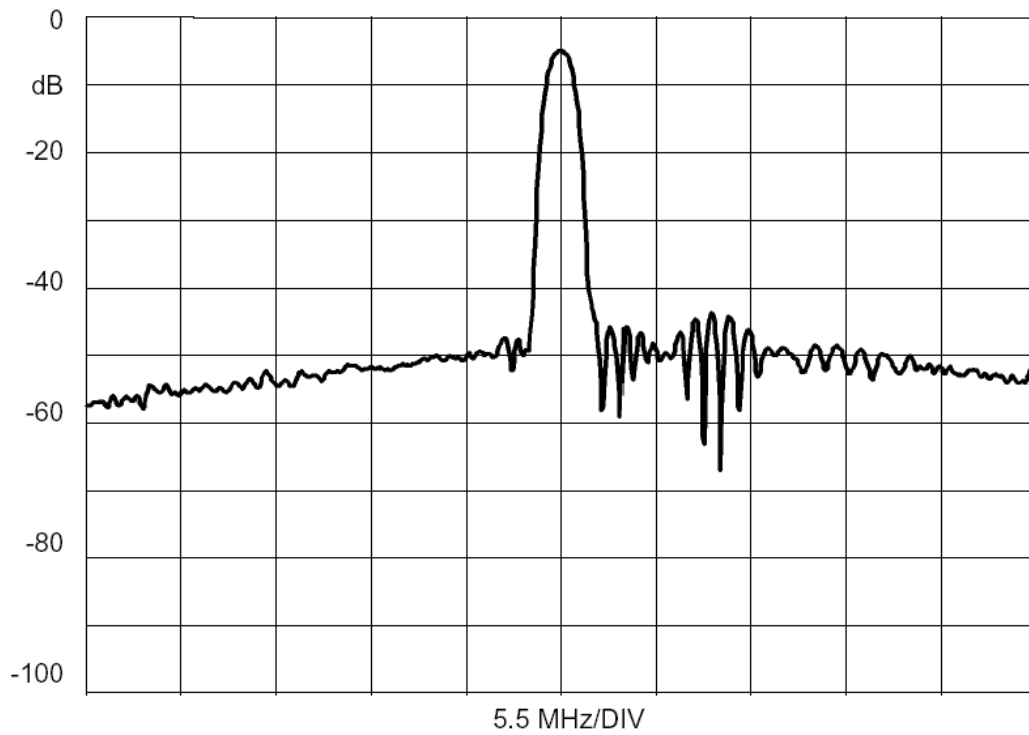

# SM9171-10 Case

## 10-Terminal Ceramic Surface-Mount Case 9.1 x 7.1 mm Nominal Footprint

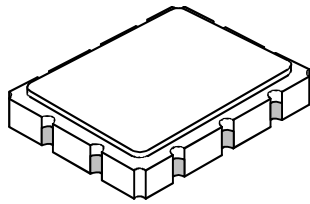

Case Dimensions						
Dimension	mm			Inches		
	Min	Nom	Max	Min	Nom	Max
A	8.86	9.09	9.40	0.349	0.358	0.370
B	6.88	7.11	7.40	0.271	0.280	0.291
C		1.91	2.00		0.075	0.079
D		0.99			0.039	
E		0.79			0.031	
H		1.0			0.039	
P		2.54			0.100	

Materials	
Solder Pad Termination	Au plating 30 - 60 μinches (76.2-152 μm) over 80-200 μinches (203-508 μm) Ni.
Lid	Fe-Ni-Co Alloy Electroless Nickel Plate (8-11% Phosphorus) 100-200 μinches Thick
Body	Al <sub>2</sub> O <sub>3</sub> Ceramic
Pb Free	

Electrical Connections		
Connection		Terminals
Port 1	Input or Return	6
	Return or Input	5
Port 2	Output or Return	1
	Return or Output	10
Ground		All others
Single Ended Operation		Return is ground
Differential Operation		Return is hot

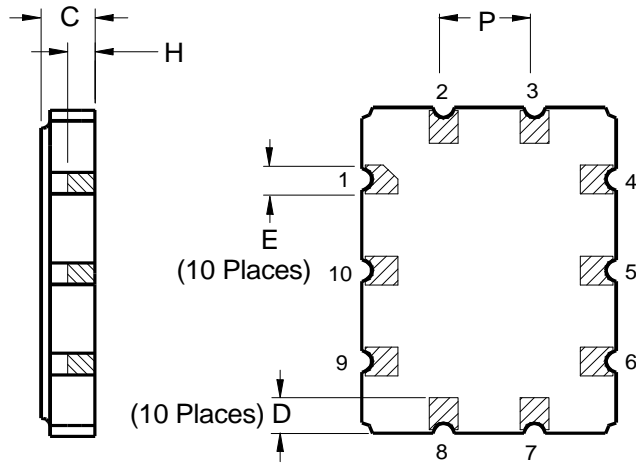
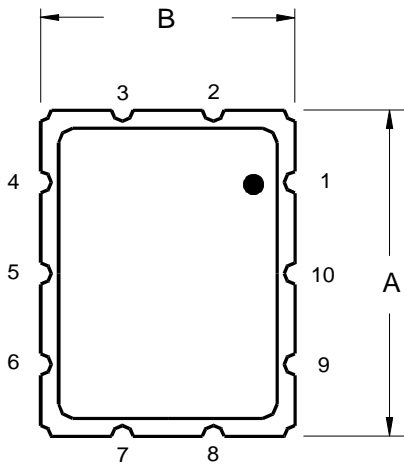

REV	ECN NO.	DESCRIPTION	APP/DATE
A	5073	INITIAL RELEASE	

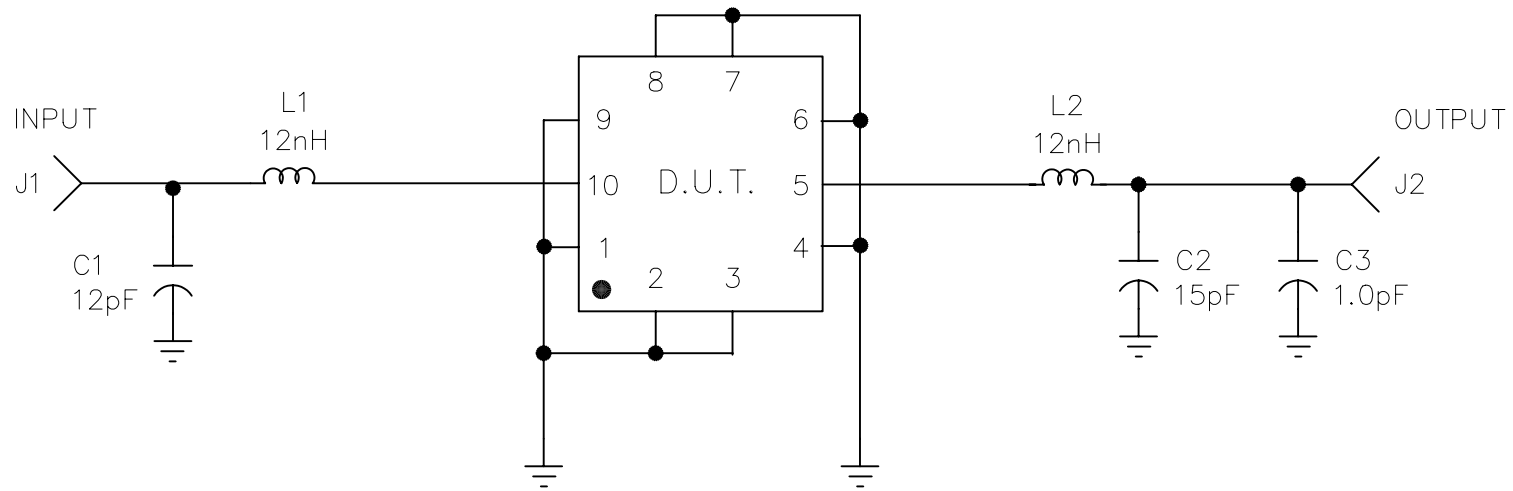

SCHEMATIC

DRAWN BY/DATE: J.J. LAYTON 11/13/96

TITLE: ASSEMBLY DIAGRAM, SF1063(DEMO)

**RF Monolithics, Inc.**  
DALLAS, TEXAS 75244

CHECKED/APPROVED

SIZE CODE IDENT  
**A 2U874**

DWG. NO. SF1063A-000

REV SHEET  
**A 1/6**

NOTES:

1. SOLDER MOUNT COMPONENTS, CONNECTORS, TO PCB1
2. NOTE PROPER ORIENTATION OF INDUCTORS [L1, L2] SHOULD BE 90° TO EACH OTHER.
3. COMPONENTS MAY NEED TO BE TRADED FOR SLIGHTLY HIGHER OR LOWER DUE TO TOLERANCE LEVELS.

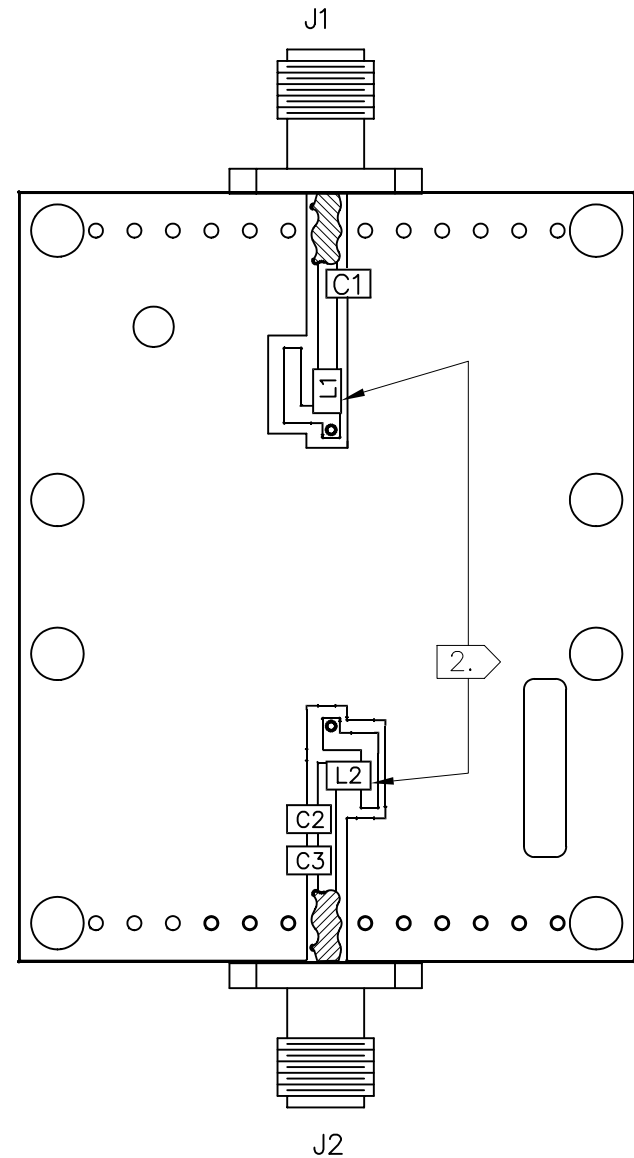
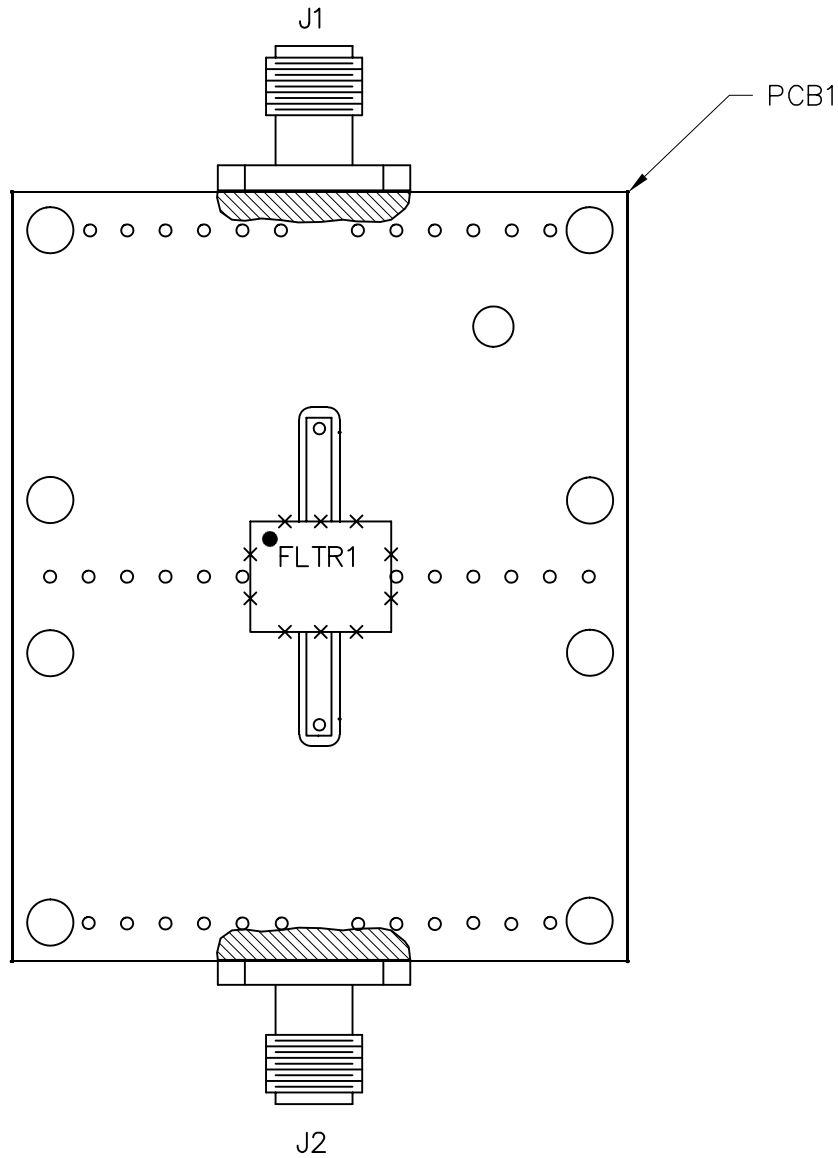

CH1 S<sub>21</sub> log MAG 10 dB/ REF -8 dB L: -5.3028 dB

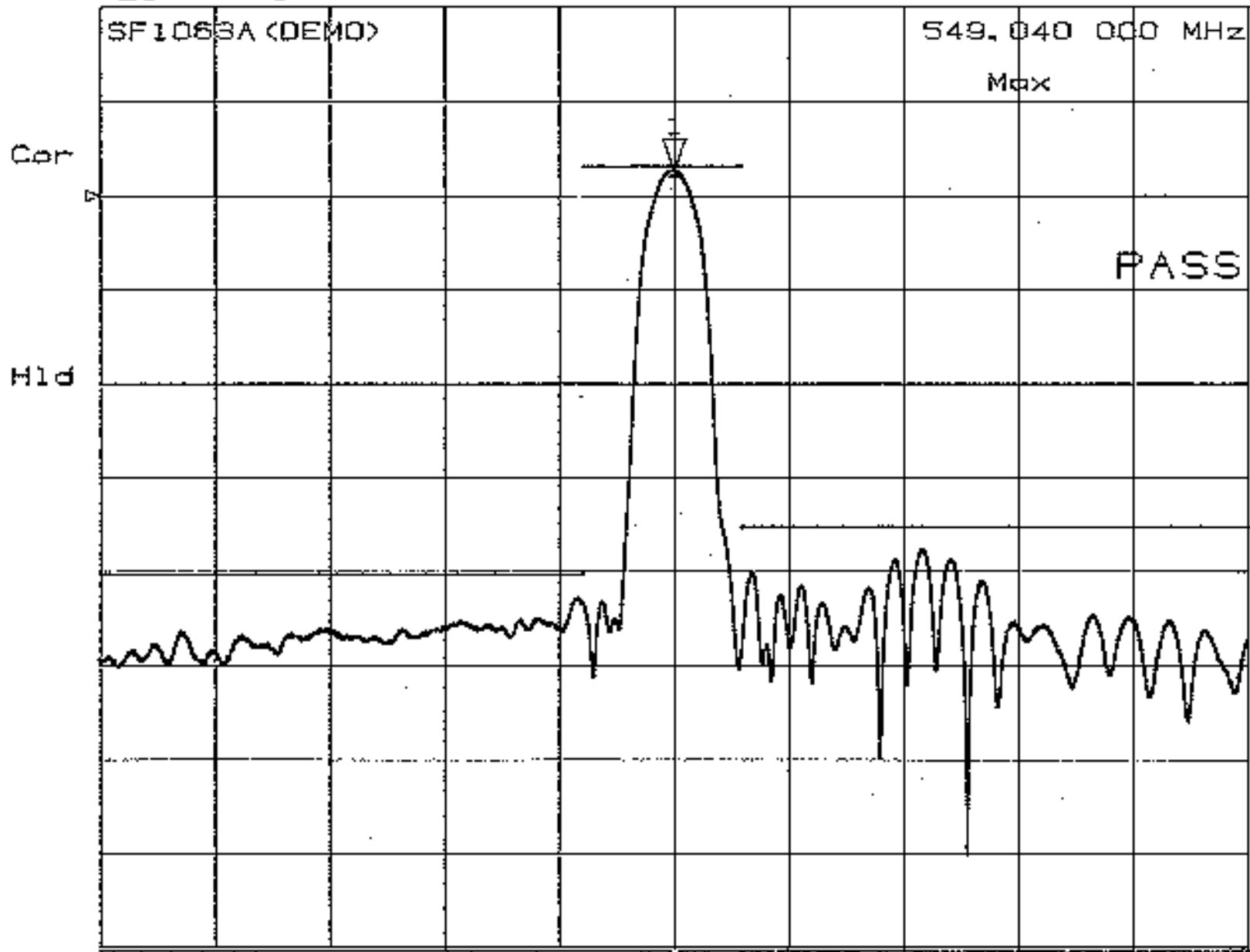

CH1 CENTER 549.040 000 MHz SPAN 40.000 000 MHz

SF1063A-000  
REV: A

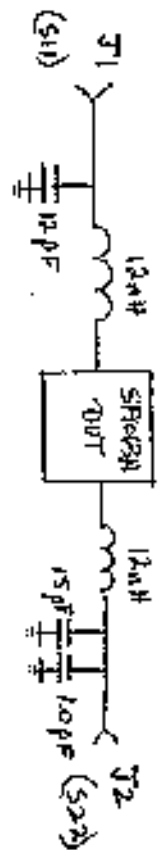

Sheet 3 of 6

CH1 S21 log MAG 5 dB/ REF -8 dB L: 0 dB

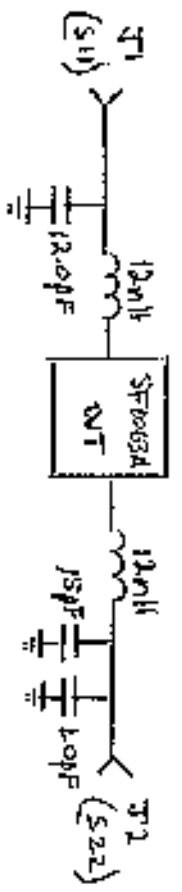
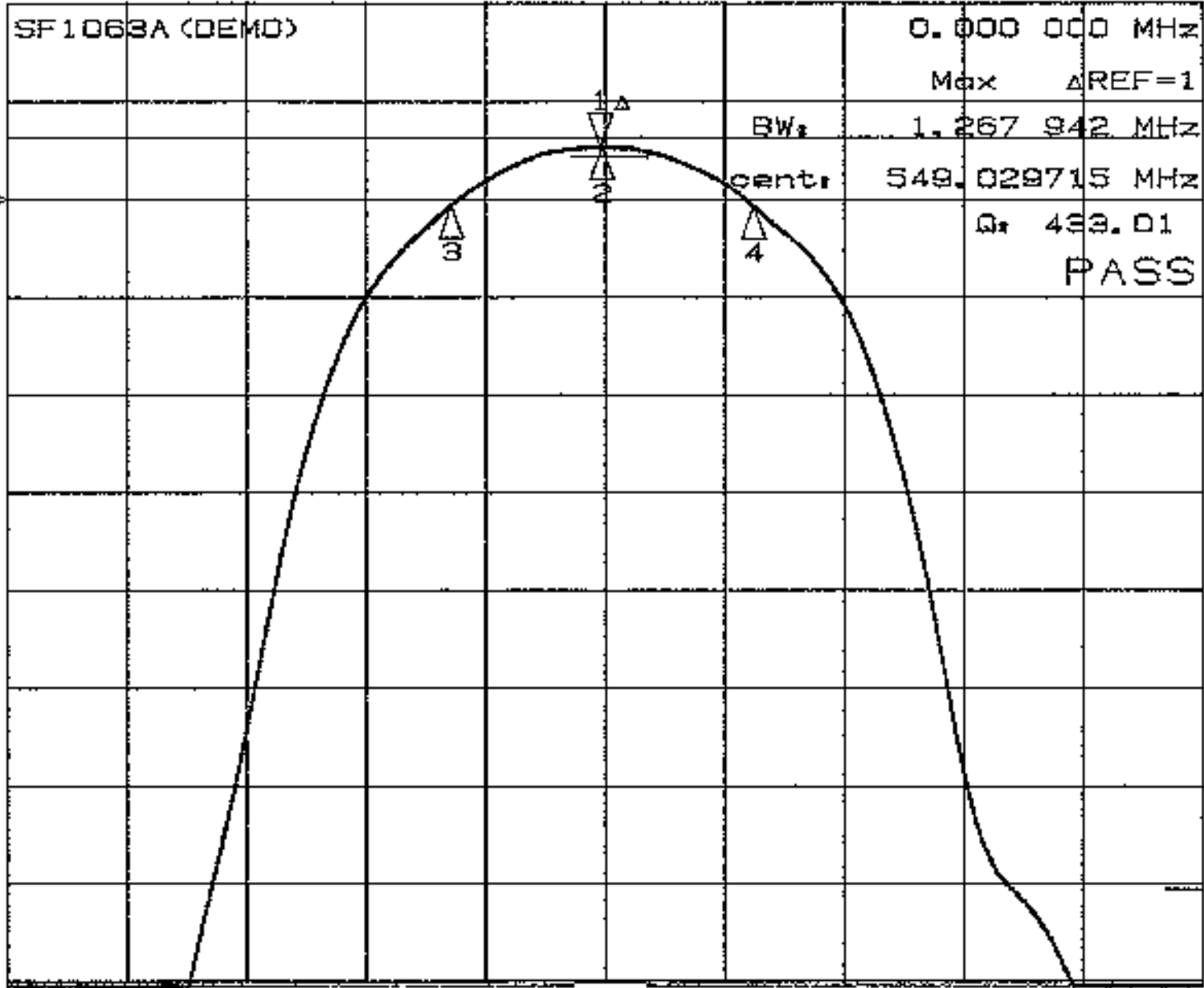

JF1063A-000 JLA 4/8/6  
REV: A

CH1 S<sub>11</sub> 1 U FS 50.299  $\Omega$  1.0801  $\Omega$  313.09  $\mu$ H  
 SF1063A (DEMO) 549.040 000 MHz

Cor

PH

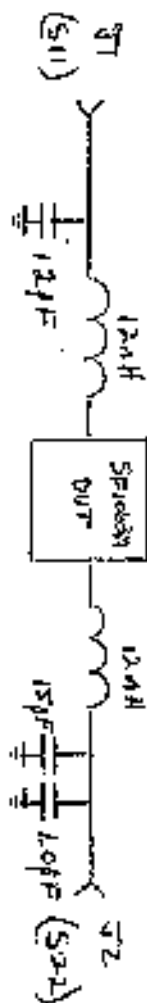
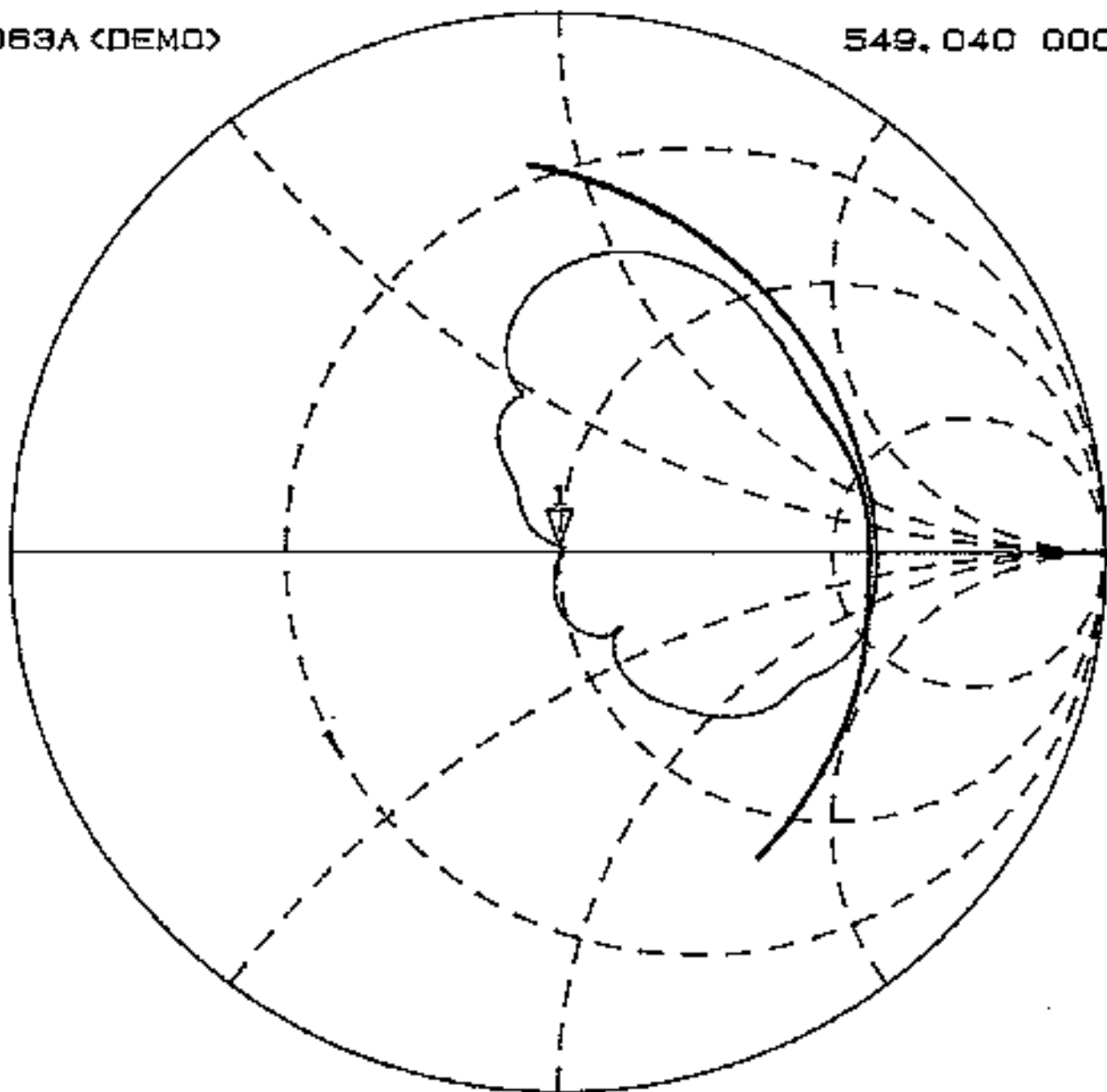

CH1 CENTER 549.040 000 MHz SPAN 40.000 000 MHz

SF1063A-000  
 REV: A

3W 5066



CH1 S<sub>22</sub> 1 U FS L<sub>r</sub> 30.927  $\Omega$  4.1338  $\Omega$  1.1983 nH  
 SF1063A (DEMO) 549.040 000 MHz

Cor

H1d

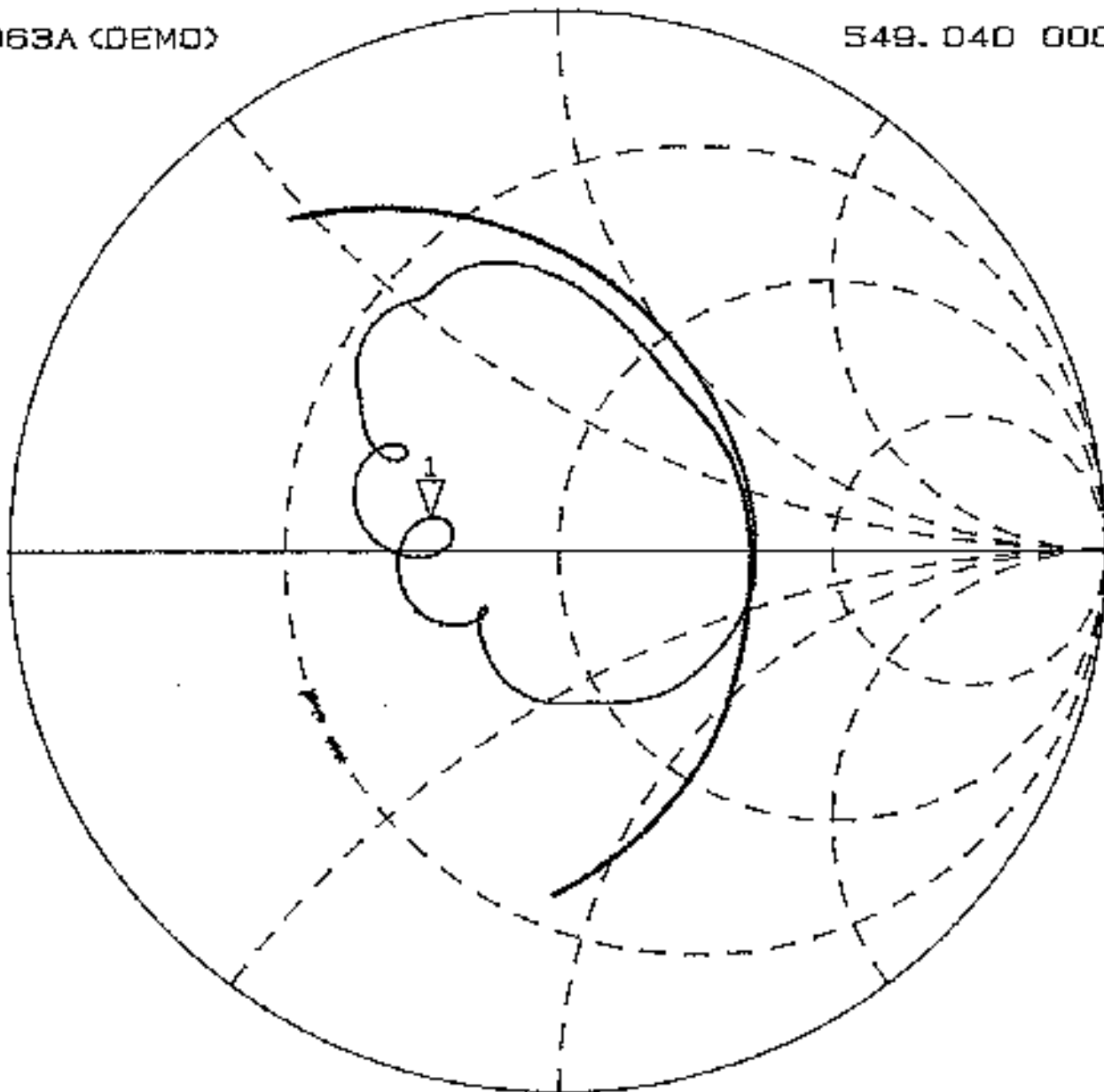

CH1 CENTER 549.040 000 MHz SPAN 40.000 000 MHz

SF1063A-000 STA 6016  
 REV: A

## BILL OF MATERIALS

<u>PART IDENTIFIER</u>	<u>DESCRIPTION 1</u>	<u>DESCRIPTION 2</u>	<u>QTY/ASSY</u>	<u>REFERENCE DESCRIPTION</u>
SF1063A(DEMO)	BOM, DEMOBOARD, SF1063A			
500-0003-120	CAP,CHIP,NPO,12(J),STD		2.0000	C1
500-0003-015	CAP,CHIP,NPO,1.5(C),STD		1.0000	C2
500-0003-010	CAP,CHIP,NPO,1.0(C),STD		1.0000	C3
SF1063A	FILTER,SM,549.000MHZ	C-COR	1.0000	FLTR1
500-0248-001	CONN,COAX,FLANGE MT.JACK		2.0000	J1,2
500-0619-120	IND,CHIP,0603,12NH,10%		2.0000	L1,2
400-0845-001	PCB, SMT FILTER,	TEST FIXTURE	1.0000	PCB1



SIZE  
**A**

FSCM NO.  
**2U874**

DWG NO.  
**SF1063A(DEMO)**

SCALE **NONE**

W/O or ECN **5073**

REV **B**

SHEET **1** OF **2**

**REV HISTORY**

REV	ECN	DATE	DESCRIPTION
A	4805	06/12/96	INITIAL RELEASE
B	5073	10/23/96	UPDATE AND MOVE ASSEMBLY DIAGRAM TO SEPARATE DOCUMENT

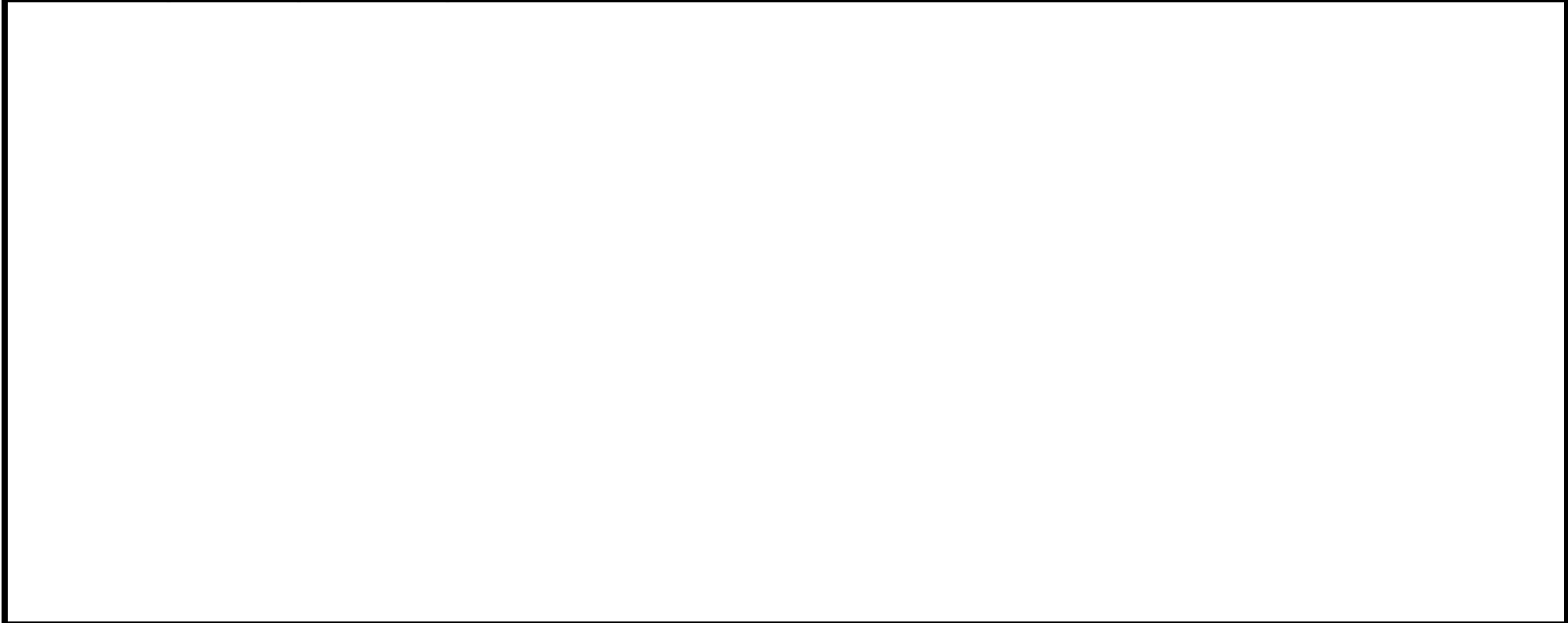

	SIZE <b>A</b>	FSCM NO. <b>2U874</b>	DWG NO. <b>SF1063A(DEMO)</b>	
	SCALE <b>NONE</b>	W/O or ECN <b>5073</b>	REV <b>B</b>	SHEET <b>2</b> OF <b>2</b>