

# High Speed Thermal Printhead (8dots / mm)

## SE2003-DC90A

High speed, high quality, and high durability are achieved by using step free structure with high performance partial glaze and highly conductive overcoat layer. SE200\*-DC90A series are lined up which can accommodate with all types of barcode labeling printers from Direct to Thermal Transfer, normal to high speed (over 300mm/s).

### ●Applications

Bar code label printers

Ticket printers

General purpose compact printers

### ●Features

- 1) ROHM new technology "STEP FREE" structure will provide, high corrosion resistance, better resistance against scratching damage, high efficiency.
- 2) Standard glazed components to accommodate thick paper.
- 3) High speed clock (10MHz) to facilitate external heat history control.
- 4) Using a hard conductive film as a protective film on the heating element offers excellent resistance to electrostatic damage.
- 5) Compatible with the SE3003-DC90A 300dpi in mechanical specifications, to facilitate the making of a series of printers.

### ●External dimensions (Unit : mm)

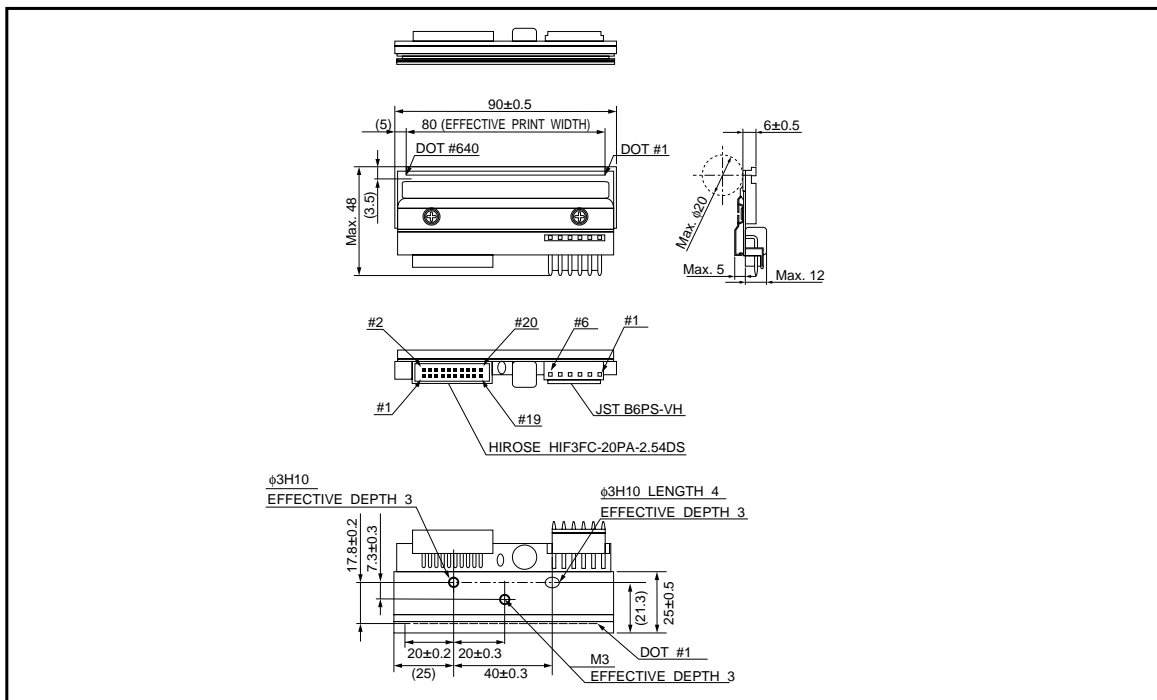

Note: No heat history control function inside the thermal printhead. External heat history control is required for high speed printing.

## Printheads

---

### ●Characteristics

Parameter	Symbol	Typical	Unit
Effective printing width	–	80	mm
Dot pitch	–	0.125	mm
Total dot number	–	640	dots
Average resistance value	Rave	550	$\Omega$
Applied voltage	V <sub>H</sub>	24	V
Applied power	P <sub>o</sub>	0.899	W / dot
Print cycle	SLT	0.42	ms
Maximum number of dots energized simultaneously	–	448	dots
Maximum clock frequency	–	10	MHz
Maximum roller diameter	–	20	mm
Running life / pulse life	–	50 / 10 <sup>8</sup>	km / pulses
Operating temperature	–	5 to 45	°C

### ●Pin configuration

#### HIROSE

No.	Circuit	No.	Circuit
1	V <sub>DD</sub>	2	BEO
3	GND	4	DI2
5	N.C.	6	CLK
7	$\overline{LA}$	8	GND
9	GND	10	DI1
11	N.C.	12	GND
13	V <sub>DD</sub>	14	$\overline{STB2}$
15	$\overline{STB1}$	16	TM
17	TM	18	SENS1
19	SENS2	20	SENS3

#### JST

No.	Circuit
1	VH
2	VH
3	VH
4	GND
5	GND
6	GND

## Printheads

## ●Timing chart

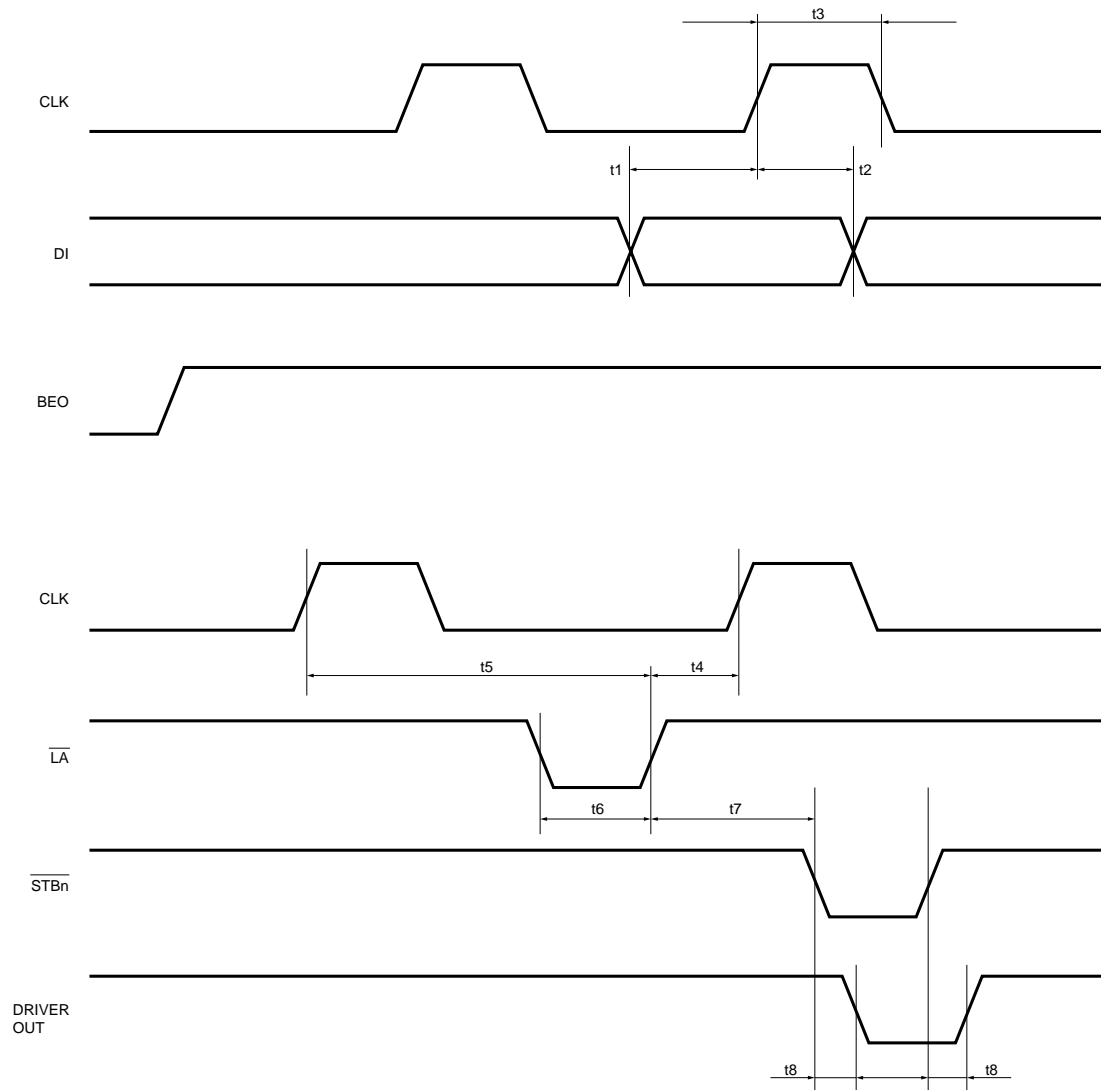
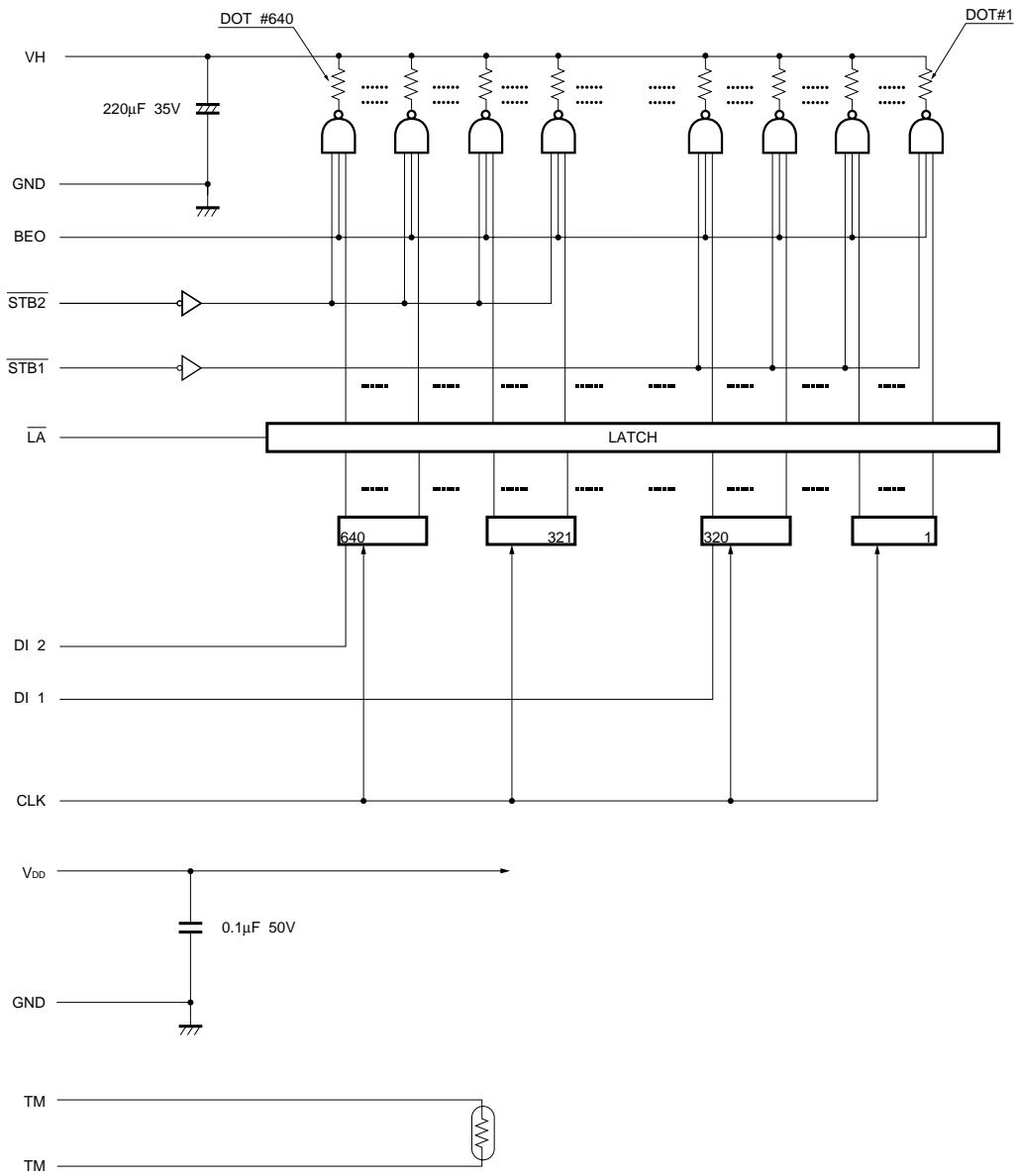

Fig.1

Printheads

●Equivalent circuit



DI No.	DOT No.	$\overline{\text{STB}} \text{ No.}$	DOT No.
DI 2	640 to 321	$\overline{\text{STB}} \text{ 2}$	640 to 321
DI 1	320 to 1	$\overline{\text{STB}} \text{ 1}$	320 to 1

Fig. 2

Printheads

●Electrical characteristics curves

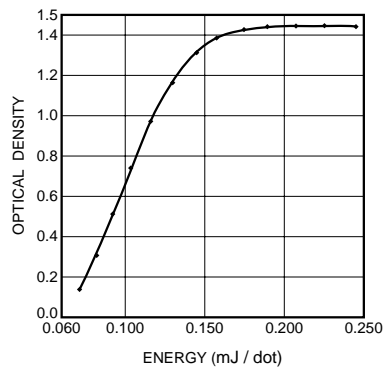

Fig. 3 Representative density curve

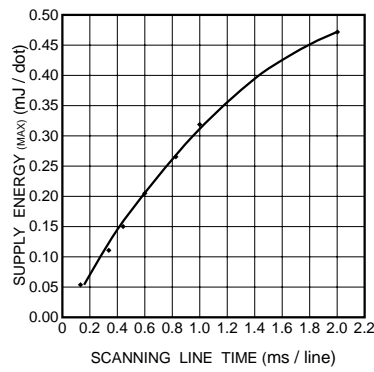

Fig. 4 Maximum energy curve

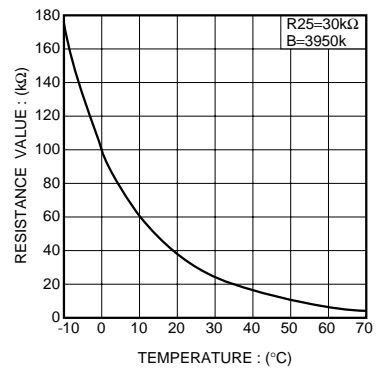

Fig. 5 Thermistor curve

### Notes

- No technical content pages of this document may be reproduced in any form or transmitted by any means without prior permission of ROHM CO.,LTD.
- The contents described herein are subject to change without notice. The specifications for the product described in this document are for reference only. Upon actual use, therefore, please request that specifications to be separately delivered.
- Application circuit diagrams and circuit constants contained herein are shown as examples of standard use and operation. Please pay careful attention to the peripheral conditions when designing circuits and deciding upon circuit constants in the set.
- Any data, including, but not limited to application circuit diagrams information, described herein are intended only as illustrations of such devices and not as the specifications for such devices. ROHM CO.,LTD. disclaims any warranty that any use of such devices shall be free from infringement of any third party's intellectual property rights or other proprietary rights, and further, assumes no liability of whatsoever nature in the event of any such infringement, or arising from or connected with or related to the use of such devices.
- Upon the sale of any such devices, other than for buyer's right to use such devices itself, resell or otherwise dispose of the same, no express or implied right or license to practice or commercially exploit any intellectual property rights or other proprietary rights owned or controlled by
- ROHM CO., LTD. is granted to any such buyer.
- Products listed in this document are no antiradiation design.

The products listed in this document are designed to be used with ordinary electronic equipment or devices (such as audio visual equipment, office-automation equipment, communications devices, electrical appliances and electronic toys).

Should you intend to use these products with equipment or devices which require an extremely high level of reliability and the malfunction of which would directly endanger human life (such as medical instruments, transportation equipment, aerospace machinery, nuclear-reactor controllers, fuel controllers and other safety devices), please be sure to consult with our sales representative in advance.

#### About Export Control Order in Japan

Products described herein are the objects of controlled goods in Annex 1 (Item 16) of Export Trade Control Order in Japan.

In case of export from Japan, please confirm if it applies to "objective" criteria or an "informed" (by MITI clause) on the basis of "catch all controls for Non-Proliferation of Weapons of Mass Destruction.