

**SINGLE PHASE BIDIRECTIONAL POWER/ENERGY  
METERING IC WITH SERIAL INTERFACE**

**FEATURES**

- Performs bidirectional active and reactive power/energy, frequency and voltage measurement
- Meets the IEC 521/1036 Specification requirements for Class 1 AC Watt hour meters
- Protected against ESD
- Total power consumption rating below 25mW
- Adaptable to different current sensor technologies
- Operates over a wide temperature range
- Serial interface having a RS232 protocol
- Precision voltage reference on-chip
- Tri-state output to allow parallel connection of devices

**DESCRIPTION**

The SAMES SA9603C bidirectional single phase power/energy metering integrated circuit has a serial interface with a RS232 protocol, ideal for use with a  $\mu$ -Controller. The SA9603C performs the calculation for active and reactive power.

The SA9603C is a direct replacement for the SA9103C with additional features for the fast reading of all register values.

The integrated values for active and reactive energy as well as the mains frequency and voltage information are accessible through the serial interface as 16 bit values.

This universal single phase power/energy metering integrated circuit is ideally suited for energy calculations in applications such as electricity dispensing systems (ED's), residential municipal metering and factory energy metering and control.

The SA9603C integrated circuit is available in both 14 and 20 pin dual-in-line plastic

(DIP-14/DIP-20), as well as 20 pin small outline (SOIC-20) package types.

**PIN CONNECTIONS**

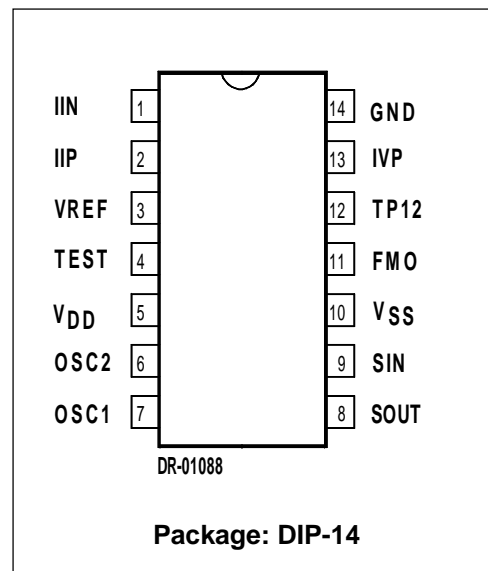

## SA9603C

### PIN CONNECTIONS

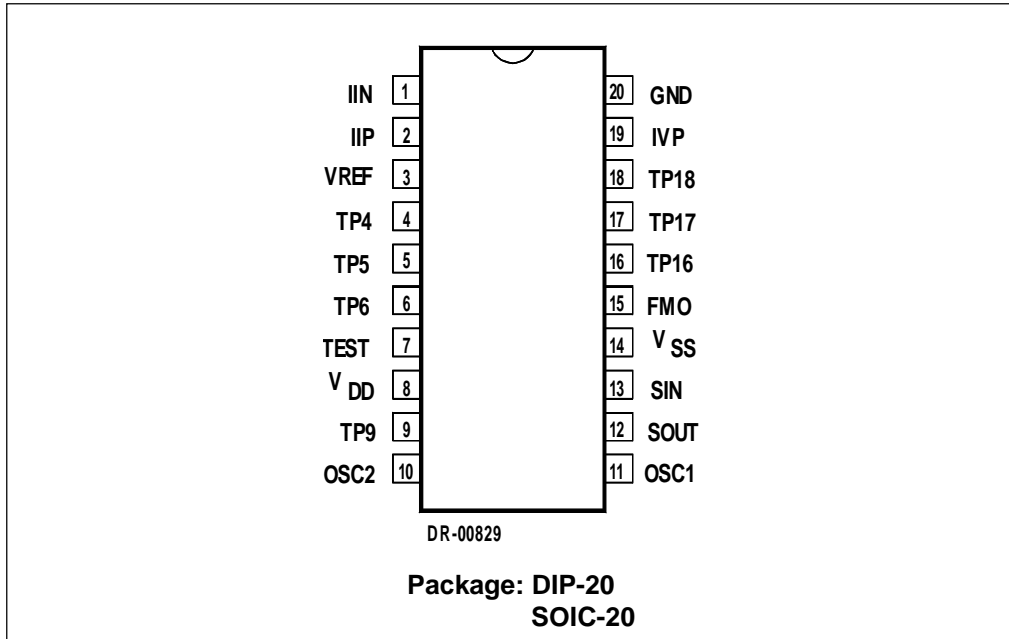

### BLOCK DIAGRAM

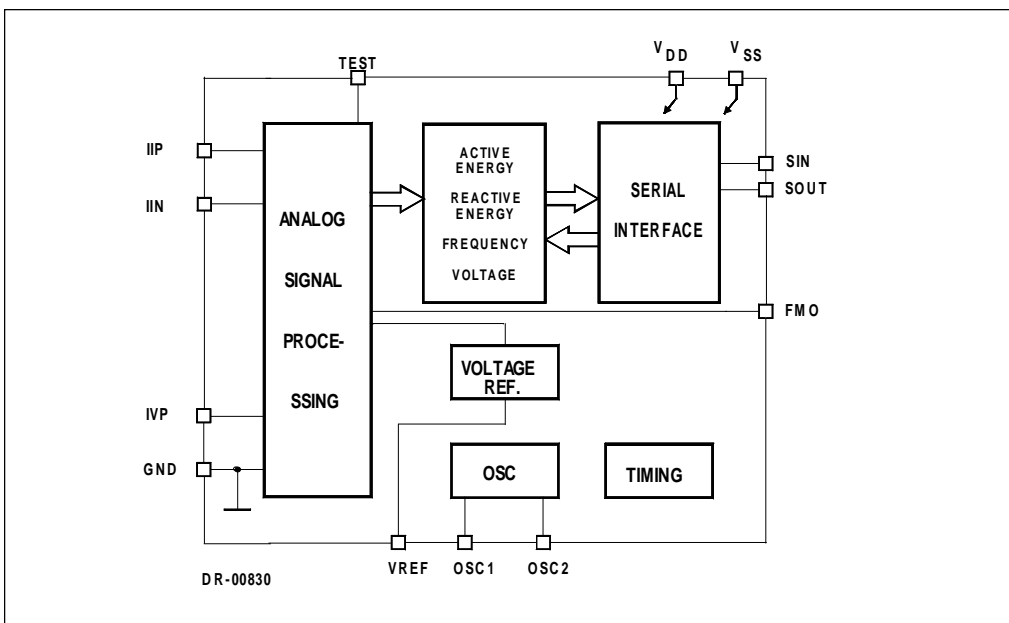

**ABSOLUTE MAXIMUM RATINGS\***

Parameter	Symbol	Min	Max	Unit
Supply Voltage	$V_{DD} - V_{SS}$	-0.3	6.0	V
Current on any pin	$I_{PIN}$	-150	+150	mA
Storage Temperature	$T_{STG}$	-40	+125	°C
Operating Temperature	$T_O$	-10	+70	°C

\* Stresses above those listed under “Absolute Maximum Ratings” may cause permanent damage to the device. This is a stress rating only. Functional operation of the device at these or any other condition above those indicated in the operational sections of this specification, is not implied. Exposure to Absolute Maximum Ratings for extended periods may affect device reliability.

**SA9603C****ELECTRICAL CHARACTERISTICS**

( $V_{DD} = 2.5V$ ,  $V_{SS} = -2.5V$ , over the temperature range  $-10^{\circ}C$  to  $+70^{\circ}C^{\#}$ , unless otherwise specified.)

Parameter	Symbol	Min	Typ	Max	Unit	Condition
Supply Voltage: Positive	$V_{DD}$	2.25		2.75	V	
Supply Voltage: Negative	$V_{SS}$	-2.75		-2.25	V	
Supply Current: Positive	$I_{DD}$		5	6	mA	
Supply Current: Negative	$I_{SS}$		5	6	mA	
Current Sensor Inputs (Differential)						
Input Current Range	$I_{II}$	-25		+25	$\mu A$	Peak value
Voltage Sensor Input (Asymmetrical)						
Input Current Range	$I_{IV}$	-25		+25	$\mu A$	Peak value
Pin FMO Output Low Voltage Output High Voltage	$V_{OL}$ $V_{OH}$	$V_{DD}-1$		$V_{SS}+1$	V V	$I_{OL} = 5mA$ $I_{OH} = -2mA$
Pin SIN Input High Voltage Input Low Voltage Pull-up Current	$V_{IH}$ $V_{IL}$ $-I_I$	$V_{DD}-1$  50		$V_{SS}+1$ 150	V V $\mu A$	$V_{IN} = V_{SS}$
Pin SOUT Output Low Voltage Output High Voltage	$V_{OL}$ $V_{OH}$	$V_{DD}-1$		$V_{SS}+1$	V V	Tri-state
Oscillator	Recommended crystal: TV colour burst crystal $f = 3.5795$ MHz					
Pin VREF Ref. Current Ref. Voltage	$-I_R$ $V_R$	45 1.1	50	55 1.3	$\mu A$ V	With $R = 24k\Omega$ connected to $V_{SS}$ Referred to $V_{SS}$

# Extended Operating Temperature Range available on request.



**PIN DESCRIPTION**

14 Pin	20 Pin	Designation	Description
14	20	GND	Ground
5	8	V <sub>DD</sub>	Positive Supply Voltage
10	14	V <sub>SS</sub>	Negative Supply Voltage
13	19	IVP	Analog input for mains voltage
1	1	IIN	Inputs for current sensor
2	2	IIP	
7	11	OSC1	Connections for crystal or ceramic resonator (OSC1 = Input ; OSC2 = Output)
6	10	OSC2	
8	12	SOUT	Serial Interface Out
9	13	SIN	Serial Interface In
3	3	VREF	Connection for current setting resistor
4	7	TEST	Test Pin. Must be connected to V <sub>SS</sub>
11	15	FMO	Mains frequency zero-crossing indication
	4	TP4	Test Pins (Leave unconnected)
	5	TP5	
	6	TP6	
	9	TP9	
12		TP12	
	16	TP16	
	17	TP17	
	18	TP18	

**FUNCTIONAL DESCRIPTION**

The SA9603C is a CMOS mixed signal Analog/Digital integrated circuit, which performs power/energy calculations across a power range of 1000:1, to an overall accuracy of better than Class 1.

The integrated circuit includes all the required functions for 1-phase power and energy measurement, such as two oversampling A/D converters for the voltage and current sense inputs, power calculation and energy integration. Internal offsets are eliminated through the use of cancellation procedures. The SA9603C integrates the measured active and reactive power consumption into 22 bit integrators, which are accessible via a serial port having a RS232 protocol. Two additional on-chip registers exist: one register contains the mains frequency information; and the other the voltage information.

**1. Power Calculation**

In the Application Circuit (Figure 1), the voltage drop across the shunt will be between 0 and  $16\text{mV}_{\text{RMS}}$  (0 to 80A through a shunt resistor of  $200\mu\Omega$ ). This voltage is converted to a current of between 0 and  $16\mu\text{A}_{\text{RMS}}$ , by means of resistors  $R_1$  and  $R_2$ .

The current sense input saturates at an input current of  $\pm 25\mu\text{A}$  peak.

For the voltage sensor input, the mains voltage (230V AC) is divided down through a divider to  $14\text{V}_{\text{RMS}}$ . The resulting current into the A/D converter input is  $14\mu\text{A}_{\text{RMS}}$  at nominal voltage, via resistor R4 ( $1\text{M}\Omega$ ).

In this configuration, with a mains voltage of 230V and a current of 80A, the SA9603C functions at its optimum conditions, having a margin of 3dB for overload available.

**2. Analog Input Configuration**

The input circuitry of the current and voltage sensor inputs are illustrated below. These inputs are protected against electrostatic discharge through clamping diodes.

The feedback loops from the outputs of the amplifiers  $A_I$  and  $A_V$  generate virtual shorts on the signal inputs. Exact duplications of the input currents are generated for the analog signal processing circuitry.

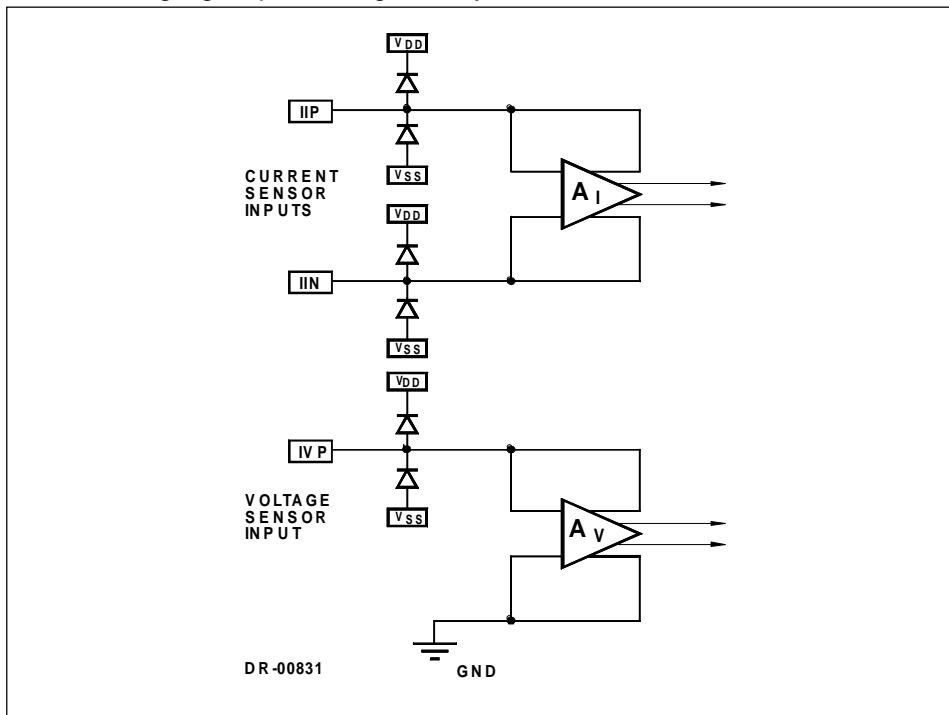

**3. Electrostatic Discharge (ESD) Protection**

The SA9603C integrated circuit's inputs/outputs are protected against ESD .

**4. Power Consumption**

The power consumption rating of the SA9603C integrated circuit is less than 25mW.

**5. Serial Interface**

Reading and resetting of the SA9603C's on-chip integrators, is performed via the serial interface.

The settings are:   19 200 Baud  
                          1 Start bit (S)  
                          1 Stop bit (E)  
                          No parity bits

The serial interface, having a RS232 protocol, has been designed to operate directly with a PC (Personal Computer).

The serial interface allows for the following operations:

**Read Integrator (RD):** The SA9603C integrated circuit transmits the integrator status to the controller, after the current measurement cycle has been completed (8 mains periods maximum).

The register containing the mains frequency information is read only.

**Reset Integrator (RES):** The SA9603C integrator is reset, without transmitting the integrator status.

**Read/Reset Integrator (RD/RES):** The SA9603C transmits the integrator status and resets the integrator after the current measurement cycle has been completed.

In a typical application, the system controller monitors the status of the SA9603C's integrator using the "Read" command. At rated load conditions, the capacity of the 22 bit integrator allows for an integration time of 2 seconds, prior to integrator overflow.

If after a "Read" command, the integrator value is sufficiently high, a "Read/Reset" command from the controller causes the SA9603C integrated circuit to complete the existing measurement cycle, transmit the most significant bits of the 22 bit integrator via the Serial Output (SOUT) to the controller and restart the integrator.

In order to ensure correct measurements, the integrator commands ("Read" and "Read/Reset") are only executed after completion of the internal offset calibration cycle. The cycle length is 8 mains periods.

Thus, for power calculations, the time value should be taken from the difference in time from the previously received energy value to the currently received value.

By adapting the "Read/Reset" rate to the line current, the accuracy of the measurement can be achieved down to lowest signal levels.

**Dump register values:** The content of the individual registers are transmitted sequentially, at the 'Dump' command. Transmission of the first register value will start with the completion of the current measurement cycle (Maximum 8 mains cycles). The sequence of the registers is always as follows: Mains voltage, mains frequency, reactive energy register followed by the active energy register value. By specifying the register in the DUMP command, register values are transmitted starting with the specified register and stopping with the active energy register.

**Commands for the active energy integrator**

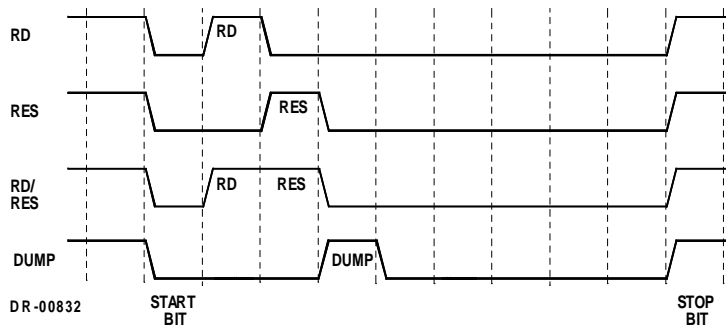

**Commands for the reactive energy integrator**

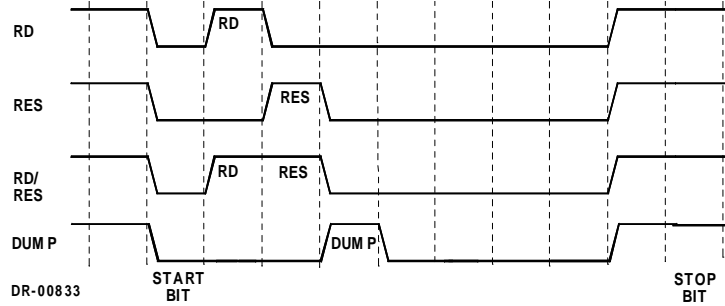

**Commands for the frequency register**

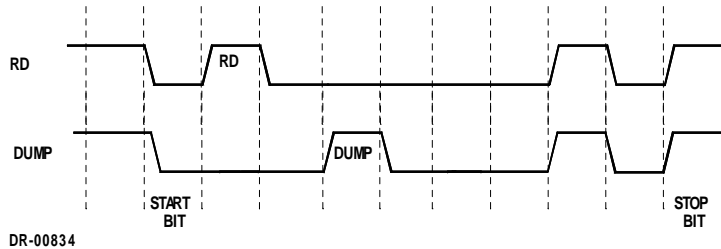



**Commands for the voltage integrator**

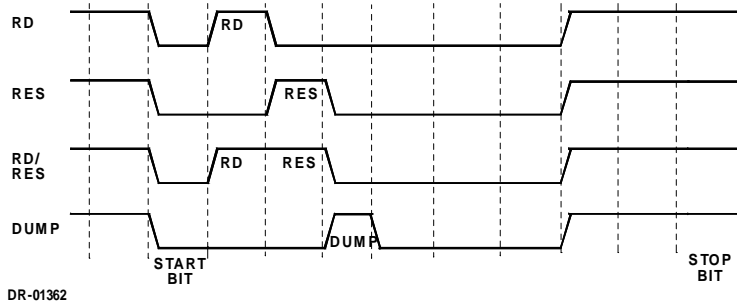

The register access codes which may be written to the SA9603C via the serial communications port, are shown in the table below:

REGISTER	READ	RESET	READ-RESET	DUMP
ACTIVE	\$01	\$02	\$03	\$05#
RE-ACTIVE	\$81	\$82	\$83	\$84
FREQUENCY	\$41	-	-	\$44
VOLTAGE	\$C1	\$C2	\$C3	\$C4

#Note: The Dump Active (\$04) and Read Active (\$01) commands have the same effect.

**Data on SOUT**

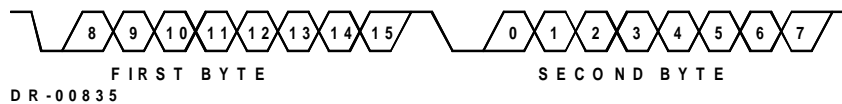

From the two bytes of data output by the device, the value for the register can be derived as shown:

$$\text{Register value} = (\text{First Byte} * 256) + \text{Second Byte}$$

The register value is represented in two's compliment in order to provide for positive and negative register values. The most significant bit of the 16 bit energy register (active or reactive) may be used as an indication of the direction of the energy flow (0 = positive, 1 = negative).

**6. Register Values**

- a. The active and reactive energy measured per count, may be calculated by applying the following formula:

$$\text{Energy per Count} = \frac{V * I}{K} \text{ Watt seconds}$$

Where

V	=	Rated Voltage
I	=	Rated Current
K	=	9281 for Active Energy
		$\frac{9281 * 2}{\pi}$ for Reactive Energy

- b. The mains frequency may be calculated as follows:

$$\text{Frequency} = \frac{\text{Crystal frequency}}{\text{Register Value} * 8}$$

- c. To calculate the measured voltage, the following formula may be used:

$$V_{\text{measured}} = \frac{V * n}{14000 * t}$$

Where

V	=	rated mains voltage
t	=	time difference between successive reads
n	=	difference in register values between successive reads

**7. Software Flow**

The SA9603C is able to execute code written for the SA9103C without any modifications. (Ensure that only bits of the serial command to the device is set that need to be set.)

It is suggested that the DUMP command is used in cases where more than one register is continuously read. The DUMP command initiates a serial transmission of successive register values, starting with the specified register. The Dump command does not reset the register values.

New software should be developed in such a way that registers are never resettled and must allow for register overflow. Register overflow is easily taken into account by software running on a controlling microcontroller. The software subtracts the previous register value from the current register value in order to determine the actual change in register value. Note that the mains frequency register value only needs to be scaled, in order to calculate the true mains frequency in Hertz.

The SA9603C integrated circuit only transmits the register values after completion of the current measurement cycle (8 mains periods maximum).

The delay of 8 mains periods may be calculated from the period value of the frequency returned by the initial read, and updated with each subsequent frequency reading.



## 8. Calibration

For calibration of the SA9603C, the following procedure is recommended:

- a. Establish the calibration factor for active energy (Ka) at power factor (PF) close to 1.

$$\text{Active (Measured)} = \text{register\_value (Active)} * \text{Ka.} \quad (1)$$

- b. The factor for reactive (Kr) is typically  $\text{Ka} * \text{PI}/2$ .  
For higher accuracy of Kr, establish Kr at PF close to 0.

$$\text{Reactive (Measured)} = \text{register\_value (Reactive)} * \text{Kr} \quad (2)$$

- c. At PF close to 1, establish error for reactive (Er)

$$\text{Er} = (\text{Reactive (Measured)} - \text{Reactive (True)}) / \text{Active (Measured)} \quad (3)$$

$$\text{Reactive (Corrected)} = \text{Reactive (Measured)} - \text{Er} * \text{Active (Measured)} \quad (3b)$$

### Measurement

Having determined the scaling factors (Ka & Kr) and error correction constant (Er) the measurement cycle consists of the following steps:

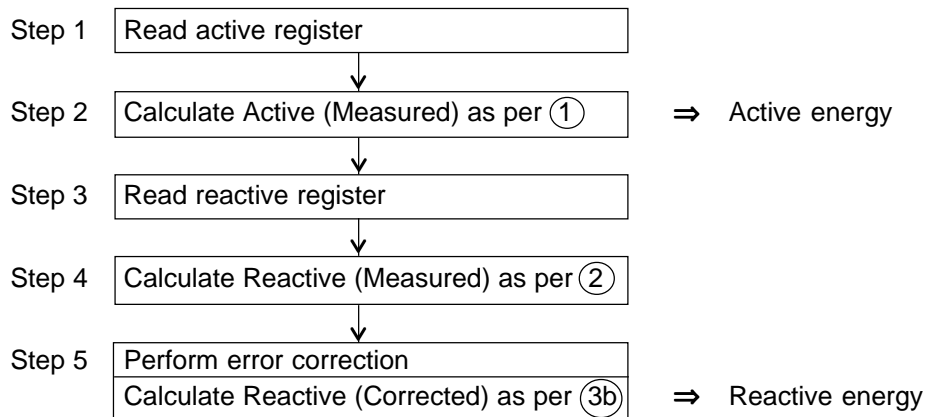

The above five steps must be performed for each measurement cycle.

**TYPICAL APPLICATIONS**

In the Application Circuits (Figures 1 and 2), the components required for power metering applications, are shown.

In Figure 1, a shunt resistor is used for current sensing. In this application, the circuitry requires a +2.5V, 0V, -2.5V DC supply.

In the case of Figure 2, when using a current transformer for current sensing, a +5V, 0V DC supply is sufficient for the circuit.

$R_1$ ,  $R_2$  and RSH are the resistors defining the current level into the current sense input. The values should be selected for an input current of  $16\mu A_{RMS}$  into the SA9603C at rated line current.

Values for RSH of less than  $200\mu\Omega$  should be avoided.

$$R_1 = R_2 = (I_L / 16\mu A_{RMS}) * RSH / 2$$

Where  $I_L$  = Line current

RSH = Shunt resistor/termination resistor

$R_3$ ,  $R_6$  and  $R_4$  set the current for the voltage sense input. The values should be selected so that the input current into the voltage sense input (virtual ground) is set to  $14\mu A_{RMS}$ .

$R_7$  defines all on-chip bias and reference currents. With  $R_7 = 24k\Omega$ , optimum conditions are set.

XTAL is a colour burst TV crystal ( $f = 3.5795MHz$ ) for the oscillator. The oscillator frequency is divided down to  $1.7897MHz$  on-chip to supply the A/D converters and digital circuitry.



**Figure 1: Application Circuit using a Shunt Resistor for current sensing, having a PC (Personal Computer) Interface.**

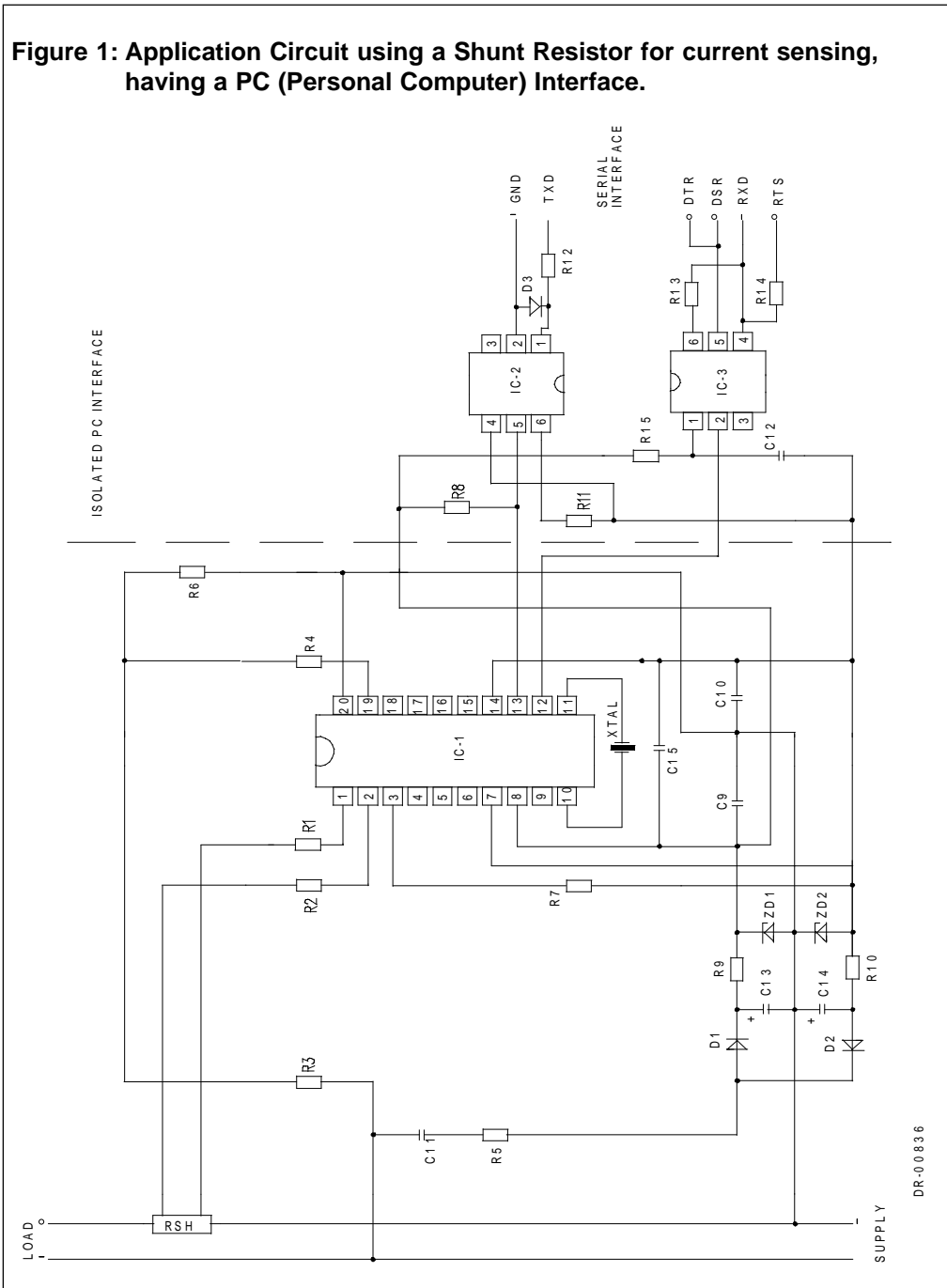

DR-00836

## SA9603C

### Part List for Application Circuit: Figure 1

Item	Symbol	Description	Detail
1	IC-1	SA9603C	DIP-20/SOIC-20
2	IC-2	Opto Coupler 4N35	DIP-6
3	IC-3	Opto Coupler 4N35	DIP-6
4	D1	Diode, Silicon, 1N4148	
5	D2	Diode, Silicon, 1N4148	
6	D3	Diode, Silicon, 1N4148	
7	ZD1	Diode, Zener, 2.4V, 200mW	
8	ZD2	Diode, Zener, 2.4V, 200mW	
9	XTAL	Crystal, 3.5795MHz	Colour burst TV
10	R1	Resistor, 1% metal	Note 1
11	R2	Resistor, 1% metal	Note 1
12	R3	Resistor, 390k, (230VAC), 1% metal	
13	R4	Resistor, 1M, 1/4W, 1% metal	
14	R5	Resistor, 470 $\Omega$ , 2W, 5%, carbon	
15	R6	Resistor, 24k, 1/4W, 1%, metal	
16	R7	Resistor, 24k, 1/4W, 1%, metal	
17	R8	Resistor, 680 $\Omega$ , 1/4W, 5%	
18	R9	Resistor, 680 $\Omega$ , 1/4W, 5%	
19	R10	Resistor, 680 $\Omega$ , 1/4W, 5%	
20	R11	Resistor, 100k, 1/4W, 5%	
21	R12	Resistor, 120 $\Omega$ , 1/4W, 5%	
22	R13	Resistor, 1/4W, 5%, 47k	
23	R14	Resistor, 1/4W, 5%, 1.6k	
24	R15	Resistor, 120 $\Omega$ , 1/4W, 5%	
25	C9	Capacitor, 100nF	
26	C10	Capacitor, 100nF	
27	C11	Capacitor, 0.47 $\mu$ F, 250VAC, polyester	
28	C12	Capacitor, 100nF	
29	C13	Capacitor, 100 $\mu$ F	
30	C14	Capacitor, 100 $\mu$ F	
31	C15	Capacitor, 820nF	
32	RSH	Shunt Resistor	Note 2

Note 1: Resistor (R1 and R2) values are dependant upon the selected value of RSH.

Note 2: See TYPICAL APPLICATIONS when selecting the value for RSH.



Figure 2: Application Circuit using a Current Transformer for current sensing.

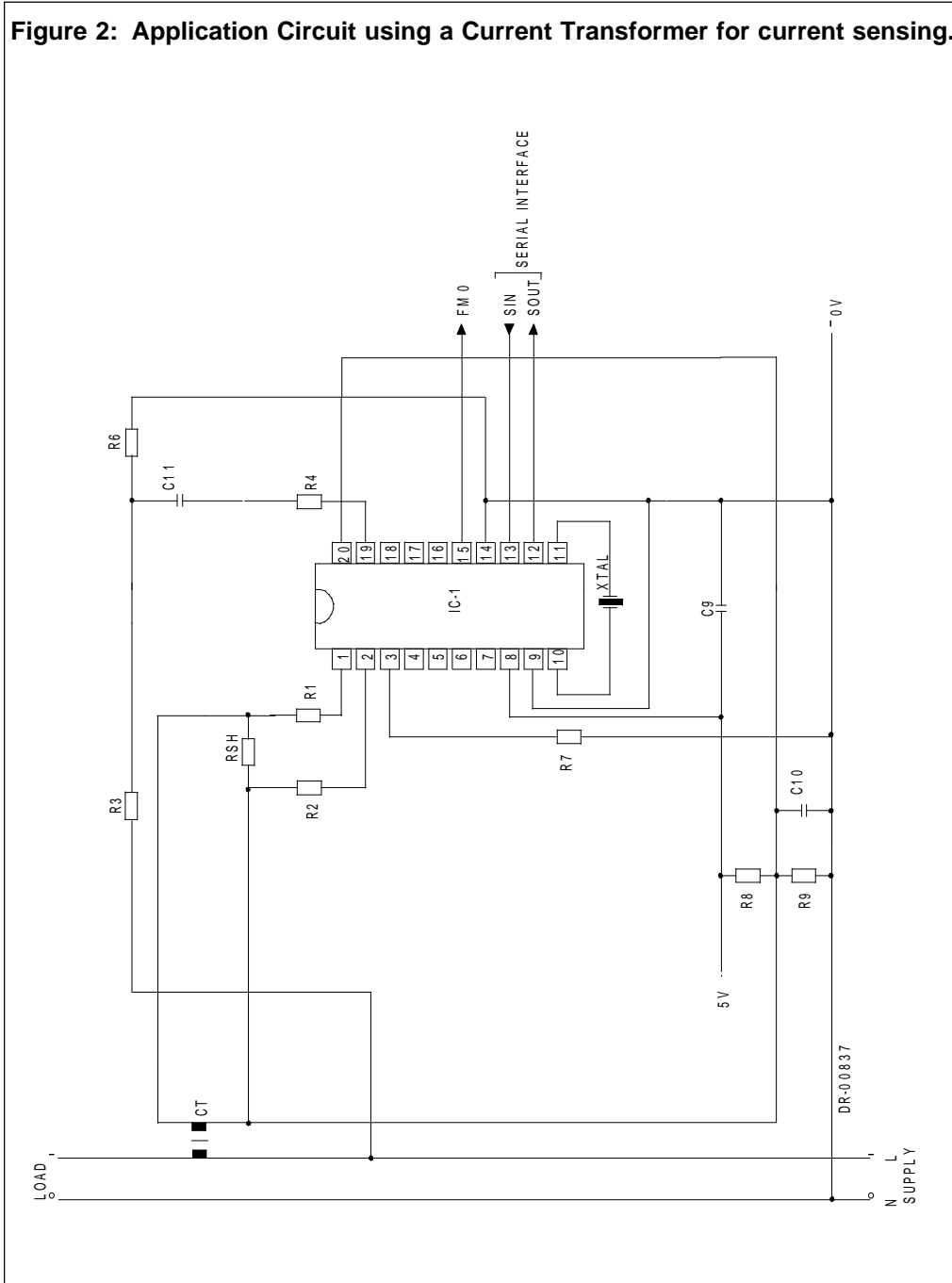

## SA9603C

---

### Parts List for Application Circuit: Figure 2

Item	Symbol	Description	Detail
1	IC-1	SA9603C	DIP-20/SOIC-20
2	XTAL	Crystal, 3.5795MHz	Colour burst TV
3	RSH	Resistor	Note 1
4	R1	Resistor, 1%, metal	Note 2
5	R2	Resistor, 1%, metal	Note 2
6	R3	Resistor, 390k, (230VAC) 1%, metal	
7	R4	Resistor, 1M, 1/4W, metal	
8	R6	Resistor, 24k, 1/4W, metal	
9	R7	Resistor, 24k, 1/4W, metal	
10	R8	Resistor, 2.2k, 1/4W, 5%	
11	R9	Resistor, 2.2k, 1/4W, 5%	
12	C9	Capacitor, 820nF	Note 3
13	C10	Capacitor, 100nF	
14	C11	Capacitor	Note 4
15	CT	Current Transformer	

Note 1: See TYPICAL APPLICATIONS when selecting the value of RSH.

Note 2: Resistor (R1 and R2) values are dependant upon the selected value of RSH.

Note 3: Capacitor (C9) to be positioned as close to IC-1, as possible.

Note 4: Capacitor (C11) selected for DC blocking and to minimize phase error introduced by the current transformer.

Part Number	Package
SA9603CPA	DIP-14
SA9603CPA	DIP-20
SA9603CSA	SOIC-20

Note: When ordering, the package option **must** be specified along with the part number.





**Note:**



## SA9603C

---

**Disclaimer:** The information contained in this document is confidential and proprietary to South African Micro-Electronic Systems (Pty) Ltd ("SAMES") and may not be copied or disclosed to a third party, in whole or in part, without the express written consent of SAMES. The information contained herein is current as of the date of publication; however, delivery of this document shall not under any circumstances create any implication that the information contained herein is correct as of any time subsequent to such date. SAMES does not undertake to inform any recipient of this document of any changes in the information contained herein, and SAMES expressly reserves the right to make changes in such information, without notification, even if such changes would render information contained herein inaccurate or incomplete. SAMES makes no representation or warranty that any circuit designed by reference to the information contained herein, will function without errors and as intended by the designer.

Any Sales or technical questions may be posted to our e-mail address below:  
[energy@sames.co.za](mailto:energy@sames.co.za)

For the latest updates on datasheets, please visit our web site:  
<http://www.sames.co.za>

### **South African Micro-Electronic Systems (Pty) Ltd**

P O Box 15888,  
Lynn East,  
0039  
Republic of South Africa,

33 Eland Street,  
Koedoespoort Industrial Area,  
Pretoria,  
Republic of South Africa

Tel: 012 333-6021  
Fax: 012 333-8071

Tel: Int +27 12 333-6021  
Fax: Int +27 12 333-8071

