

Small Signal Schottky diode

RB751S-40C2

Description

Planar silicon Schottky barrier diode encapsulated in a SOD-523 plastic SMD package.

Features

- Extremely small surface mounting type.(SC-79/SOD523)
- Low reverse current and low forward voltage
- High reliability

Applications

Low current rectification and high speed switching

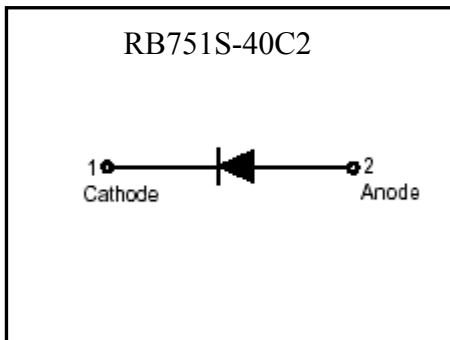
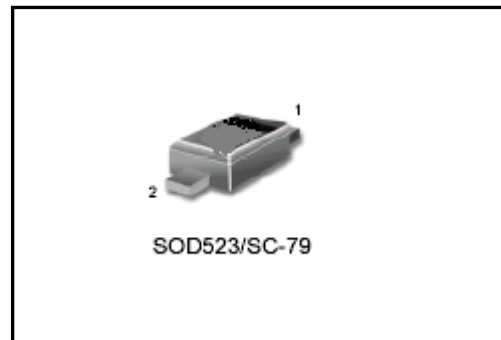
Symbol**Outline****Absolute Maximum Ratings**

- Maximum Temperatures
 - Storage Temperature T_{stg} -45~+125°C
 - Junction Temperature T_j +125°C
- Maximum Voltages and Currents ($T_a=25^\circ\text{C}$)
 - Peak Reverse Voltage V_{RM} 40 V
 - DC Reverse Voltage V_R 30 V
 - Mean Rectifying Current I_F 30 mA
 - Peak Forward Surge Current I_{FSM} 200 mA



Characteristics (Ta=25°C)

Characteristic	Symbol	Condition	Min.	Typ	Max.	Unit
Forward Voltage	V _F	I _F =1mA	-	-	370	mV
Reverse Leakage Current	I _R	V _R =30V	-	-	0.5	μA
Capacitance Between Terminals	C _T	V _R =1V, f=1MHz	-	2	-	pF

Characteristic Curves

Forward Current Derating Curve

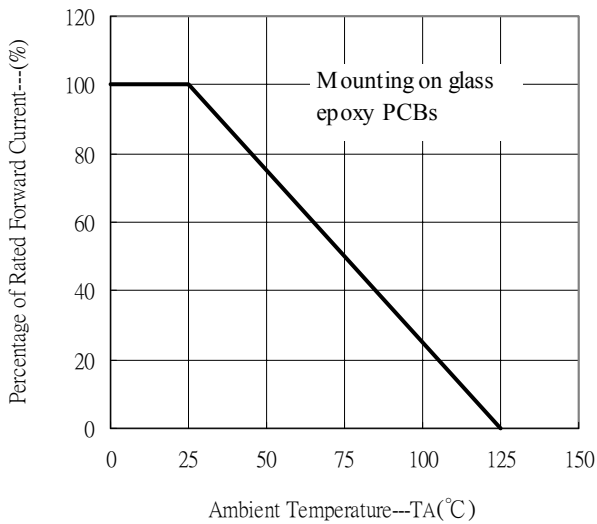

Forward Current vs Forward Voltage

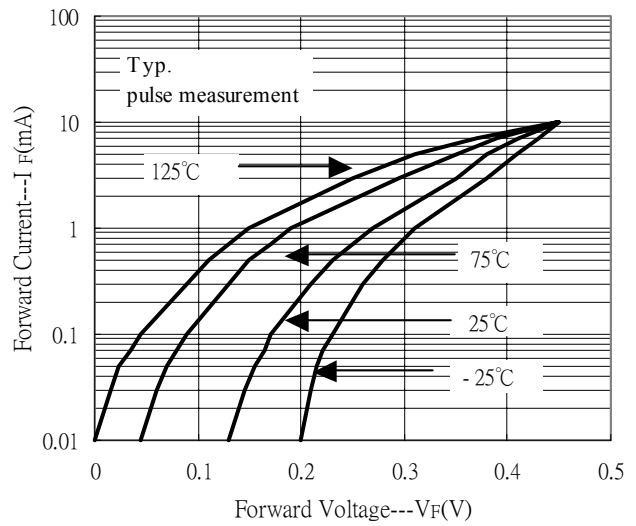

Reverse Leakage Current vs Reverse Voltage

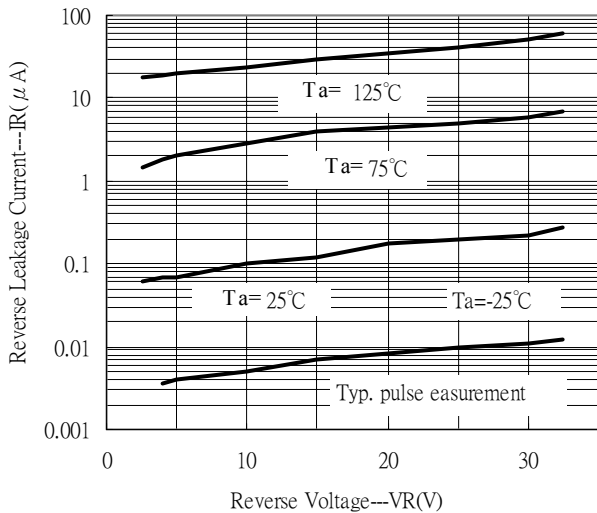

Capacitance vs Reverse Voltage

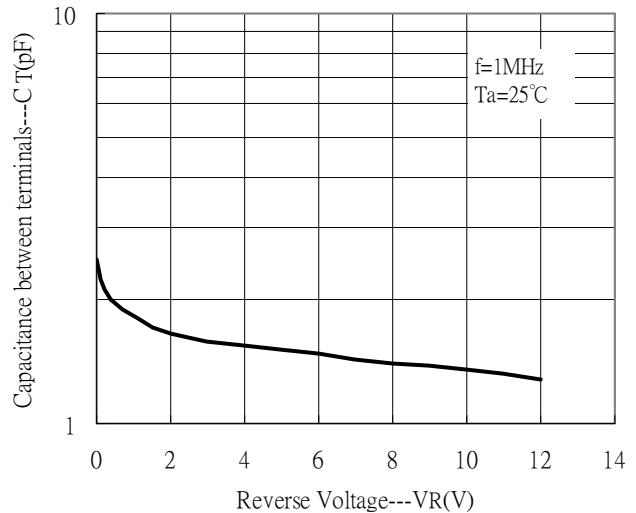

SOD-523 Dimension

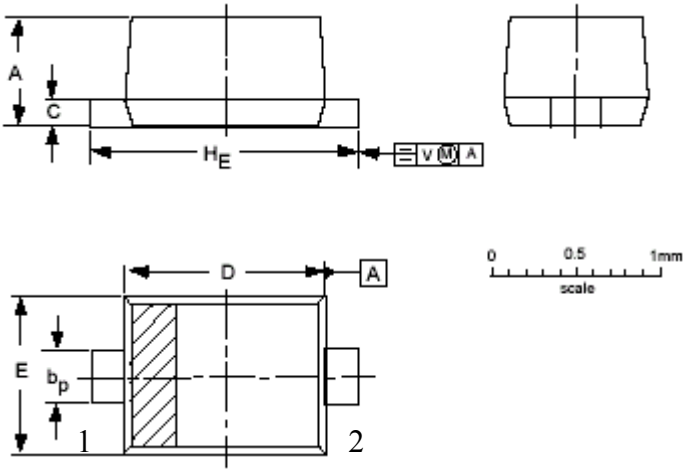

Marking Code :

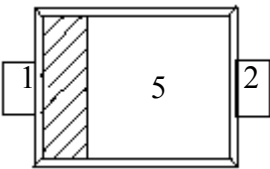

Style : Pin 1. Cathode 2. Anode

2-lead SOD-523 Plastic Package
 CYStek Package Code : C2

*: Typical

DIM	Millimeters		DIM	Millimeters	
	Min	.Max.		Min.	Max.
A	0.5	0.7	E	0.7	0.9
b _p	0.25	0.35	H _E	1.5	1.7
c	0.1	0.2	V	0.15(typ)	
D	1.1	1.3			

Notes: 1.Maximum lead thickness includes lead finish thickness, and minimum lead thickness is the minimum thickness of base material.
 2.If there is any question with packing specification or packing method, please contact your local CYStek sales office.

Material:

- Lead: 42 Alloy; solder plating
- Mold Compound: Epoxy resin family, flammability solid burning class: UL94V-0

Important Notice:

- All rights are reserved. Reproduction in whole or in part is prohibited without the prior written approval of CYStek.
- CYStek reserves the right to make changes to its products without notice.
- CYStek **semiconductor products are not warranted to be suitable for use in Life-Support Applications, or systems.**
- CYStek assumes no liability for any consequence of customer product design, infringement of patents, or application assistance.