

# PE9354

**SPDT High Power  
UltraCMOS™ RF Switch  
Rad hard for Space Applications**

### Features

- Single 3-volt power supply
- Low insertion loss: 0.55 dB at 2000 MHz
- High isolation of 30 dB at 2000 MHz
- Typical input 1 dB compression point of +31 dBm
- 100 Krad total dose
- Single-pin CMOS or TTL logic control
- Low cost

### Product Description

The PE9354 SPDT High Power UltraCMOS™ RF Switch is designed to cover a broad range of applications from near DC to 3000 MHz. This single-supply reflective switch integrates on-board CMOS control logic driven by a simple, single-pin CMOS and TTL compatible control input. Using a nominal +3-volt power supply, a typical input 1 dB compression point of +31 dBm can be achieved. The PE9354 also exhibits input-output isolation of better than 30 dB at 2000 MHz and is offered in a small 8-lead ceramic SOIC package.

The PE9354 is optimized for commercial space applications. Single Event Latch up (SEL) is physically impossible and Single Event Upset (SEU) is better than 10<sup>-9</sup> errors per bit/day. Fabricated in Peregrine's UltraCMOS™ technology, the PE9354 offers excellent RF performance and intrinsic radiation tolerance.

**Figure 1. Functional Schematic Diagram**

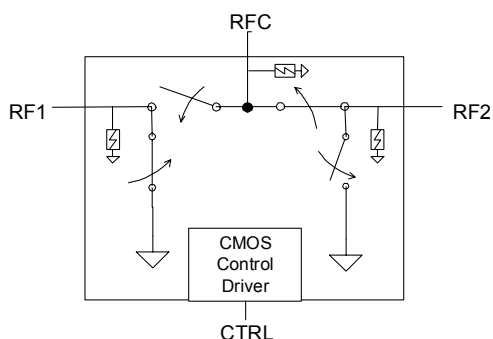

**Figure 2. Package Type**

8-lead CSOIC

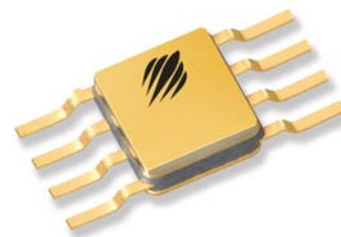
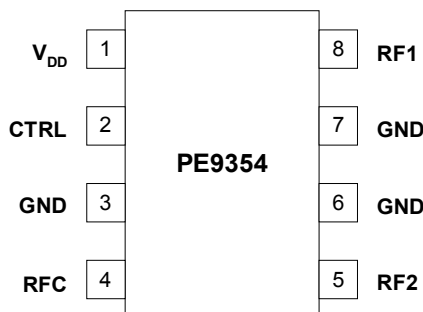

**Table 1. A/C Electrical Specifications -55 °C to +125 °C, V<sub>DD</sub> = 3.0 V (Z<sub>s</sub> = Z<sub>L</sub> = 50 Ω)**

Parameter	Conditions	Minimum	Typical	Maximum	Units
Operation Frequency <sup>1</sup>		DC		3000	MHz
Insertion Loss	2000 MHz		0.55	0.80	dB
Isolation – RFC to RF1/RF2	2000 MHz	28	32		dB
Isolation – RF1 to RF2	2000 MHz	24	28		dB
Return Loss <sup>2</sup>	2000 MHz		22		dB
Input 1 dB Compression	2000 MHz	28	31		dBm

Note: 1. Device linearity will begin to degrade below 10 MHz.

Note: 2. Return loss not measured in production due to equipment limitations

**Figure 3. Pin Configuration**

**Table 2. Pin Descriptions**

Pin No.	Pin Name	Description
1	V <sub>DD</sub>	Nominal +3V supply connection.
2	CTRL	CMOS or TTL logic level: High = RFC to RF1 signal path Low = RFC to RF2 signal path
3	GND	Ground connection. Traces should be physically short and connected to ground plane for best performance.
4	RFC	Common RF port for switch. <sup>1</sup>
5	RF2	RF2 port. <sup>1</sup>
6	GND	Ground Connection. Traces should be physically short and connected to ground plane for best performance.
7	GND	Ground Connection. Traces should be physically short and connected to ground plane for best performance.
8	RF1	RF1 port. <sup>1</sup>

Note 1: All RF pins must be DC blocked with an external series capacitor or held at 0 V<sub>DC</sub>.

**Table 4. DC Electrical Specifications**

Parameter	Min	Typ	Max	Units
V <sub>DD</sub> Power Supply Voltage	2.7	3.0	3.3	V
Input Leakage	-1		1	μA
I <sub>DD</sub> Power Supply Current (V <sub>DD</sub> = 3V, V <sub>CTRL</sub> = 3V)		28	100	μA
Control Voltage High	0.7xV <sub>DD</sub>			V
Control Voltage Low			0.3xV <sub>DD</sub>	V

**Table 3. Absolute Maximum Ratings**

Symbol	Parameter/Conditions	Min	Max	Units
V <sub>DD</sub>	Power supply voltage	-0.3	4.0	V
V <sub>I</sub>	Voltage on any input except for the CTRL input	-0.3	V <sub>DD</sub> +0.3	V
V <sub>CTRL</sub>	Voltage on CTRL input		5.0	V
T <sub>ST</sub>	Storage temperature range	-65	150	°C
T <sub>OP</sub>	Operating temperature range	-55	125	°C
P <sub>IN</sub>	Input power (50 Ω)		32	dBm
V <sub>ESD</sub>	ESD voltage (Human Body Model)		200	V
Total Dose	Total Cumulative Exposure to Ionizing Radiation		100k	Rads (Si)

Absolute Maximum Ratings are those values listed in the above table. Exceeding these values may cause permanent device damage. Functional operation should be restricted to the limits in the DC Electrical Specifications table. Exposure to absolute maximum ratings for extended periods may affect device reliability.

### Electrostatic Discharge (ESD) Precautions

When handling this UltraCMOS™ device, observe the same precautions that you would use with other ESD-sensitive devices. Although this device contains circuitry to protect it from damage due to ESD, precautions should be taken to avoid exceeding the rating specified in Table 3.

### Latch-Up Avoidance

Unlike conventional CMOS devices, UltraCMOS™ devices are immune to latch-up.

**Table 5. Control Logic Truth Table**

Control Voltage	Signal Path
CTRL = CMOS or TTL High	RFC to RF1
CTRL = CMOS or TTL Low	RFC to RF2

The control logic input pin (CTRL) is typically driven by a 3-volt CMOS logic level signal, and has a threshold of 50% of V<sub>DD</sub>. For flexibility to support systems that have 5-volt control logic drivers, the control logic input has been designed to handle a 5-volt logic HIGH signal. (A minimal current will be sourced out of the V<sub>DD</sub> pin when the control logic input voltage level exceeds V<sub>DD</sub>.)

Typical Performance Data @ -55 °C to 125 °C

Figure 4. Insertion Loss – RFC to RF1

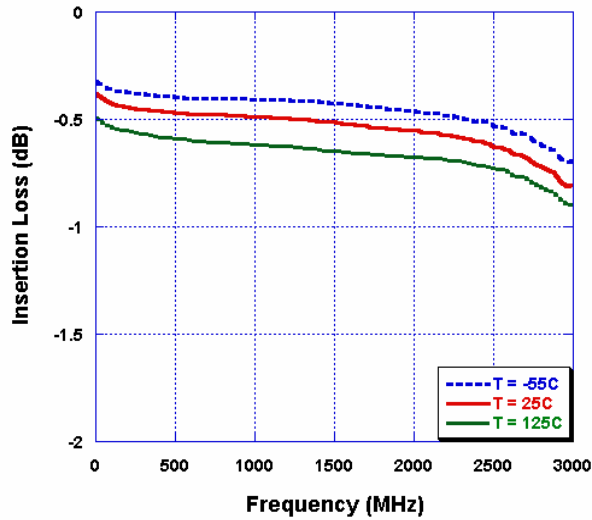

Figure 5. Input 1dB Compression Point

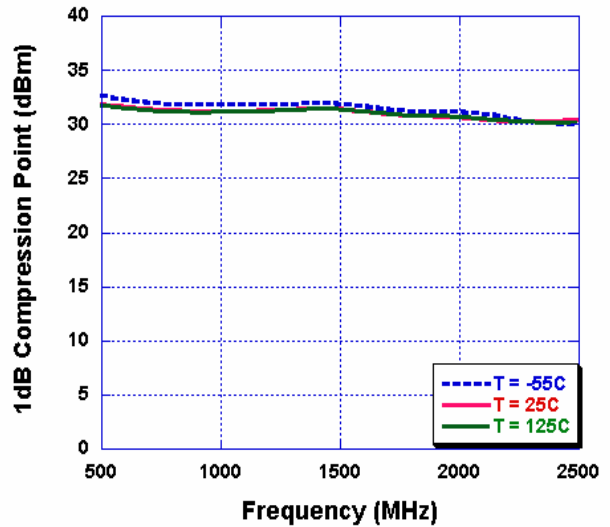

Figure 6. Insertion Loss – RFC to RF2

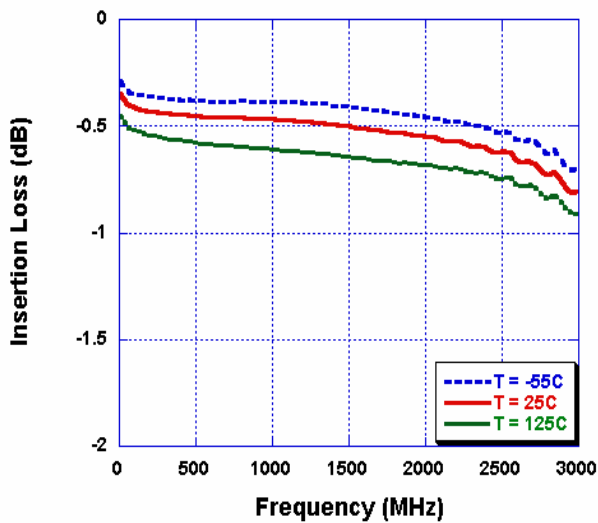
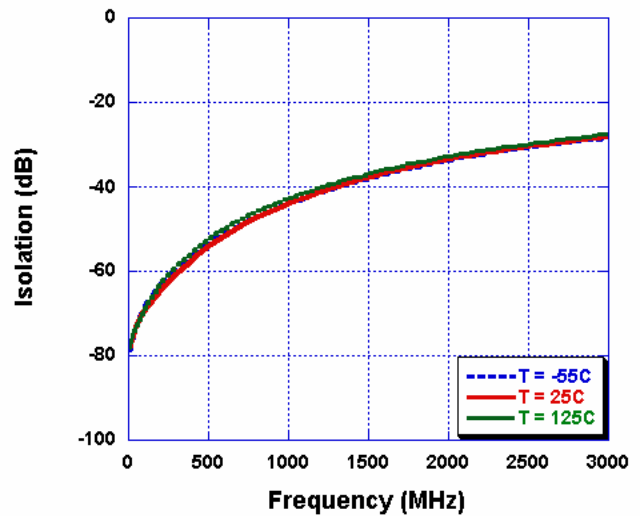

Figure 7. Isolation – RFC to RF1



Typical Performance Data @ -55 °C to 125 °C

Figure 8. Isolation – RFC to RF2

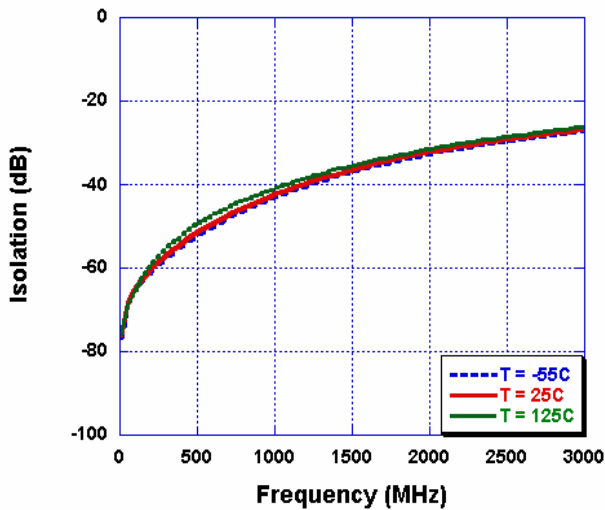

Figure 9. Isolation – RF1/RF2 to RF2/RF1

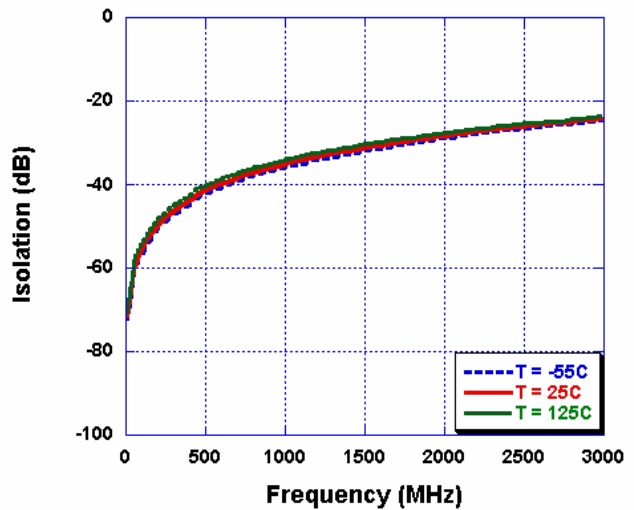

Figure 10. Return Loss – RFC

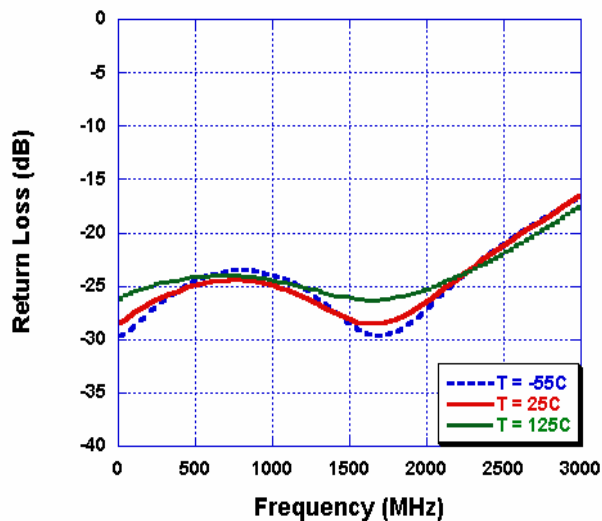
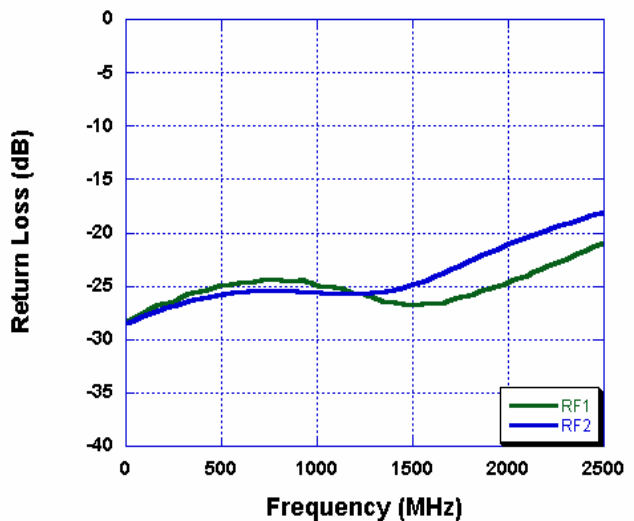

Figure 11. Return Loss – RF1, RF2



## Evaluation Kit Information

### Evaluation Kit

The SPDT Switch Evaluation Kit board was designed to ease customer evaluation of the PE9354 SPDT switch. The RF common port is connected through a 50 Ω transmission line to the top left SMA connector, J1. Port 1 and Port 2 are connected through 50 Ω transmission lines to the top two SMA connectors on the right side of the board, J2 and J3. A through transmission line connects SMA connectors J4 and J5. This transmission line can be used to estimate the loss of the PCB over the environmental conditions being evaluated.

The board is constructed of a two metal layer FR4 material with a total thickness of 0.031". The bottom layer provides ground for the RF transmission lines. The transmission lines were designed using a coplanar waveguide with ground plane model using a trace width of 0.030", trace gaps of 0.007", dielectric thickness of 0.028", metal thickness of 0.0014" and  $\epsilon_r$  of 4.4.

J6 provides a means for controlling DC and digital inputs to the device. Starting from the lower left pin, the second pin to the right (J2-3) is connected to the device CNTL input. The fourth pin to the right (J2-7) is connected to the device V<sub>DD</sub> input. A decoupling capacitor (100 pF) is provided on both CTRL and V<sub>DD</sub> traces. It is the responsibility of the customer to determine proper supply decoupling for their design application. Removing these components from the evaluation board has not been shown to degrade RF performance.

The ground plane has been removed from beneath the device for performance issues. It was found that insertion loss dips (suck-outs) were experienced due to the capacitive effect of the metal package sitting insulated by the solder-mask on the ground plane. All

**Figure 12. Evaluation Board Layouts**

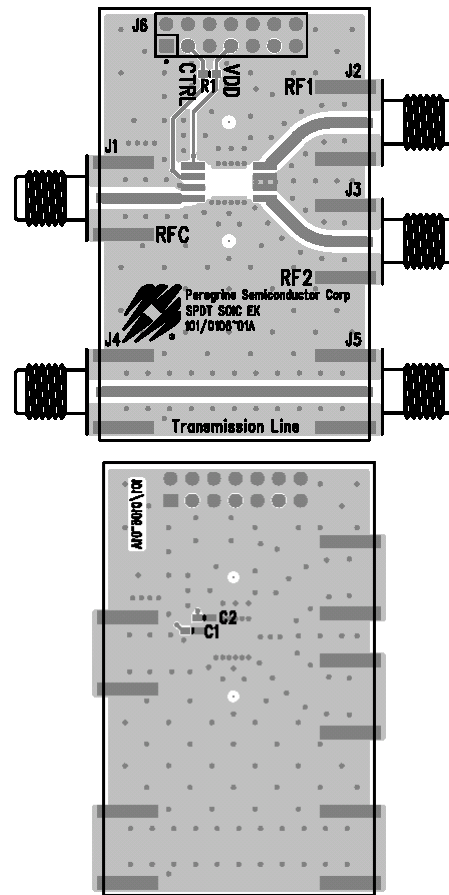

data specified and shown on this datasheet was taken using this evaluation board configuration. For optimal performance, the package may be soldered directly to the ground plane, but the reliability issues associated with this mounting must be addressed by the customer.

**Figure 13. Evaluation Board Schematic**  
Peregrine specification 102/0129

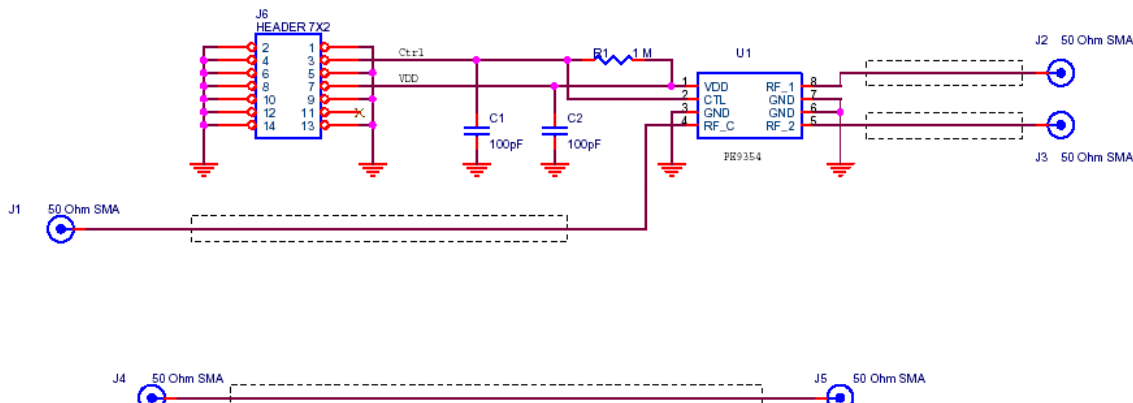

**Figure 14. Package Drawing**

8-lead CSOIC

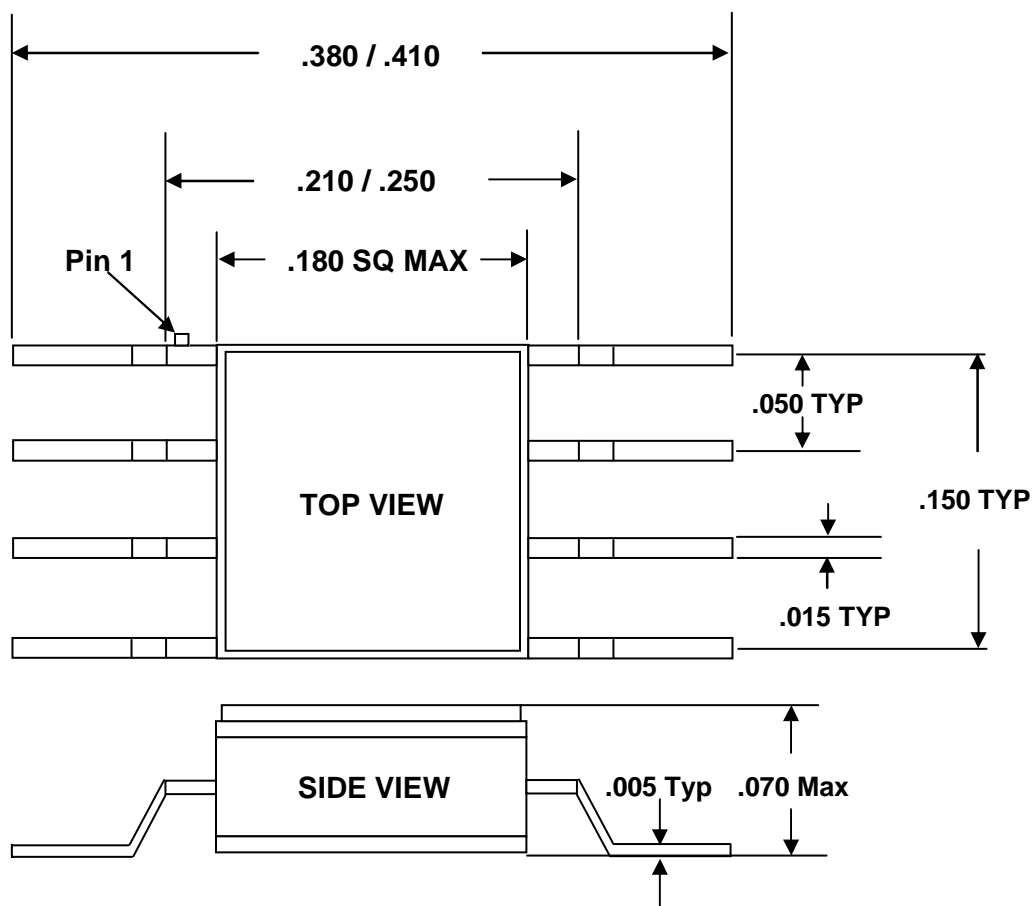

**Table 6. Ordering Information**

Order Code	Part Marking	Description	Package	Shipping Method
9354-01	PE9354 ES	Engineering Samples	8-lead Ceramic SOIC	50 units / Tray
9354-11	PE9354	Flight Units	8-lead Ceramic SOIC	50 units / Tray
9354-00	PE9354-EK	PE9354 Evaluation Kit	Evaluation Kit	1 / Box

## Sales Offices

### *The Americas*

#### **Peregrine Semiconductor Corporation**

9450 Carroll Park Drive  
San Diego, CA 92121  
Tel: 858-731-9400  
Fax: 858-731-9499

### *Europe*

#### **Peregrine Semiconductor Europe**

Bâtiment Maine  
13-15 rue des Quatre Vents  
F-92380 Garches, France  
Tel: +33-1-47-41-91-73  
Fax : +33-1-47-41-91-73

### **Space and Defense Products**

#### **Americas:**

Tel: 858-731-9453

#### **Europe, Asia Pacific:**

180 Rue Jean de Guiramand  
13852 Aix-En-Provence Cedex 3, France  
Tel: +33(0) 4 4239 3361  
Fax: +33(0) 4 4239 7227

### *North Asia Pacific*

#### **Peregrine Semiconductor K.K.**

Teikoku Hotel Tower 10B-6  
1-1-1 Uchisaiwai-cho, Chiyoda-ku  
Tokyo 100-0011 Japan  
Tel: +81-3-3502-5211  
Fax: +81-3-3502-5213

#### **Peregrine Semiconductor, Korea**

#B-2402, Kolon Tripolis, #210  
Geumgok-dong, Bundang-gu, Seongnam-si  
Gyeonggi-do, 463-480 S. Korea  
Tel: +82-31-728-4300  
Fax: +82-31-728-4305

### *South Asia Pacific*

#### **Peregrine Semiconductor, China**

Shanghai, 200040, P.R. China  
Tel: +86-21-5836-8276  
Fax: +86-21-5836-7652

For a list of representatives in your area, please refer to our Web site at: [www.psemi.com](http://www.psemi.com)

## Data Sheet Identification

### **Advance Information**

The product is in a formative or design stage. The data sheet contains design target specifications for product development. Specifications and features may change in any manner without notice.

### **Preliminary Specification**

The data sheet contains preliminary data. Additional data may be added at a later date. Peregrine reserves the right to change specifications at any time without notice in order to supply the best possible product.

### **Product Specification**

The data sheet contains final data. In the event Peregrine decides to change the specifications, Peregrine will notify customers of the intended changes by issuing a DCN (Document Change Notice).

The information in this data sheet is believed to be reliable. However, Peregrine assumes no liability for the use of this information. Use shall be entirely at the user's own risk.

No patent rights or licenses to any circuits described in this data sheet are implied or granted to any third party.

Peregrine's products are not designed or intended for use in devices or systems intended for surgical implant, or in other applications intended to support or sustain life, or in any application in which the failure of the Peregrine product could create a situation in which personal injury or death might occur. Peregrine assumes no liability for damages, including consequential or incidental damages, arising out of the use of its products in such applications.

The Peregrine name, logo, and UTSi are registered trademarks and UltraCMOS and HaRP are trademarks of Peregrine Semiconductor Corp.