

P 5A

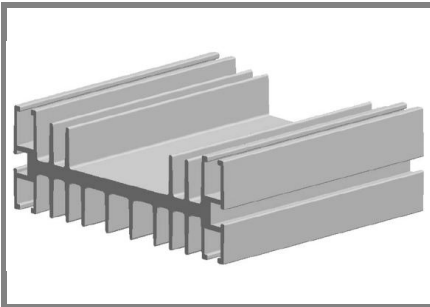

Heatsink

Standard lengths	n	b / d Ø mm	R _{thha} natural cooling K/W	R _{thha} K/W	w kg
P 5A/100			1,7 (35 W) 1,55 (40 W) 1,5 (40 W) 1,5 (40 W) 1,45 (45 W)	with SKB 15 with SKB 25, SKD 25 with SKB 30, SKD 30 with SEMIPONT 1 with SEMIPONT 2	0,28

For bridge modules

P 5A

Features

- Intended for bridge rectifier modules
- Designed for natural air cooling
- Available in various lengths

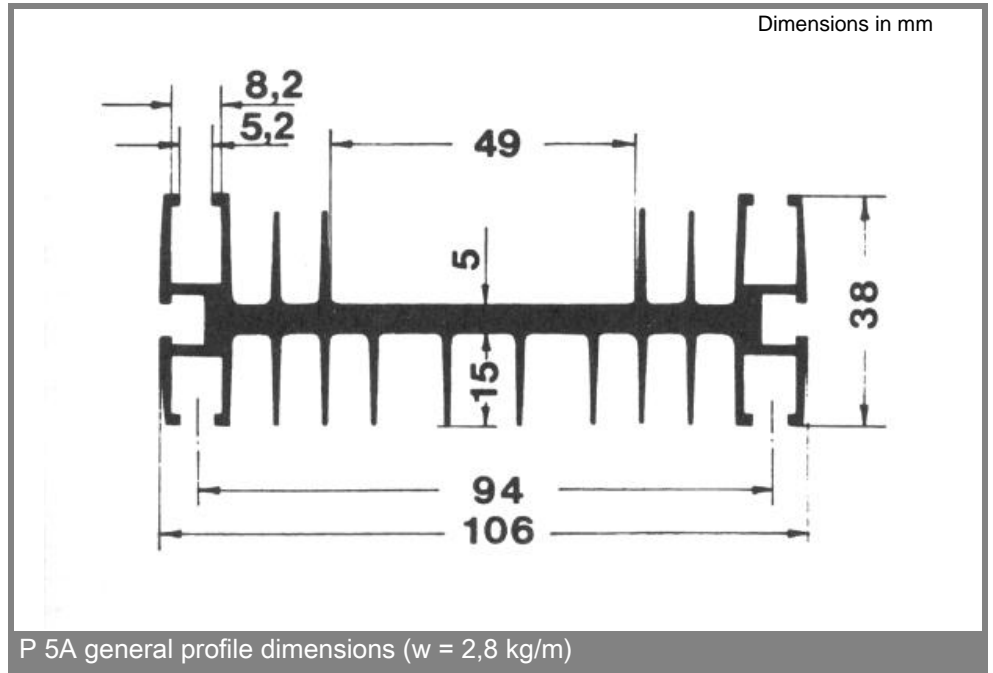

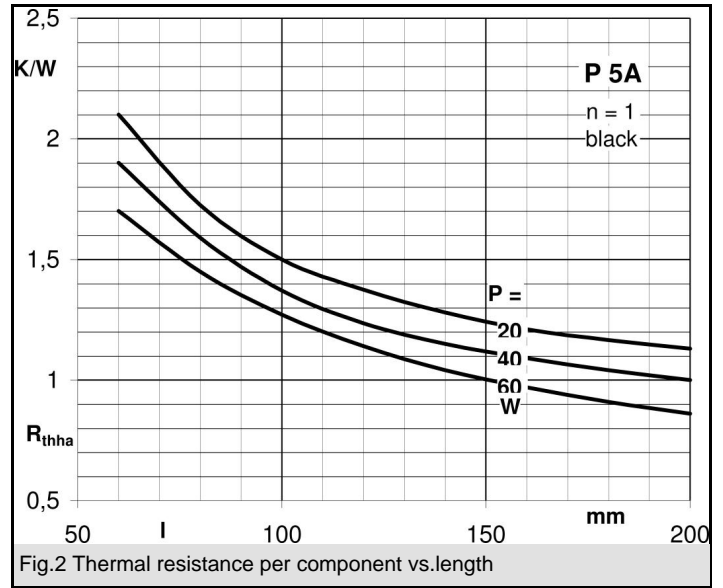
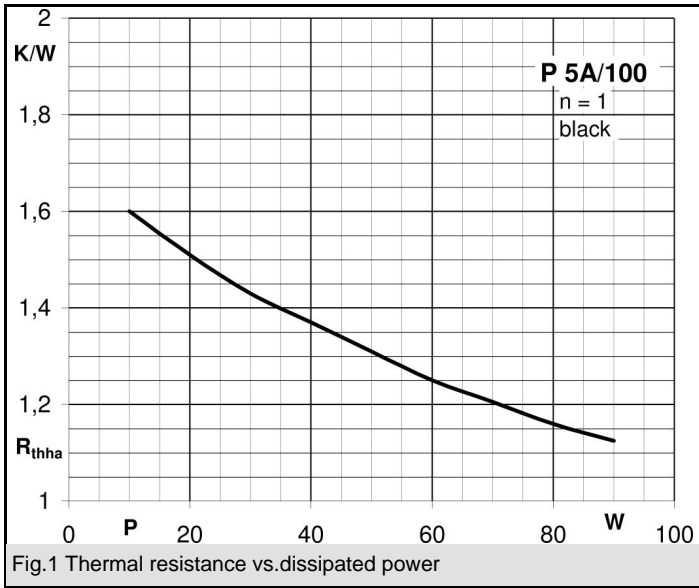

P5A/100

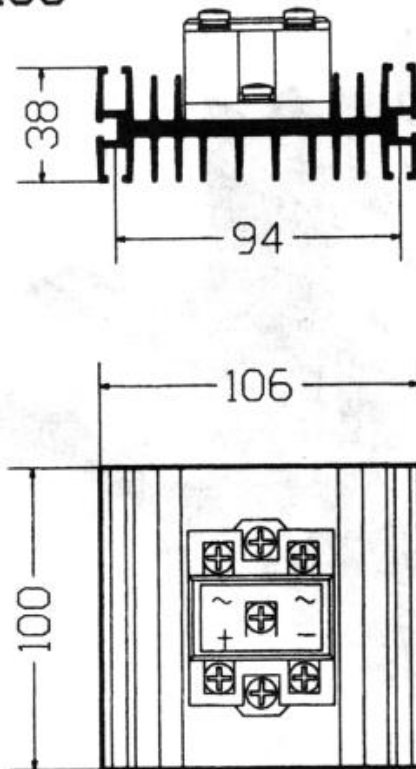

1. Application example using a SEMIPONT bridge module and heatsink P 5A/100 to give single phase bridge rectifier