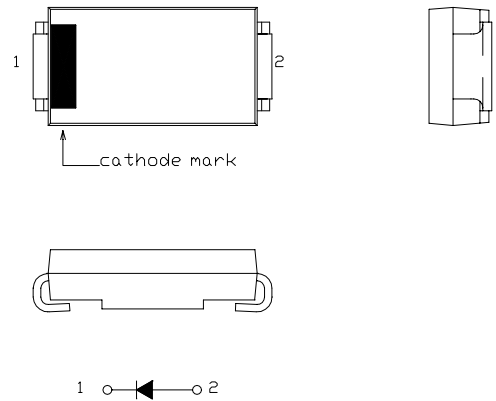

OUTLINE DRAWING

FRD Type : NSF03A60
FEATURES

- * **FLAT-PAK** Surface Mount Device
- * Ultra F_{sat} Recovery
- * High Surge Capability
- * Low Forward Voltage Drop
- * Low Power Loss, High Efficiency
- * Packaged in 16mm Tape and Reel
- * Not Rolling During Assembly

Maximum Ratings

Approx Net Weight:016g

Rating	Symbol	NSF03A60		Unit
Repetitive Peak Reverse Voltage	V_{RRM}	600		V
Average Rectified Output Current	I_O	1.1	Ta=27 °C *1	50Hz Half Sine Wave Resistive Load
		3.0	T1=79 °C *2	
RMS Forward Current	$I_{F(RMS)}$	4.71		A
Surge Forward Current	I_{FSM}	45	50Hz Half Sine Wave, 1cycle Non-repetitive	A
Operating Junction Temperature Range	T_{jw}	-40 to +150		°C
Storage Temperature Range	T_{stg}	-40 to +150		°C

Electrical • Thermal Characteristics

Characteristics	Symbol	Conditions	Min.	Typ.	Max.	Unit
Peak Reverse Current	I_{RM}	T _j = 25°C, V _{RM} = V _{RRM}	-	-	20	μA
Peak Forward Voltage	V _{FM}	T _j = 25°C, I _{FM} = 3.0A	-	-	1.7	V
Reverse Recovery Time	trr	Ta= 25°C, I _{FM} =3 A -di/dt=50A/μs	-	-	35	ns
Thermal Resistance	R _{th(j-a)}	Junction to Ambient *1	-	-	89	°C /W
	R _{th(j-l)}	Junction to Lead	-	-	13	

*1 Alumina Substrate Mounted (Soldering Lands=2x3.5mm,Both Sides)

*2 Tl= Lead Temperature

NSF03A60 OUTLINE DRAWING (Dimensions in mm)

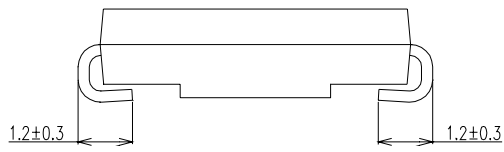
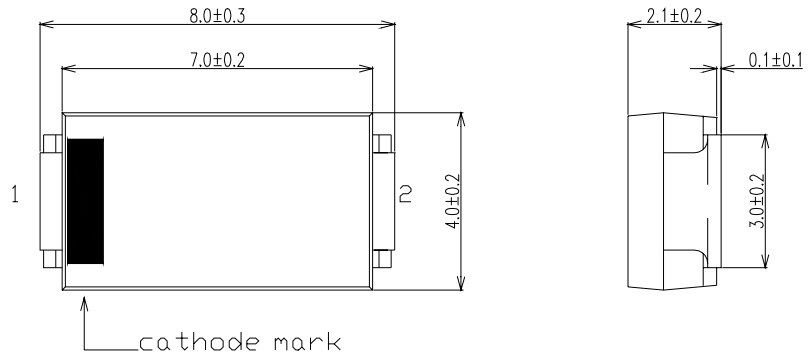

SOLDERING PAD

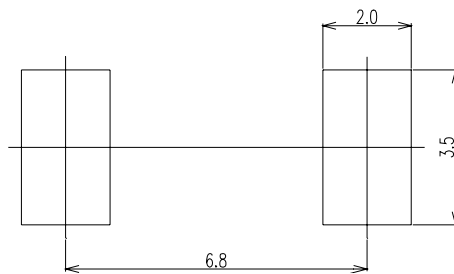

FORWARD CURRENT VS. VOLTAGE

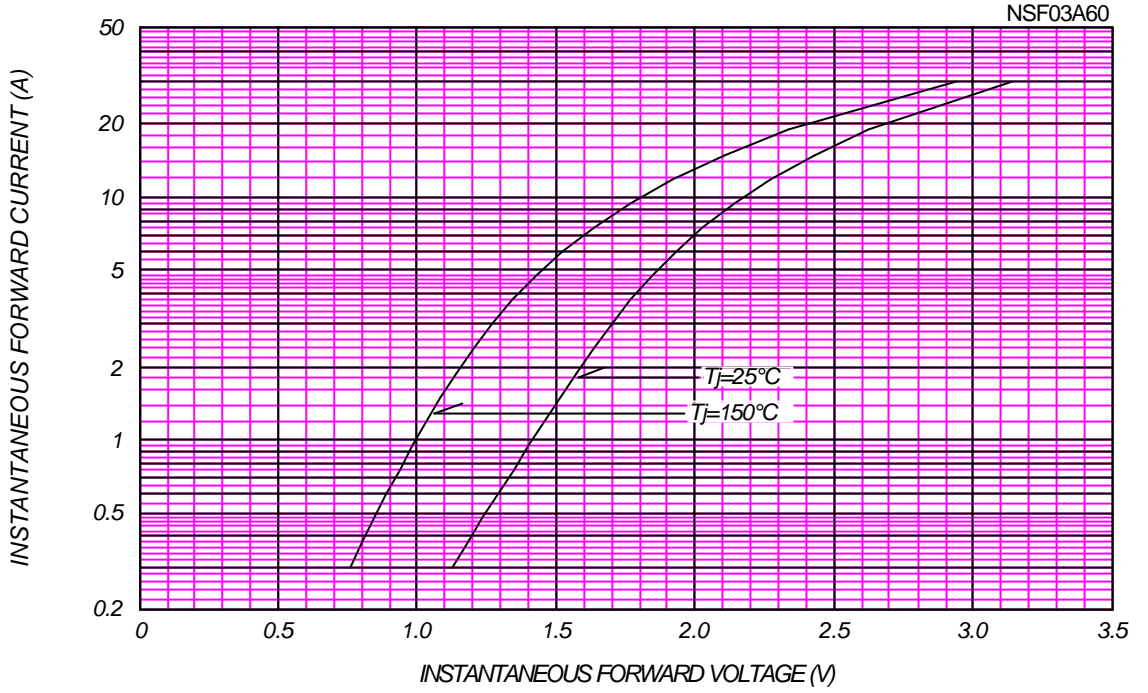

AVERAGE FORWARD POWER DISSIPATION

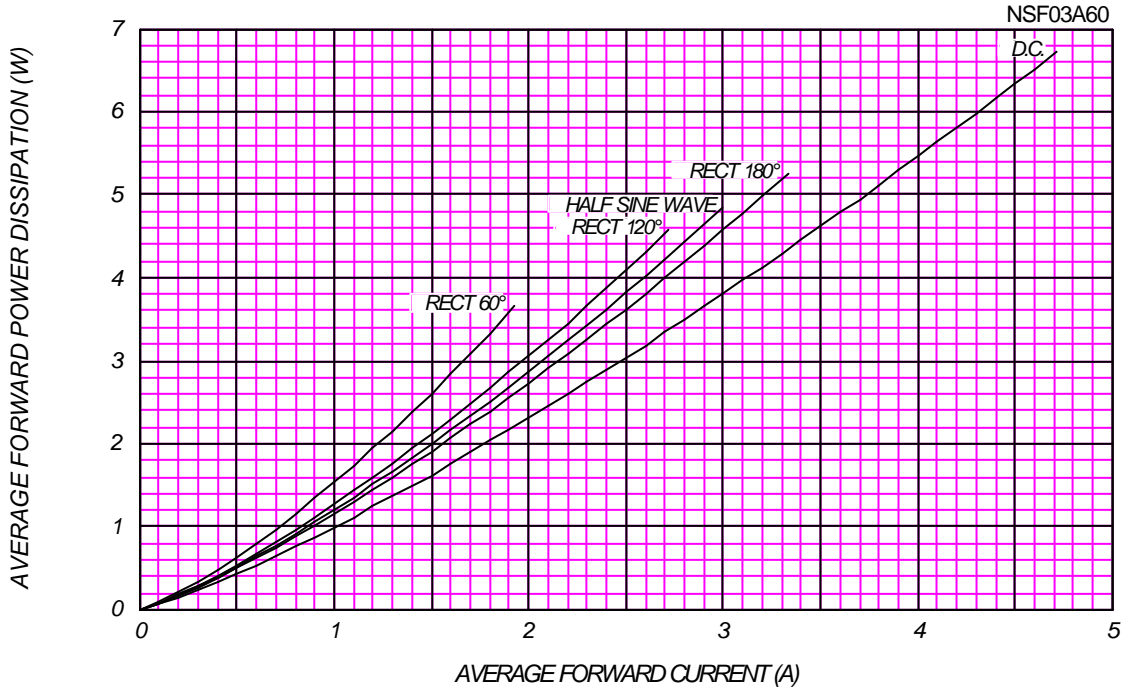



AVERAGE FORWARD CURRENT VS. AMBIENT TEMPERATURE

Alumina Substrate Mounted (Soldering Land=2x3.5mm)

NSF03A60

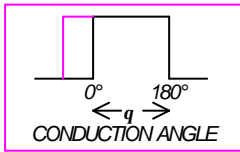
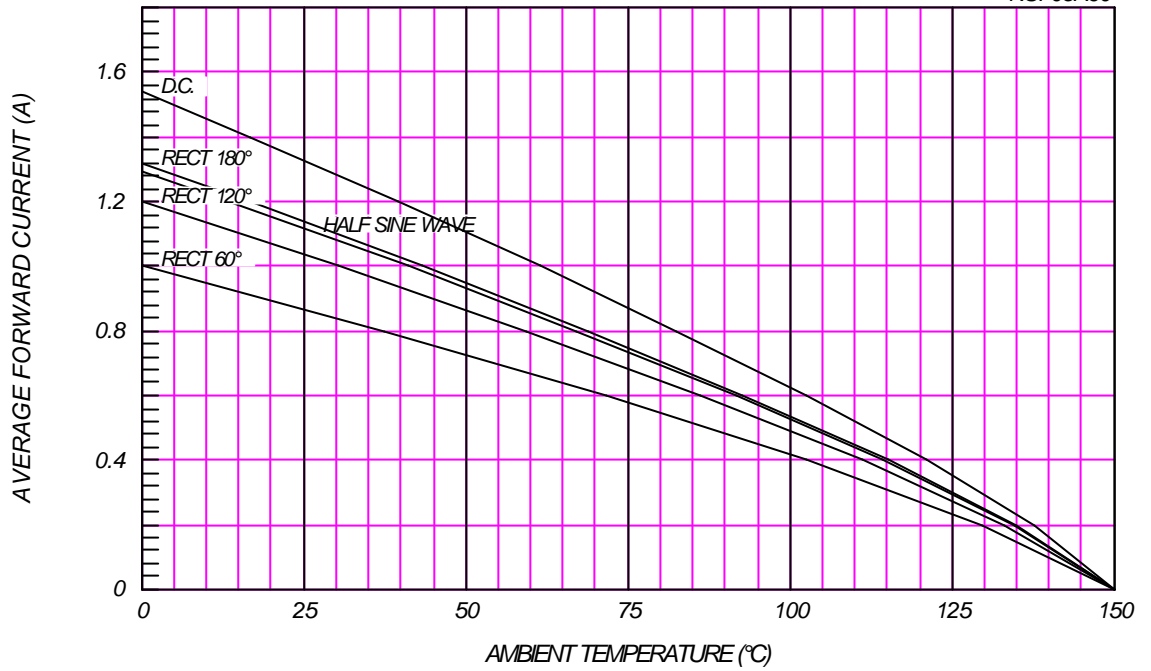

AVERAGE FORWARD CURRENT VS. LEAD TEMPERATURE

NSF03A60

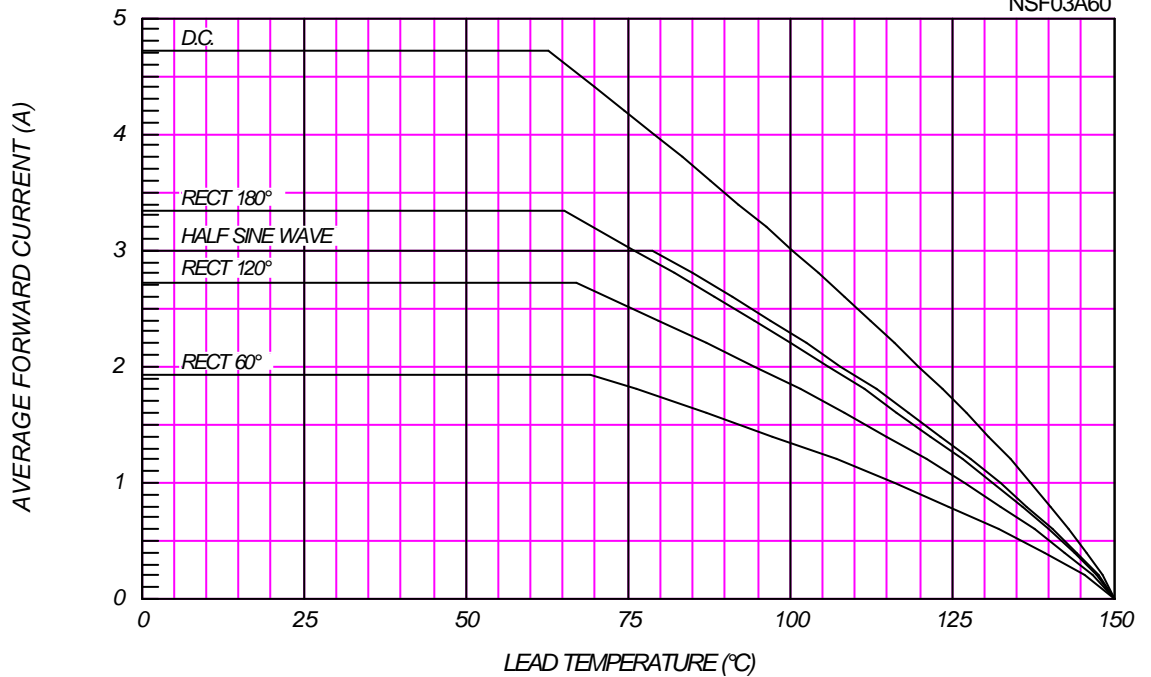

SURGE CURRENT RATINGS

f=50Hz, Half Sine Wave, Non-Repetitive, No Load

NSF03A60

