

NLASB3157

SPDT, 3 Ω R_{ON} Switch

The NLASB3157 is an advanced CMOS analog switch fabricated with silicon gate CMOS technology. It achieves very low propagation delay and $R_{DS_{ON}}$ resistances while maintaining CMOS low power dissipation. Analog and digital voltages that may vary across the full power-supply range (from V_{CC} to GND). This device is a drop in replacement for the NC7SB3157.

The select pin has overvoltage protection that allows voltages above V_{CC} , up to 7.0 V to be present on the pin without damage or disruption of operation of the part, regardless of the operating voltage.

Features

- High Speed: $t_{PD} = 1.0$ ns (Typ) at $V_{CC} = 5.0$ V
- Low Power Dissipation: $I_{CC} = 2.0$ μ A (Max) at $T_A = 25^\circ$ C
- Standard CMOS Logic Levels
- High Bandwidth, Improved Linearity
- Switches Standard NTSC/PAL Video, Audio, SPDIF and HDTV
- May be used for Clock Switching, Data Multiplexing, etc.
- R_{ON} Typical = 3 Ω @ $V_{CC} = 4.5$ V
- Break Before Make Circuitry, Prevents Inadvertent Shorts
- 2 Devices can Switch Balanced Signal Pairs, e.g. LVDS > 200-Mb/s
- Latchup Performance Exceeds 300 mA
- Pin for Pin Drop in for NC7SB3157
- Tiny SC88 and WDFN6 Packages
- ESD Performance:
 - ◆ Human Body Model; > 2000 V;
 - ◆ Machine Model; > 200 V
- Extended Automotive Temperature Range -55° C to $+125^\circ$ C (See Appendix)
- Pb-Free Packages are Available



ON Semiconductor®

<http://onsemi.com>

MARKING DIAGRAMS



SC-88
DF SUFFIX
CASE 419B

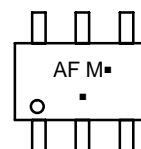

WDFN6
MT SUFFIX
CASE 506AS



AF, F = Specific Device Code
M = Date Code*
▪ = Pb-Free Package

(Note: Microdot may be in either location)
*Date Code orientation may vary depending upon manufacturing location.

FUNCTION TABLE

Select Input	Function
L	B0 Connected to A
H	B1 Connected to A

ORDERING INFORMATION

Device	Package	Shipping†
NLASB3157DFT2	SC-88	3000 Tape & Reel
NLASB3157DFT2G	SC-88 (Pb-Free)	3000 Tape & Reel
NLASB3157MTR2G	WDFN6 (Pb-Free)	3000 Tape & Reel

†For information on tape and reel specifications, including part orientation and tape sizes, please refer to our Tape and Reel Packaging Specifications Brochure, BRD8011/D.

NLASB3157

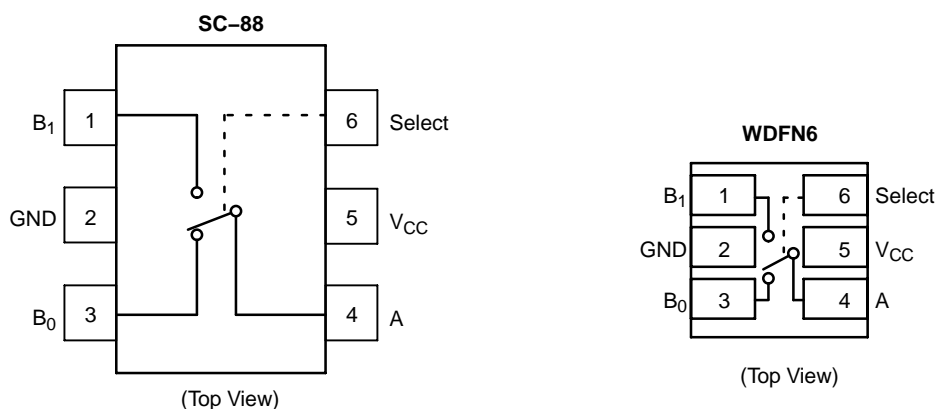

Figure 1. Pin Assignment & Logic Diagram

MAXIMUM RATINGS

Rating	Symbol	Value	Unit
Supply Voltage	V_{CC}	-0.5 to +7.0	V
DC Switch Voltage (Note 1)	V_S	-0.5 to $V_{CC} + 0.5$	V
DC Input Voltage (Note 1)	V_{IN}	-0.5 to +7.0	V
DC Input Diode Current @ $V_{IN} < 0$ V	I_{IK}	-50	mA
DC Output Current	I_{OUT}	128	mA
DC V_{CC} or Ground Current	I_{CC}/I_{GND}	+100	mA
Storage Temperature Range	T_{stg}	-65 to +150	°C
Junction Temperature Under Bias	T_J	150	°C
Junction Lead Temperature (Soldering, 10 Seconds)	T_L	260	°C
Power Dissipation @ +85°C	P_D	180	mW

Stresses exceeding Maximum Ratings may damage the device. Maximum Ratings are stress ratings only. Functional operation above the Recommended Operating Conditions is not implied. Extended exposure to stresses above the Recommended Operating Conditions may affect device reliability.

1. The input and output negative voltage ratings may be exceeded if the input and output diode current ratings are observed.

RECOMMENDED OPERATING CONDITIONS (Note 2)

Characteristic	Symbol	Min	Max	Unit
Supply Voltage Operating	V_{CC}	1.65	5.5	V
Select Input Voltage	V_{IN}	0	V_{CC}	V
Switch Input Voltage	V_{IN}	0	V_{CC}	V
Output Voltage	V_{OUT}	0	V_{CC}	V
Operating Temperature	T_A	-55	+125	°C
Input Rise and Fall Time Control Input $V_{CC} = 2.3$ V–3.6 V Control Input $V_{CC} = 4.5$ V–5.5 V	t_r, t_f	0	10 5.0	ns/V
Thermal Resistance	θ_{JA}	-	350	°C/W

2. Select input must be held HIGH or LOW, it must not float.

DC ELECTRICAL CHARACTERISTICS

Symbol	Parameter	Test Conditions	V _{CC} (V)	T _A = +25°C			T _A = -40°C to +85°C		Unit
				Min	Typ	Max	Min	Max	
V _{IH}	HIGH Level Input Voltage		1.65–1.95 2.3–5.5				0.75 V _{CC} 0.7 V _{CC}		V
V _{IL}	LOW Level Input Voltage		1.65–1.95 2.3–5.5					0.25 V _{CC} 0.3 V _{CC}	V
I _{IN}	Input Leakage Current	0 ≤ V _{IN} ≤ 5.5 V	0–5.5		±0.05	±0.1		±1	μA
I _{OFF}	OFF State Leakage Current	0 ≤ A, B ≤ V _{CC}	1.65–5.5		±0.05	±0.1		±1	μA
R _{ON}	Switch On Resistance (Note 3)	V _{IN} = 0 V, I _O = 30 mA	4.5		3.0			7.0	Ω
		V _{IN} = 2.4 V, I _O = -30 mA			5.0			12	
		V _{IN} = 4.5 V, I _O = -30 mA			7.0			15	
		V _{IN} = 0 V, I _O = 24 mA	3.0		4.0			9.0	
		V _{IN} = 3 V, I _O = -24 mA			10			20	Ω
		V _{IN} = 0 V, I _O = 8 mA	2.3		5.0			12	Ω
		V _{IN} = 2.3 V, I _O = -8 mA			13			30	
		V _{IN} = 0 V, I _O = 4 mA	1.65		6.5			20	Ω
		V _{IN} = 1.65 V, I _O = -4 mA			17			50	
I _{CC}	Quiescent Supply Current All Channels ON or OFF	V _{IN} = V _{CC} or GND I _{OUT} = 0	5.5			1.0		10	μA
	Analog Signal Range		V _{CC}	0		V _{CC}	0	V _{CC}	V
R _{RANGE}	On Resistance Over Signal Range (Note 3) (Note 7)	I _A = -30 mA, 0 ≤ V _{Bn} ≤ V _{CC}	4.5					25	Ω
		I _A = -24 mA, 0 ≤ V _{Bn} ≤ V _{CC}	3.0					50	
		I _A = -8 mA, 0 ≤ V _{Bn} ≤ V _{CC}	2.3					100	
		I _A = -4 mA, 0 ≤ V _{Bn} ≤ V _{CC}	1.65					300	
ΔR _{ON}	On Resistance Match Between Channels (Note 3) (Note 4) (Note 5)	I _A = -30 mA, V _{Bn} = 3.15	4.5		0.15				Ω
		I _A = -24 mA, V _{Bn} = 2.1	3.0		0.2				
		I _A = -8 mA, V _{Bn} = 1.6	2.3		0.5				
		I _A = -4 mA, V _{Bn} = 1.15	1.65		0.5				
R _{flat}	On Resistance Flatness (Note 3) (Note 4) (Note 6)	I _A = -30 mA, 0 ≤ V _{Bn} ≤ V _{CC}	5.0		6.0				Ω
		I _A = -24 mA, 0 ≤ V _{Bn} ≤ V _{CC}	3.3		12				
		I _A = -8 mA, 0 ≤ V _{Bn} ≤ V _{CC}	2.5		28				
		I _A = -4 mA, 0 ≤ V _{Bn} ≤ V _{CC}	1.8		125				

3. Measured by the voltage drop between A and B pins at the indicated current through the switch. On Resistance is determined by the lower of the voltages on the two (A or B Ports).
4. Parameter is characterized but not tested in production.
5. ΔR_{ON} = R_{ON} max – R_{ON} min measured at identical V_{CC}, temperature and voltage levels.
6. Flatness is defined as the difference between the maximum and minimum value of On Resistance over the specified range of conditions.
7. Guaranteed by Design.

NLASB3157

AC ELECTRICAL CHARACTERISTICS

Symbol	Parameter	Test Conditions	V _{CC} (V)	T _A = +25°C			T _A = -40°C to +85°C		Unit	Figure Number
				Min	Typ	Max	Min	Max		
t _{PHL} t _{PLH}	Propagation Delay Bus to Bus (Note 9)	V _I = OPEN	1.65–1.95 2.3–2.7 3.0–3.6 4.5–5.5					1.2 0.8 0.3	ns	Figures 2, 3
t _{PZL} t _{PZH}	Output Enable Time Turn On Time (A to B _n)	V _I = 2 × V _{CC} for t _{PZL} V _I = 0 V for t _{PZH}	1.65–1.95 2.3–2.7 3.0–3.6 4.5–5.5			23 13 6.9 5.2	7.0 3.5 2.5 1.7	24 14 7.6 5.7	ns	Figures 2, 3
t _{PLZ} t _{PHZ}	Output Disable Time Turn Off Time (A Port to B Port)	V _I = 2 × V _{CC} for t _{PLZ} V _I = 0 V for t _{PHZ}	1.65–1.95 2.3–2.7 3.0–3.6 4.5–5.5			12.5 7.0 5.0 3.5	3.0 2.0 1.5 0.8	13 7.5 5.3 3.8	ns	Figures 2, 3
t _{B-M}	Break Before Make Time (Note 8)		1.65–1.95 2.3–2.7 3.0–3.6 4.5–5.5				0.5 0.5 0.5 0.5		ns	Figure 4
Q	Charge Injection (Note 8)	C _L = 0.1 nF, V _{GEN} = 0 V R _{GEN} = 0 Ω	5.0 3.3		7.0 3.0				pC	Figure 5
OIRR	Off Isolation (Note 10)	R _L = 50 Ω f = 10 MHz	1.65–5.5		-57				dB	Figure 6
Xtalk	Crosstalk	R _L = 50 Ω f = 10 MHz	1.65–5.5		-54				dB	Figure 7
BW	-3 dB Bandwidth	R _L = 50 Ω	1.65–5.5		250				MHz	Figure 10
THD	Total Harmonic Distortion (Note 8)	R _L = 600 Ω 0.5 V _{P-P} f = 600 Hz to 20 kHz	5.0		0.011				%	

CAPACITANCE (Note 11)

Symbol	Parameter	Test Conditions	Typ	Max	Unit	Figure Number
C _{IN}	Select Pin Input Capacitance	V _{CC} = 0 V	2.3		pF	
C _{IO-B}	B Port Off Capacitance	V _{CC} = 5.0 V	6.5		pF	Figure 8
C _{IOA-ON}	A Port Capacitance when Switch is Enabled	V _{CC} = 5.0 V	18.5		pF	Figure 9

8. Guaranteed by Design.

9. This parameter is guaranteed by design but not tested. The bus switch contributes no propagation delay other than the RC delay of the On Resistance of the switch and the 50 pF load capacitance, when driven by an ideal voltage source (zero output impedance).

10. Off Isolation = 20 log₁₀ [V_A/V_{Bn}].

11. T_A = +25°C, f = 1 MHz, Capacitance is characterized but not tested in production.

APPENDIX A

DC ELECTRICAL EXTENDED AUTOMOTIVE TEMPERATURE RANGE CHARACTERISTICS

Symbol	Parameter	Test Conditions	V _{CC} (V)	T _A = +25°C			T _A = -55°C to +125°C		Unit
				Min	Typ	Max	Min	Max	
V _{IH}	HIGH Level Input Voltage		1.65–1.95 2.3–5.5				0.75 V _{CC} 0.7 V _{CC}		V
V _{IL}	LOW Level Input Voltage		1.65–1.95 2.3–5.5					0.25 V _{CC} 0.3 V _{CC}	V
I _{IN}	Input Leakage Current	0 ≤ V _{IN} ≤ 5.5 V	0–5.5		± 0.05	± 0.1		± 1	μA
I _{OFF}	OFF State Leakage Current	0 ≤ A, B ≤ V _{CC}	1.65–5.5		± 0.05	± 0.1		± 1	μA
R _{ON}	Switch On Resistance (Note 12)	V _{IN} = 0 V, I _O = 30 mA V _{IN} = 2.4 V, I _O = -30 mA V _{IN} = 4.5 V, I _O = -30 mA	4.5		3.0 5.0 7.0			8.5 13.0 15.0	Ω
		V _{IN} = 0 V, I _O = 24 mA V _{IN} = 3 V, I _O = -24 mA	3.0		4.0 10			11 20	
		V _{IN} = 0 V, I _O = 8 mA V _{IN} = 2.3 V, I _O = -8 mA	2.3		5.0 13			12 30	
		V _{IN} = 0 V, I _O = 4 mA V _{IN} = 1.65 V, I _O = -4 mA	1.65		6.5 17			20 50	
I _{CC}	Quiescent Supply Current All Channels ON or OFF	V _{IN} = V _{CC} or GND I _{OUT} = 0	5.5			1.0		10	μA
	Analog Signal Range		V _{CC}	0		V _{CC}	0	V _{CC}	V
R _{RANGE}	On Resistance Over Signal Range (Note 12) (Note 14)	I _A = -30 mA, 0 ≤ V _{Bn} ≤ V _{CC}	4.5					25	Ω
		I _A = -24 mA, 0 ≤ V _{Bn} ≤ V _{CC}	3.0					50	
		I _A = -8 mA, 0 ≤ V _{Bn} ≤ V _{CC}	2.3					100	
		I _A = -4 mA, 0 ≤ V _{Bn} ≤ V _{CC}	1.65					300	

12. Measured by the voltage drop between A and B pins at the indicated current through the switch. On Resistance is determined by the lower of the voltages on the two (A or B Ports).

13. Flatness is defined as the difference between the maximum and minimum value of On Resistance over the specified range of conditions.

14. Guaranteed by Design.

* For ΔR_{ON}, R_{FLAT}, Q, OIRR, Xtalk, BW, THD, and CIN see -40°C to 85°C section.

NLASB3157

APPENDIX A

AC ELECTRICAL EXTENDED AUTOMOTIVE TEMPERATURE RANGE CHARACTERISTICS

Symbol	Parameter	Test Conditions	V _{CC} (V)	T _A = +25°C			T _A = -55°C to +125°C		Unit	Figure Number
				Min	Typ	Max	Min	Max		
t _{PHL} t _{PLH}	Propagation Delay Bus to Bus (Note 16)	V _I = OPEN	1.65–1.95 2.3–2.7 3.0–3.6 4.5–5.5					1.2 0.8 0.3	ns	Figures 2, 3
t _{PZL} t _{PZH}	Output Enable Time Turn On Time (A to B _n)	V _I = 2 × V _{CC} for t _{PZL} V _I = 0 V for t _{PZH}	1.65–1.95 2.3–2.7 3.0–3.6 4.5–5.5			23 13 6.9 5.2	7.0 3.5 2.5 1.7	24 14 9.0 7.0	ns	Figures 2, 3
t _{PLZ} t _{PHZ}	Output Disable Time Turn Off Time (A Port to B Port)	V _I = 2 × V _{CC} for t _{PLZ} V _I = 0 V for t _{PHZ}	1.65–1.95 2.3–2.7 3.0–3.6 4.5–5.5			12.5 7.0 5.0 3.5	3.0 2.0 1.5 0.8	13 7.5 6.5 5.0	ns	Figures 2, 3
t _{B-M}	Break Before Make Time (Note 15)		1.65–1.95 2.3–2.7 3.0–3.6 4.5–5.5				0.5 0.5 0.5 0.5		ns	Figure 4

15. Guaranteed by Design.

16. This parameter is guaranteed by design but not tested. The bus switch contributes no propagation delay other than the RC delay of the On Resistance of the switch and the 50 pF load capacitance, when driven by an ideal voltage source (zero output impedance).

* For ΔR_{ON} , R_{FLAT} , Q, OIRR, Xtalk, BW, THD, and CIN see -40°C to 85°C section.

NLASB3157

AC LOADING AND WAVEFORMS

NOTE: Input driven by 50 Ω source terminated in 50 Ω
 NOTE: C_L includes load and stray capacitance
 NOTE: Input PRR = 1.0 MHz; $t_W = 500$ ns

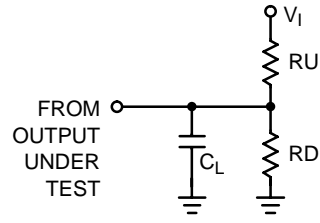

Figure 2. AC Test Circuit

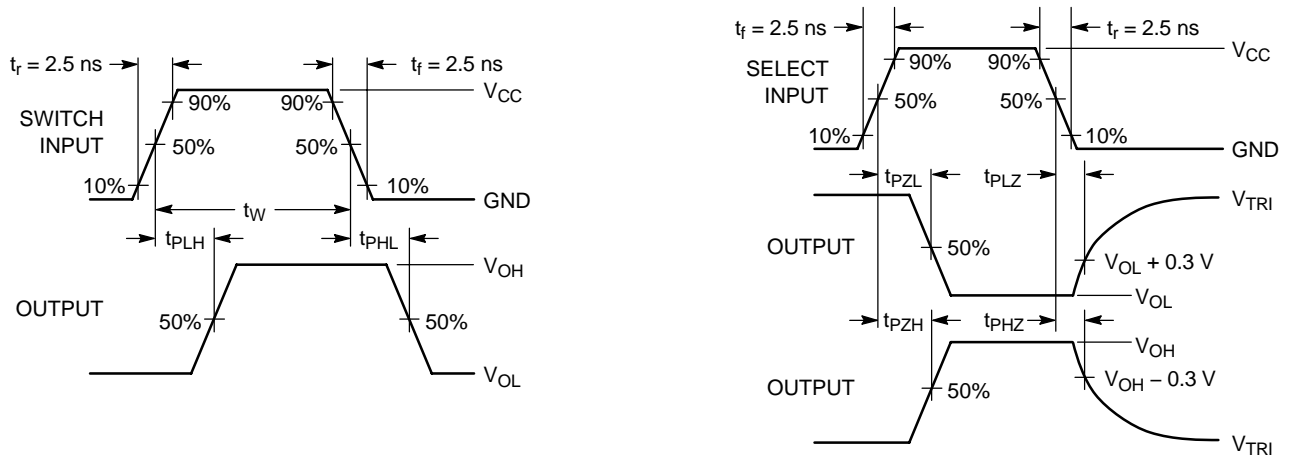

Figure 3. AC Waveforms



Figure 4. Break Before Make Interval Timing

AC LOADING AND WAVEFORMS

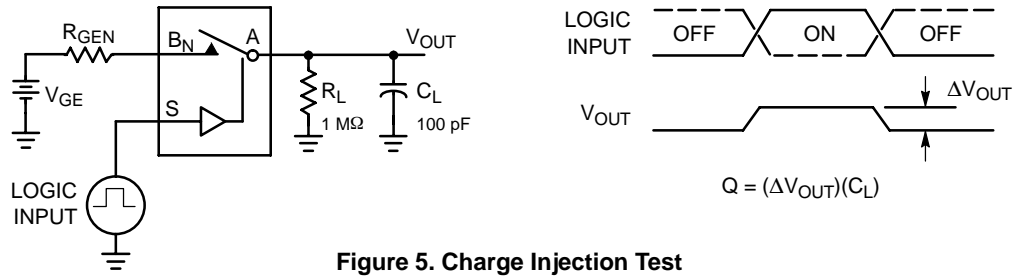

Figure 5. Charge Injection Test

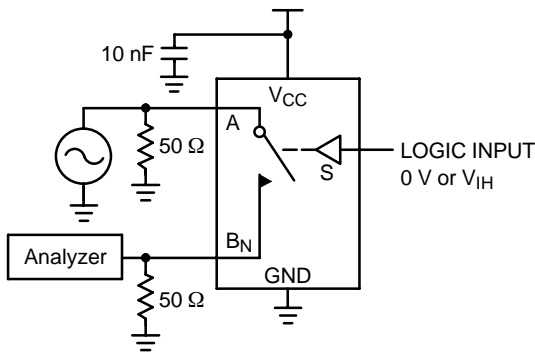

Figure 6. Off Isolation

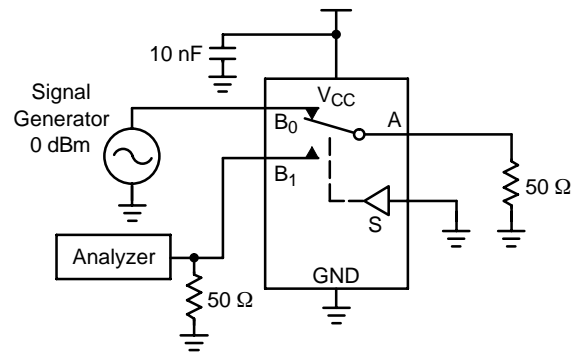

Figure 7. Crosstalk

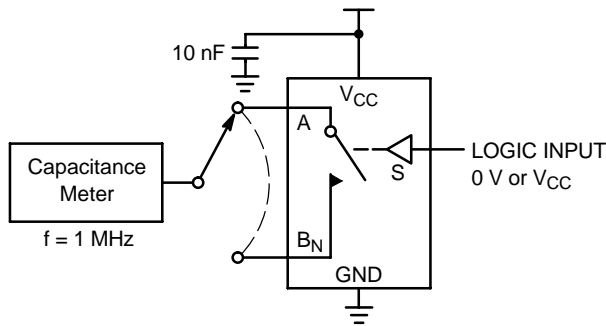

Figure 8. Channel Off Capacitance

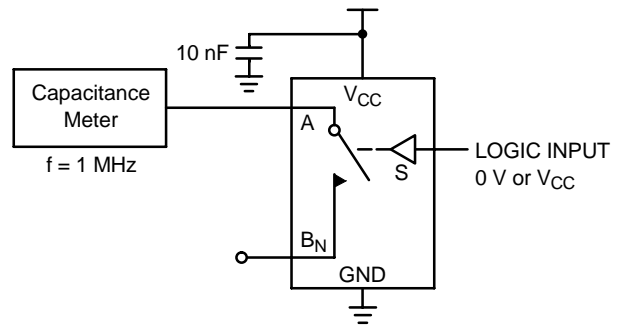

Figure 9. Channel On Capacitance

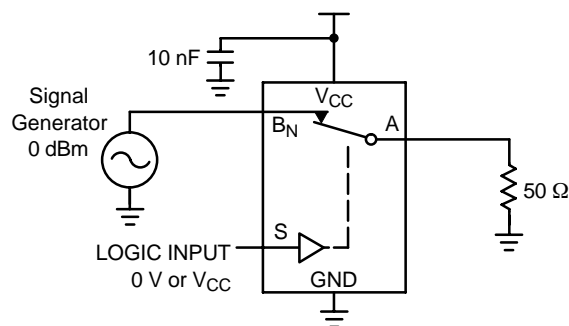
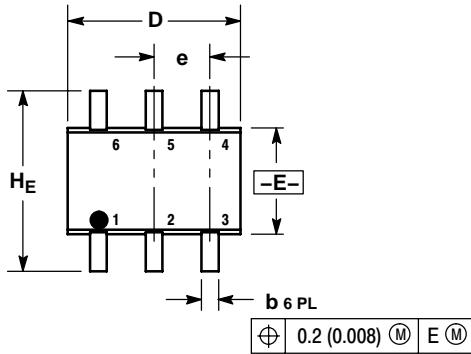

Figure 10. Bandwidth

NLASB3157

PACKAGE DIMENSIONS

SC-88/SOT-363/SC-70
 DF SUFFIX
 CASE 419B-02
 ISSUE W



- NOTES:
 1. DIMENSIONING AND TOLERANCING PER ANSI Y14.5M, 1982.
 2. CONTROLLING DIMENSION: INCH.
 3. 419B-01 OBSOLETE, NEW STANDARD 419B-02.

DIM	MILLIMETERS			INCHES		
	MIN	NOM	MAX	MIN	NOM	MAX
A	0.80	0.95	1.10	0.031	0.037	0.043
A1	0.00	0.05	0.10	0.000	0.002	0.004
A3	0.20 REF			0.008 REF		
b	0.10	0.21	0.30	0.004	0.008	0.012
C	0.10	0.14	0.25	0.004	0.005	0.010
D	1.80	2.00	2.20	0.070	0.078	0.086
E	1.15	1.25	1.35	0.045	0.049	0.053
e	0.65 BSC			0.026 BSC		
L	0.10	0.20	0.30	0.004	0.008	0.012
HE	2.00	2.10	2.20	0.078	0.082	0.086

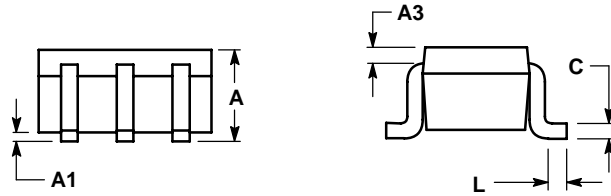

SOLDERING FOOTPRINT*

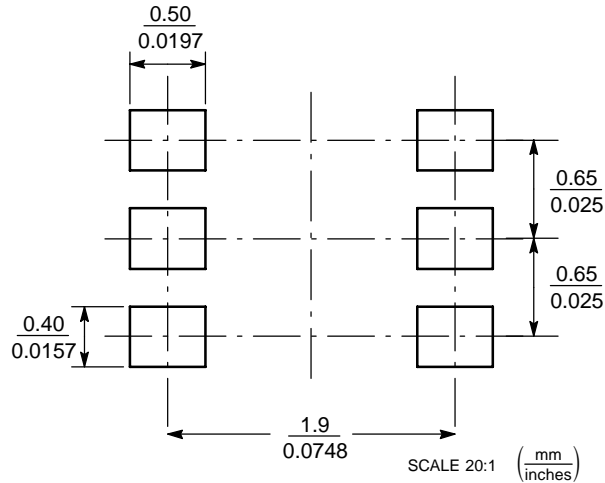

*For additional information on our Pb-Free strategy and soldering details, please download the ON Semiconductor Soldering and Mounting Techniques Reference Manual, SOLDERRM/D.

NLASB3157

PACKAGE DIMENSIONS

WDFN6, 1.2x1.0x0.4P
 MT SUFFIX
 CASE 506AS-01
 ISSUE A

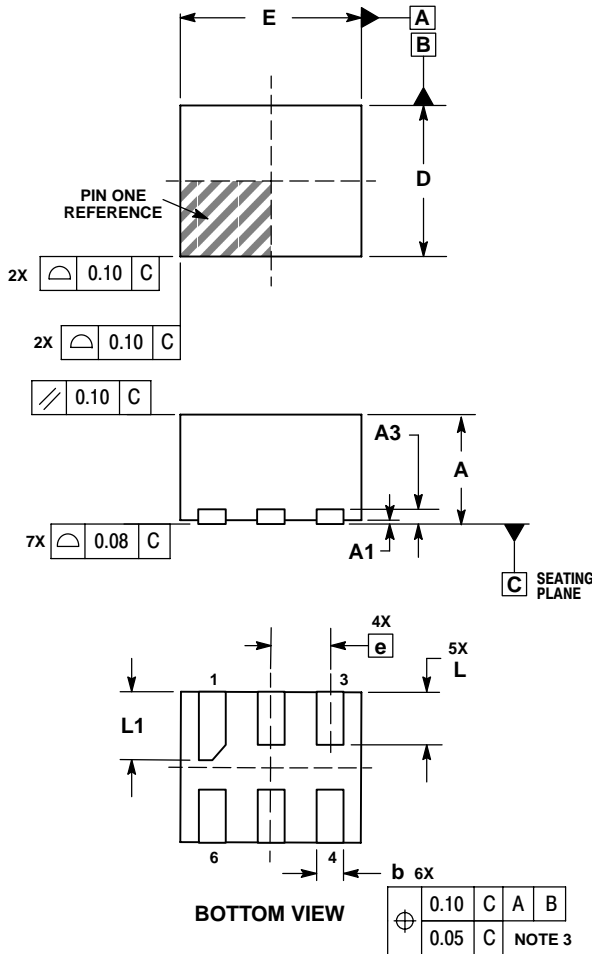

NOTES:

1. DIMENSIONING AND TOLERANCING PER ASME Y14.5M, 1994.
2. CONTROLLING DIMENSION: MILLIMETERS.
3. DIMENSION b APPLIES TO PLATED TERMINAL AND IS MEASURED BETWEEN 0.25 AND 0.30mm FROM TERMINAL.
4. COPLANARITY APPLIES TO THE EXPOSED PAD AS WELL AS THE TERMINALS.

DIM	MILLIMETERS	
	MIN	MAX
A	0.70	0.80
A1	0.00	0.05
A3	0.20 REF	
b	0.15	0.25
D	1.00 BSC	
E	1.20 BSC	
e	0.40 BSC	
L	0.30	0.40
L2	0.40	0.50

MOUNTING FOOTPRINT*

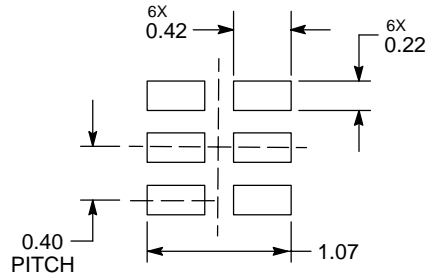

DIMENSIONS: MILLIMETERS

*For additional information on our Pb-Free strategy and soldering details, please download the ON Semiconductor Soldering and Mounting Techniques Reference Manual, SOLDERRM/D.

ON Semiconductor and are registered trademarks of Semiconductor Components Industries, LLC (SCILLC). SCILLC reserves the right to make changes without further notice to any products herein. SCILLC makes no warranty, representation or guarantee regarding the suitability of its products for any particular purpose, nor does SCILLC assume any liability arising out of the application or use of any product or circuit, and specifically disclaims any and all liability, including without limitation special, consequential or incidental damages. "Typical" parameters which may be provided in SCILLC data sheets and/or specifications can and do vary in different applications and actual performance may vary over time. All operating parameters, including "Typicals" must be validated for each customer application by customer's technical experts. SCILLC does not convey any license under its patent rights nor the rights of others. SCILLC products are not designed, intended, or authorized for use as components in systems intended for surgical implant into the body, or other applications intended to support or sustain life, or for any other application in which the failure of the SCILLC product could create a situation where personal injury or death may occur. Should Buyer purchase or use SCILLC products for any such unintended or unauthorized application, Buyer shall indemnify and hold SCILLC and its officers, employees, subsidiaries, affiliates, and distributors harmless against all claims, costs, damages, and expenses, and reasonable attorney fees arising out of, directly or indirectly, any claim of personal injury or death associated with such unintended or unauthorized use, even if such claim alleges that SCILLC was negligent regarding the design or manufacture of the part. SCILLC is an Equal Opportunity/Affirmative Action Employer. This literature is subject to all applicable copyright laws and is not for resale in any manner.

PUBLICATION ORDERING INFORMATION

LITERATURE FULFILLMENT:
 Literature Distribution Center for ON Semiconductor
 P.O. Box 5163, Denver, Colorado 80217 USA
Phone: 303-675-2175 or 800-344-3860 Toll Free USA/Canada
Fax: 303-675-2176 or 800-344-3867 Toll Free USA/Canada
Email: orderlit@onsemi.com

N. American Technical Support: 800-282-9855 Toll Free USA/Canada
Europe, Middle East and Africa Technical Support:
 Phone: 421 33 790 2910
Japan Customer Focus Center
 Phone: 81-3-5773-3850

ON Semiconductor Website: www.onsemi.com
Order Literature: <http://www.onsemi.com/orderlit>

For additional information, please contact your local Sales Representative