



M.S.KENNEDY CORP.

40 AMP, 34V, 3 PHASE BRUSHLESS MOTOR SPEED CONTROLLER

1695

4707 Dey Road Liverpool, N.Y. 13088

(315) 701-6751

FEATURES:

- 34V Maximum Supply Voltage - +28V Nominal
- 40 Amps DC @ 70°C Case Temperature
- Shoot-through, Cross Conduction Protection
- Hall Sensing and Commutation Circuitry On Board
- Pulse by Pulse 50 Amp Current Limit

EQUIVALENT SCHEMATIC

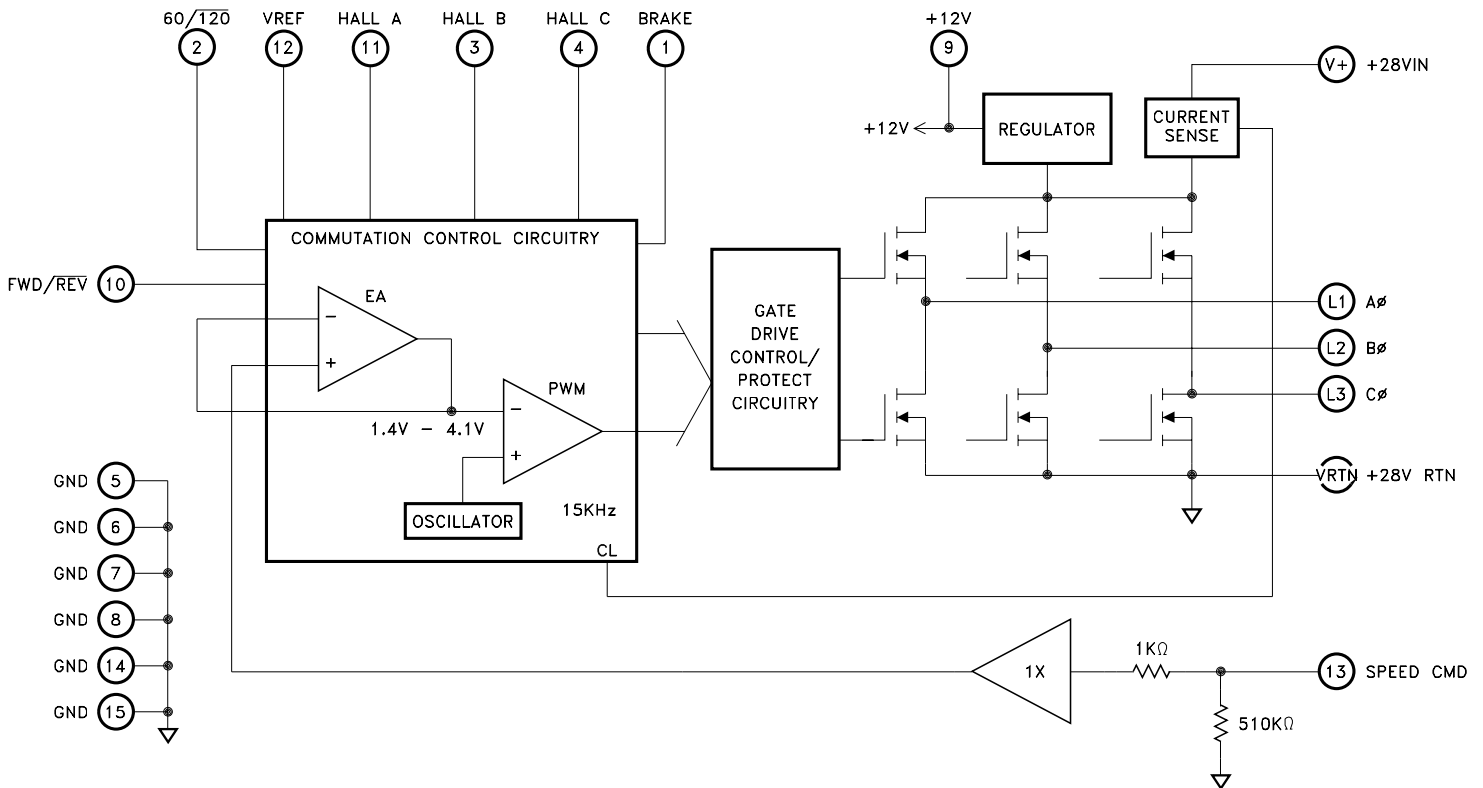

TYPICAL APPLICATIONS

- Fan/Blower Speed Control
- Azimuth/Elevation Antenna Control
- Optical Tracking Control
- Robot Velocity Control

PIN-OUT INFORMATION

PCB PADS		HEADER CONNECTION	
L1	A PHASE OUT	1	BRAKE
L2	B PHASE OUT	2	60/120
L3	C PHASE OUT	3	HALL B
V+	+28V IN	4	HALL C
VRTN	+28V RTN	5	GND
		6	GND
		7	GND
		8	GND
		9	+12V
		10	FWD/REV
		11	HALL A
		12	VREF
		13	SPEED COMMAND
		14	GND
		15	GND

ABSOLUTE MAXIMUM RATINGS ^③

High Voltage Supply +34V
 Speed Command +12V
 Hall A,B,C,Brake,Disable +6.24V
 VREF Output Current 25mA
 Continuous Output Current 50 Amps DC
 Peak Output Current 75 Amps (10 μ Sec)

Thermal Resistance R θ C-A 0.85 $^{\circ}$ C/W
 Storage Temperature Range -40 $^{\circ}$ C to +85 $^{\circ}$ C
 Solder Temperature +300 $^{\circ}$ C (10 seconds)
 Case Operating Temperature -40 $^{\circ}$ C to +85 $^{\circ}$ C
 Junction Temperature +150 $^{\circ}$ C

ELECTRICAL SPECIFICATIONS

Parameter ^①	Min.	Typ.	Max.	Units
PWM Clock Frequency	10	15	20	KHz
V+ Quiescent Current (No PWM)	-	100	200	mA
Hall Inputs				
VIL	-	-	0.8	V
HIL	3.0	-	-	V
Speed Command Input Range	1.2	-	4.5	V
Speed Command Input Current (VIN = 5V)	-	-	1.5	mA
VREF	5.9	6.24	6.57	V
Output Section				
Voltage Drop Across Bridge (1 Upper + 1 Lower, 50Amps)	-	0.64	1.125	V
Leakage Current (@ V+ = 34V)	-	-	100	μ A
Diode VSD	-	-	1.4	V
trr	-	90	-	nSEC
Deadtime	-	5	-	μ SEC
Current Limit	44	50	56	Amps

NOTES:

- ① V+ = 28V, BRAKE = GND, TC = 25 $^{\circ}$ C unless otherwise specified.
- ② Guaranteed by design but not tested. Typical parameters are representative of actual device performance but are for reference only.
- ③ Continuous operation at or above absolute maximum ratings may adversely effect the device performance and/or life cycle.

APPLICATION NOTES

MSK 1695 PIN DESCRIPTIONS

V+ - is the power connection from the hybrid to the bus. The external wiring to the pin should be sized according to the RMS current required by the motor. This pin should be bypassed by a high quality monolithic ceramic capacitor for high frequencies and enough bulk capacitance to keep the V+ power supply from drooping.

AØ OUT, BØ OUT, CØ OUT-are the connections to the motor phase windings from the bridge output. The wiring to these pins should be sized according to the motor current requirements. There are no internal short circuit protection provisions for these output pins in the hybrid. Shorts to V+ or ground from these pins must be avoided or the bridge will be destroyed.

VRTN-is the power return connection from the hybrid to the bus. All ground returns internal to the hybrid connect to this point in a star configuration. All external ground connections to this point should be made in a similar fashion. The V+ capacitors should be returned to this pin as close as possible. Wire sizing to this pin connection should be made according to the required current.

GND - are the ground pins that connect to the ground plane for circuitry inside the device.

BRAKE - is the pin for commanding the output bridge into a motor brake mode. When this pin is taken low, normal operation of the hybrid proceeds. When this pin is taken high, the three high side switches in the bridge turn off and the three lowside switches turn fully on. This will cause rapid deceleration of the motor and will cease motor operation until taken low again. The pin left open is internally pulled high.

60/120-is a pin for selecting the orientation of the commutation scheme of the motor. A high state will produce 60/300 degree commutation, where as a low state will produce 120/240 degree commutation. Logic levels for this input are TTL compatible. It is internally pulled high.

HALL A, B & C - are the hall input pins from the hall devices in the motor. These pins are internally pulled up to 6.25 volts. The halls reflect a 120/240 degree commutation scheme.

VREF - is a 6.25 volt regulated output that can be used to power the hall devices in various motors. Up to 15 milliamps of current is available.

SPEED COMMAND - is the input for controlling the motor speed. The operational command voltage range should be 0 volts to +5 volts. Negative input voltages must be avoided while the maximum positive input voltage should not exceed +5 volts.

COMMUTATION TRUTH TABLE

HALL SENSOR PHASING			DIRECTION=FWD			DIRECTION=REV		
120°			AØ	BØ	CØ	AØ	BØ	CØ
HALL A	HALL B	HALL C	AØ	BØ	CØ	AØ	BØ	CØ
1	0	0	H	-	L	L	-	H
1	1	0	-	H	L	-	L	H
0	1	0	L	H	-	H	L	-
0	1	1	L	-	H	H	-	L
0	0	1	-	L	H	-	H	L
1	0	1	H	L	-	L	H	-
1	1	1	-	-	-	-	-	-
0	0	0	-	-	-	-	-	-
X	X	X	L	L	L	L	L	L

1 = High Level H = SOURCE
 0 = Low Level L = SINK
 X = Don't Care - = OPEN

BUS VOLTAGE FILTER CAPACITORS

The size and placement of the capacitors for the DC bus has a direct bearing on the amount of noise filtered and also on the size and duration of the voltage spikes seen by the bridge. What is being created is a series RLC tuned circuit with a resonant frequency that is seen as a damped ringing every time one of the transistors switches. For the resistance, wire resistance, power supply impedance and capacitor ESR all add up for the equivalent lumped resistance in the circuit. The inductance can be figured at about 30 nH per inch from the power supply. Any voltage spikes are on top of the bus voltage and the back EMF from the motor. All this must be taken into account when designing and laying out the system. If everything has been minimized, there is another solution. A second capacitance between 5 and 10 times the first capacitor and it should either have some ESR or a resistor can be added in series with the second capacitor to help damp the voltage spikes.

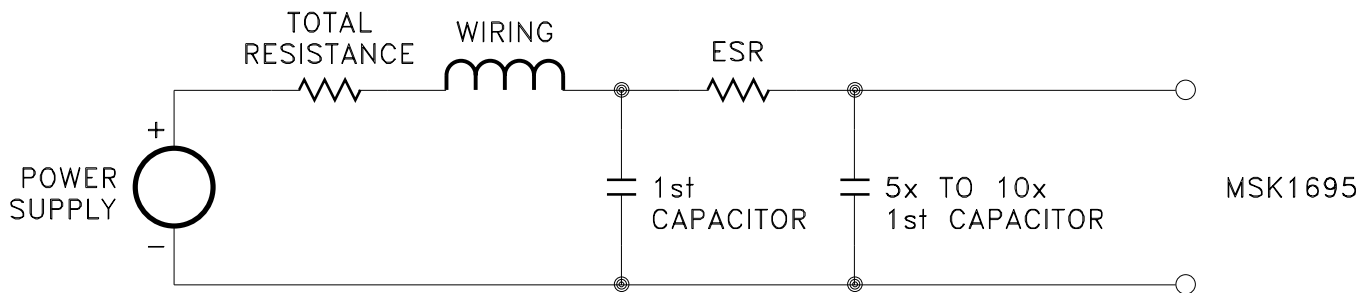

Be careful of the ripple current in all the capacitors. Excessive ripple current, beyond what the capacitors can handle, will destroy the capacitors.

LOW POWER STARTUP

When starting up a system utilizing the MSK 1695 for the first time, there are a few things to keep in mind. First, because of the small size of the module, short circuiting the output phases either to ground or the DC bus will destroy the bridge. The current limiting and control only works for current actually flowing through the bridge. The current limit sensor has to see the current in order for the electronics to control it. If possible, for startup use a lower current power supply to test out connections and the low current stability. With a limited current supply, even if the controller locks up, the dissipation will be limited.

MSK1695 TYPICAL APPLICATION CIRCUIT

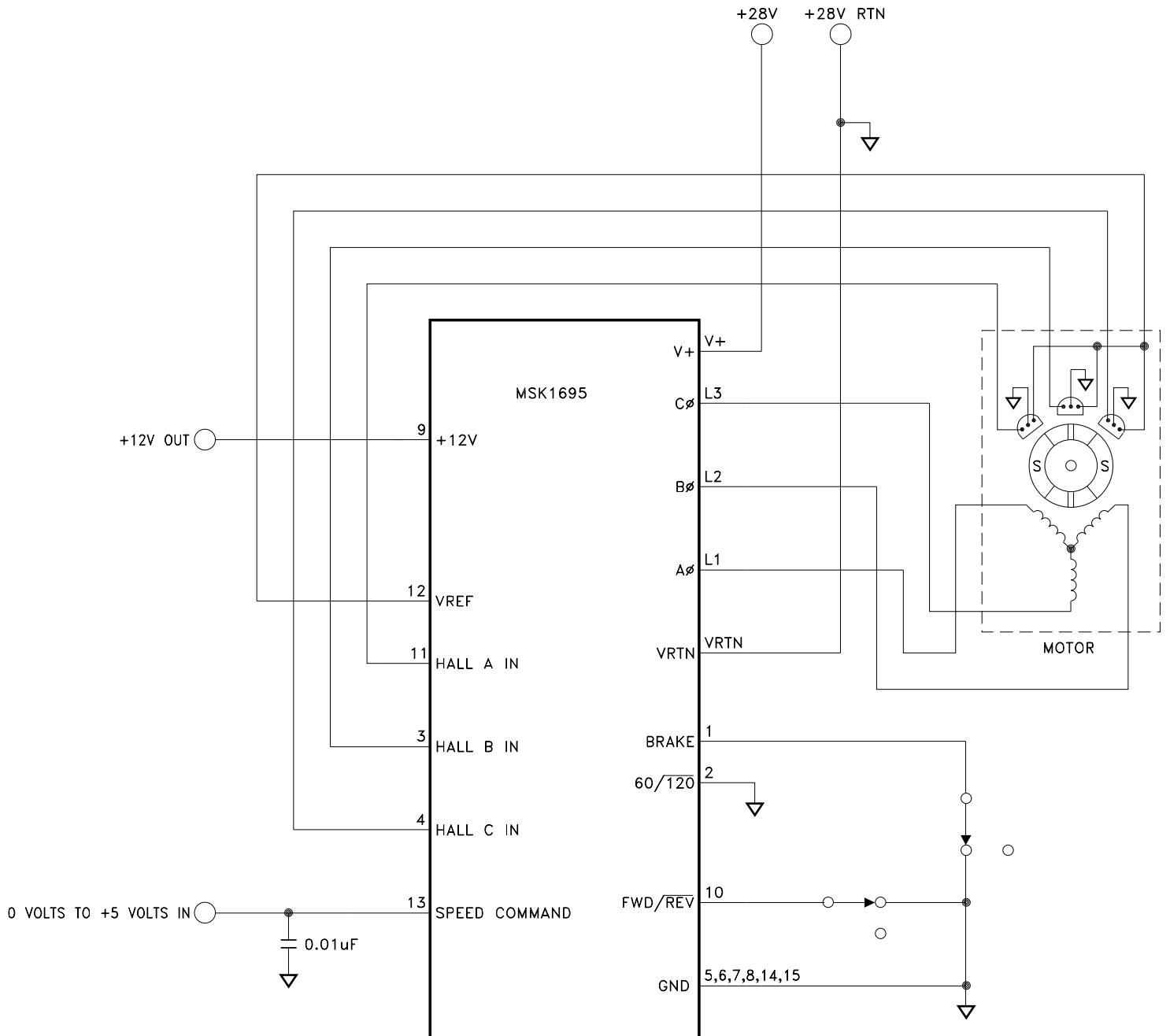

MECHANICAL SPECIFICATIONS

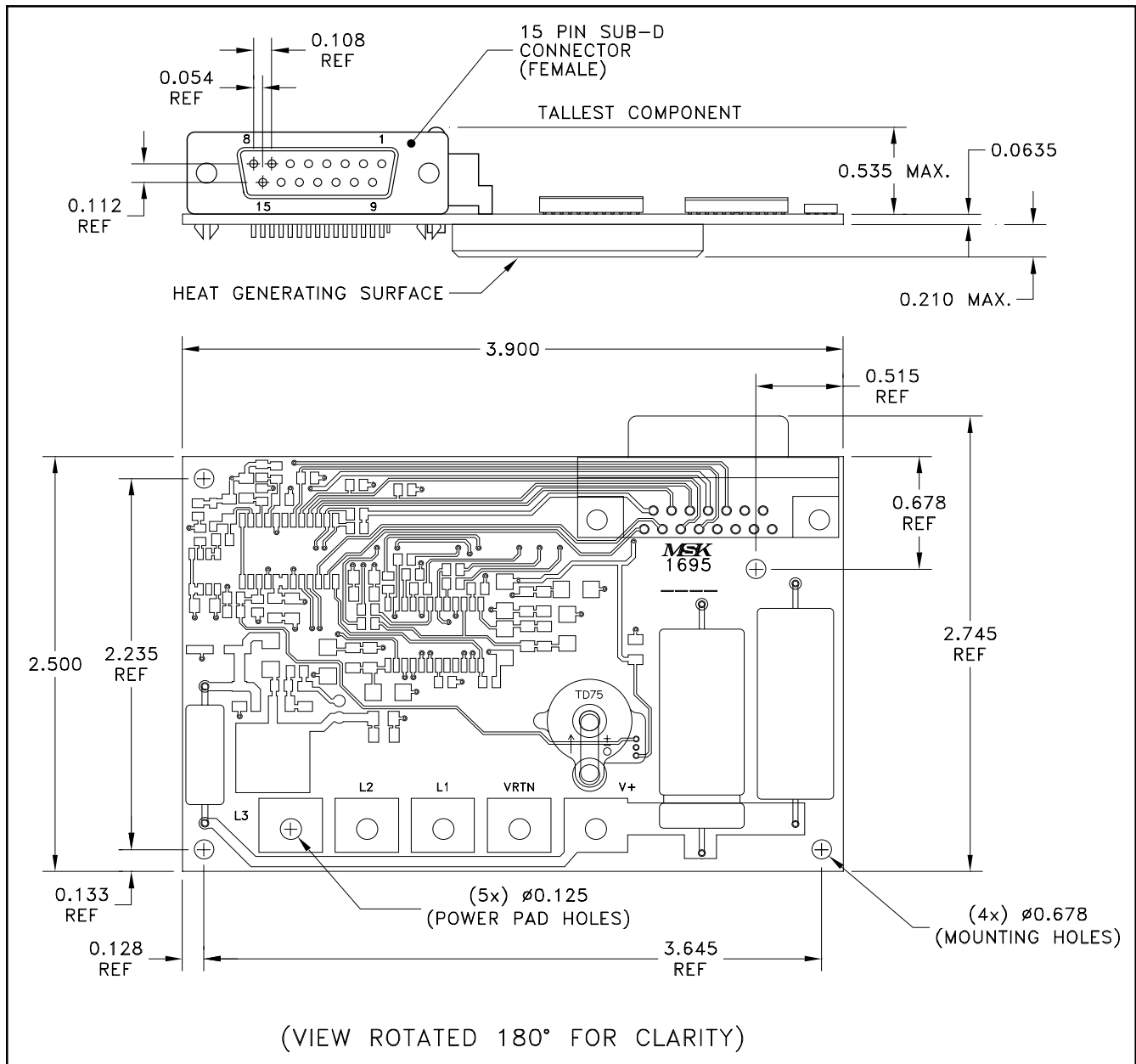

ORDERING INFORMATION

Part Number	Screening Level
MSK1695	Industrial

M.S. Kennedy Corp.
 4707 Dey Road Liverpool, New York 13088
 Phone (315) 701-6751
 FAX (315) 701-6752
www.mskennedy.com

The information contained herein is believed to be accurate at the time of printing. MSK reserves the right to make changes to its products or specifications without notice, however, and assumes no liability for the use of its products.