

**MRF3866, R1, R2**  
**MRF3866G, R1, R2**

\* G Denotes RoHS Compliant, Pb Free Terminal Finish

**RF & MICROWAVE DISCRETE  
LOW POWER TRANSISTORS**

Features

- Low Cost SO-8 Plastic Surface Mount Package.
- S-Parameter Characterization
- Tape and Reel Packaging Options Available
- Maximum Available Gain = 17 dB @ 300 MHz

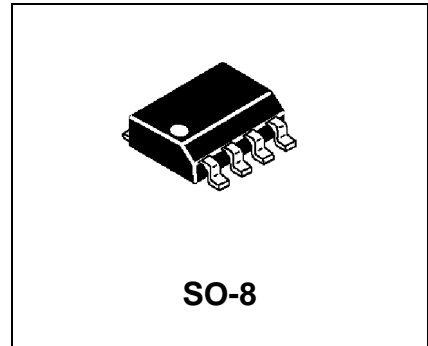

R1 suffix—Tape and Reel, 500 units  
R2 suffix—Tape and Reel, 2500 units

DESCRIPTION: Designed for general-purpose RF amplifier applications, such as; pre-drivers, Oscillators, etc.

ABSOLUTE MAXIMUM RATINGS (T<sub>case</sub> = 25°C)

Symbol	Parameter	Value	Unit
V <sub>CEO</sub>	Collector-Emitter Voltage	30	Vdc
V <sub>CBO</sub>	Collector-Base Voltage	55	Vdc
V <sub>EBO</sub>	Emitter-Base Voltage	3.5	Vdc
I <sub>C</sub>	Collector Current	400	mA

Thermal Data

P <sub>D</sub>	Total Device Dissipation @ TC = 25°C Derate above 25°C	1.0 8	Watts mW/ °C
----------------	---	----------	-----------------

<b>MRF3866, R1, R2</b> <b>MRF3866G, R1, R2</b>
---

**ELECTRICAL SPECIFICATIONS (T<sub>case</sub> = 25°C)**
**STATIC  
(off)**

Symbol	Test Conditions	Value			Unit
		Min.	Typ.	Max.	
BVCER	Collector-Emitter Breakdown Voltage (I <sub>C</sub> = 5.0 mA <sub>dc</sub> , I <sub>B</sub> = 0, r <sub>be</sub> = 10 Ohms)	55	-	-	V <sub>dc</sub>
BVCBO	Collector-Base Breakdown Voltage (I <sub>C</sub> = 0.1 mA <sub>dc</sub> , I <sub>E</sub> = 0)	55	-	-	V <sub>dc</sub>
BVEBO	Emitter-Base Breakdown Voltage (I <sub>E</sub> = 0.1 mA <sub>dc</sub> , I <sub>C</sub> = 0)	3.5	-	-	V <sub>dc</sub>
ICEO	Collector Cutoff Current (V <sub>CE</sub> = 15 V <sub>dc</sub> , V <sub>BE</sub> = 0 V <sub>dc</sub> )	-	-	.02	mA

**(on)**

HFE	DC Current Gain (I <sub>C</sub> = 360 mA <sub>dc</sub> , V <sub>CE</sub> = 5.0 V <sub>dc</sub> ) (I <sub>C</sub> = 50 mA <sub>dc</sub> , V <sub>CE</sub> = 5.0 V <sub>dc</sub> )	5.0 10	- -	250 200	
-----	--	-----------	--------	------------	--

**DYNAMIC**

Symbol	Test Conditions	Value			Unit
		Min.	Typ.	Max.	
COB	Output Capacitance (V <sub>CB</sub> = 30 V <sub>dc</sub> , I <sub>E</sub> = 0, f = 1.0 MHz)	-	1.6	2.0	pF
F <sub>tau</sub>	Current-Gain Bandwidth Product (I <sub>C</sub> = 50 mA <sub>dc</sub> , V <sub>CE</sub> = 15 V <sub>dc</sub> , f = 200 MHz)	800	1000	-	MHz

<b>MRF3866, R1, R2</b> <b>MRF3866G, R1, R2</b>
---

**FUNCTIONAL**

Symbol	Test Conditions	Value			Unit
		Min.	Typ.	Max.	
$G_{U\max}$	Maximum Unilateral Gain IC = 50 mAdc, VCE = 15 Vdc, f = 300 MHz	-	15	-	dB
MAG	Maximum Available Gain IC = 50 mAdc, VCE = 15 Vdc, f = 300 MHz	-	17	-	dB
$ S_{21} ^2$	Insertion Gain IC = 50 mAdc, VCE = 15 Vdc, f = 300 MHz	11.5	12.5	-	dB
$G_{pe}$	Amplifier Power Gain (V <sub>CC</sub> = 28 Vdc; P <sub>OUT</sub> = 1 W; f = 400 MHz)	10			dB
$\eta$	Collector Efficiency (V <sub>CC</sub> = 28 Vdc; P <sub>OUT</sub> = 1 W; f = 400 MHz)	45			%

Table 1. Common Emitter S-Parameters, @ VCE = 15 V, IC = 50 mA

f (MHz)	S11		S21		S12		S22	
	S11	$\angle \phi$	S21	$\angle \phi$	S12	$\angle \phi$	S22	$\angle \phi$
100	.632	-164	12.94	93	.018	53	.315	-27
300	.683	-179	4.33	75	.039	61	.307	-29
500	.710	171	2.57	62	.056	61	.346	-43
700	.717	162	1.82	51	.071	62	.393	-58
1000	.715	158	1.24	36	.092	65	.455	-72

# MRF3866, R1, R2 MRF3866G, R1, R2

## RF Low Power PA, LNA, and General Purpose Discrete Selector Guide

Package	Device	Type	GPE Freq (MHz)	Pout (watts)	GPE (dB)	Efficiency (%)	GPE VCC	BYCEO	IC max (mA)
SO-8	MRF4427, R2	NPN	175	0.15	18	60	12	20	400
TO-39	2N4427	NPN	175	1	10	50	12	20	400
POWER MACRO	MRF553	NPN	175	1.5	11.5	60	12.5	16	500
POWER MACRO	MRF553T	NPN	175	1.5	11.5	50	12.5	16	500
TO-39	MRF607	NPN	175	1.75	11.5	50	12.5	16	330
TO-39	2N6255	NPN	175	3	7.8	50	12.5	18	1000
TO-72	2N5179	NPN	200		20	6	12	50	
MACRO X	MRF559	NPN	512	0.5	10	65	7.5	16	150
MACRO X	MRF559	NPN	512	0.5	13	60	12.5	16	150
TO-39	2N3866A	NPN	400	1	10	45	28	30	400
SO-8	MRF3866, R1, R2	NPN	400	1	10	45	28	30	400
POWER MACRO	MRF555	NPN	470	1.5	11	50	12.5	16	400
POWER MACRO	MRF555T	NPN	470	1.5	11	50	12.5	16	400
MACRO X	MRF559	NPN	870	0.5	6.5	70	7.5	16	150
MACRO X	MRF559	NPN	870	0.5	9.5	65	12.5	16	150
SO-8	MRF8372, R1, R2	NPN	870	0.75	8	55	12.5	16	200
POWER MACRO	MRF557	NPN	870	1.5	8	55	12.5	16	400
POWER MACRO	MRF557T	NPN	870	1.5	8	55	12.5	16	400

Package	Device	Type	Freq (MHz)	NF (dB)	NF IC (mA)	NF VCE	GN (dB)	Gu Max (dB)	Fleu (MHz)	Ccb(pF)	BYCEO	IC max (mA)
TO-39	2N5109	NPN	200	3	10	15		12	1200	3.5	20	400
TO-39	MRF5943C	NPN	200	3.4	30	15		11.4	1000		30	400
SO-8	MRF5943, R1, R2	NPN	200	3.4	30	15		15	1300		30	400
TO-72	2N5179	NPN	200	4.5	1.5	6		17	900	1	12	50
TO-72	2N2857	NPN	300	5.5	50	6		13	1600	1	15	40
TO-39	MRF517	NPN	300	7.5	50	15		5.5	4600	3	25	150
TO-72	MRF904	NPN	450	1.5	5	6		11	4000	1	15	30
TO-72	2N6304	NPN	450	5	2	5		14	1400	1	15	50
MACRO T	BFR91	NPN	500	1.9	2	5	11	16.5	5000	1	12	35
MACRO T	BFR96	NPN	500	2	10	10		14.5	500	2.6	15	100
SO-8	MRF5812, R1, R2	NPN	500	2	50	10	15.5	17.8	5000		15	200
MACRO X	MRF581A	NPN	500	2	50	10	14	15	5000		15	200
Macro	BFR90	NPN	500	2.4	2	10	15	18	5000	1	15	30
TO-72	BFY90	NPN	500	2.5	2	5		20	1300		15	50
TO-72	MRF914	NPN	500	2.5	5	10		15	4500		12	40
MACRO X	MRF581	NPN	500	2.5	50	10	15	17.8	5000		16	200
TO-39	MRF586	NPN	500	3	90	15	11	14.5	6500	2.2	17	200
MACRO X	MRF951	NPN	1000	1.3	5	6	14	17	8000	0.45	10	100
MACRO X	MRF571	NPN	1000	1.5	10	6	10		8000	1	10	70
MACRO T	BFR91	NPN	1000	2.5	2	5	8	11	5000	1	12	35
MACRO T	BFR90	NPN	1000	3	2	10	10	12.5	5000	1	15	30
TO-39	MRF545	PNP						14	1400	2	70	400
TO-39	MRF544	NPN						13.5	1500		70	400

RF (Low Power PA / General Purpose) Selection Guide

RF (LNA / General Purpose) Selection Guide

### Low Cost RF Plastic Package Options

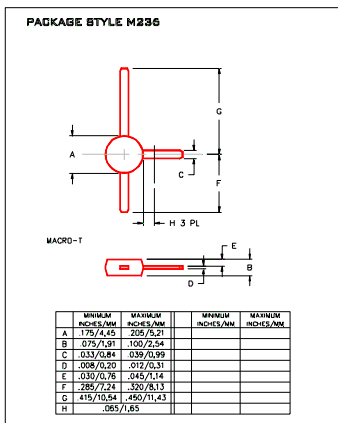

Macro T

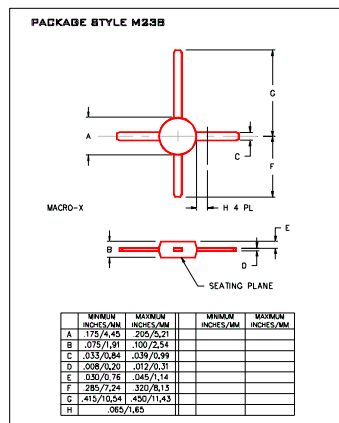

Macro X

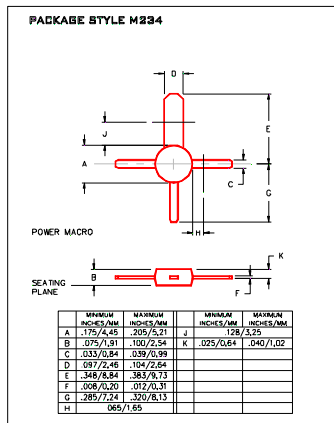

Power Macro

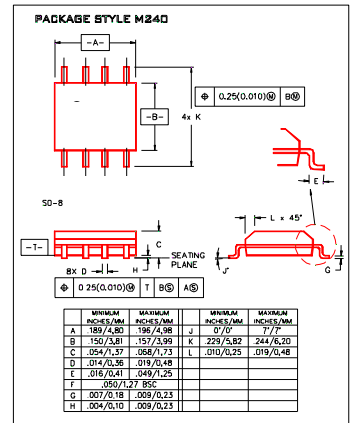

SO-8

**MRF3866, R1, R2  
MRF3866G, R1, R2**

