

# High Temperature Accuracy Integrated Silicon Pressure Sensor for Measuring Absolute Pressure, On-Chip Signal Conditioned, Temperature Compensated and Calibrated

Motorola's MPXA6115A/MPXH6115A series sensor integrates on-chip, bipolar op amp circuitry and thin film resistor networks to provide a high output signal and temperature compensation. The small form factor and high reliability of on-chip integration make the Motorola pressure sensor a logical and economical choice for the system designer.

The MPXA6115A/MPXH6115A series piezoresistive transducer is a state-of-the-art, monolithic, signal conditioned, silicon pressure sensor. This sensor combines advanced micromachining techniques, thin film metallization, and bipolar semiconductor processing to provide an accurate, high level analog output signal that is proportional to applied pressure.

Figure 1 shows a block diagram of the internal circuitry integrated on a pressure sensor chip.

### Features

- Improved Accuracy at High Temperature
- Available in Small and Super Small Outline Packages
- 1.5% Maximum Error over 0° to 85°C
- Ideally suited for Microprocessor or Microcontroller-Based Systems
- Temperature Compensated from -40° to +125°C
- Durable Thermoplastic (PPS) Surface Mount Package

### Application Examples

- Aviation Altimeters
- Industrial Controls
- Engine Control/Manifold Absolute Pressure (MAP)
- Weather Station and Weather Reporting Device Barometers

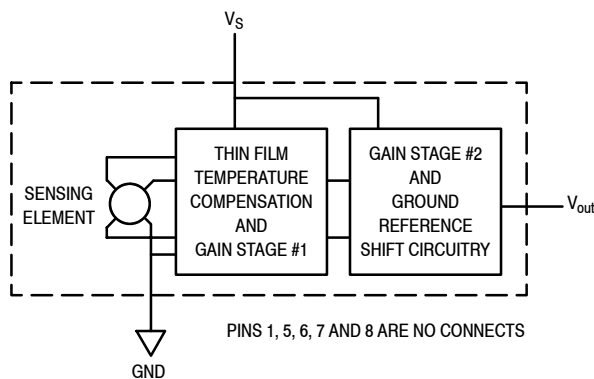
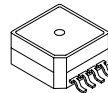

**Figure 1. Fully Integrated Pressure Sensor Schematic**

## MPXA6115A MPXH6115A SERIES

**INTEGRATED  
 PRESSURE SENSOR**  
 15 to 115 kPa (2.2 to 16.7 psi)  
 0.2 to 4.8 Volts Output

### SUPER SMALL OUTLINE PACKAGE



**MPXH6115A6U  
 CASE 1317**

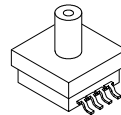

**MPXH6115AC6U  
 CASE 1317A**

### PIN NUMBER

|   |                  |   |     |
|---|------------------|---|-----|
| 1 | N/C              | 5 | N/C |
| 2 | V <sub>S</sub>   | 6 | N/C |
| 3 | Gnd              | 7 | N/C |
| 4 | V <sub>out</sub> | 8 | N/C |

NOTE: Pins 1, 5, 6, 7, and 8 are internal device connections. Do not connect to external circuitry or ground. Pin 1 is denoted by the chamfered corner of the package.

### SMALL OUTLINE PACKAGE

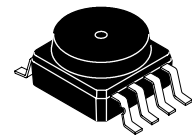

**MPXA6115A6U  
 CASE 482**

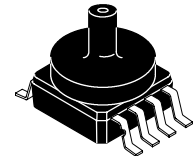

**MPXA6115AC6U  
 CASE 482A**

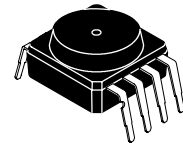

**MPXV5004G7U  
 CASE 482B**

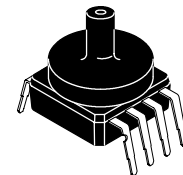

**MPXV5004GC7U  
 CASE 482C**

### PIN NUMBER

|   |                  |   |     |
|---|------------------|---|-----|
| 1 | N/C              | 5 | N/C |
| 2 | V <sub>S</sub>   | 6 | N/C |
| 3 | Gnd              | 7 | N/C |
| 4 | V <sub>out</sub> | 8 | N/C |

NOTE: Pins 1, 5, 6, 7, and 8 are internal device connections. Do not connect to external circuitry or ground. Pin 1 is denoted by the notch in the lead.

# Freescale Semiconductor, Inc.

## MAXIMUM RATINGS<sup>(1)</sup>

| Parametrics  | Symbol           | Value         | Units |
|--|------------------|---------------|-------|
| Maximum Pressure (P1 > P2)                                   | P <sub>max</sub> | 400           | kPa   |
| Storage Temperature  | T <sub>stg</sub> | -40° to +125° | °C    |
| Operating Temperature  | T <sub>A</sub>   | -40° to +125° | °C    |
| Output Source Current @ Full Scale Output <sup>(2)</sup>     | I <sub>o+</sub>  | 0.5           | mAdc  |
| Output Sink Current @ Minimum Pressure Offset <sup>(2)</sup> | I <sub>o-</sub>  | -0.5          | mAdc  |

### NOTES:

- Exposure beyond the specified limits may cause permanent damage or degradation to the device.
- Maximum Output Current is controlled by effective impedance from V<sub>out</sub> to Gnd or V<sub>out</sub> to V<sub>S</sub> in the application circuit.

## OPERATING CHARACTERISTICS (V<sub>S</sub> = 5.0 Vdc, T<sub>A</sub> = 25°C unless otherwise noted, P1 > P2.)

| Characteristic   | Symbol           | Min   | Typ   | Max   | Unit              |
|--|------------------|-------|-------|-------|-------------------|
| Pressure Range   | P <sub>OP</sub>  | 15    | —     | 115   | kPa               |
| Supply Voltage <sup>(1)</sup>  | V <sub>S</sub>   | 4.75  | 5.0   | 5.25  | Vdc               |
| Supply Current   | I <sub>o</sub>   | —     | 6.0   | 10    | mAdc              |
| Minimum Pressure Offset <sup>(2)</sup><br>@ V <sub>S</sub> = 5.0 Volts | V <sub>off</sub> | 0.133 | 0.200 | 0.268 | Vdc               |
| Full Scale Output <sup>(3)</sup><br>@ V <sub>S</sub> = 5.0 Volts       | V <sub>FSO</sub> | 4.633 | 4.700 | 4.768 | Vdc               |
| Full Scale Span <sup>(4)</sup><br>@ V <sub>S</sub> = 5.0 Volts         | V <sub>FSS</sub> | 4.433 | 4.500 | 4.568 | Vdc               |
| Accuracy <sup>(5)</sup>  | —                | —     | —     | ±1.5  | %V <sub>FSS</sub> |
| Sensitivity  | V/P              | —     | 45    | —     | mV/kPa            |
| Response Time <sup>(6)</sup>   | t <sub>R</sub>   | —     | 1.0   | —     | ms                |
| Warm-Up Time <sup>(7)</sup>  | —                | —     | 20    | —     | ms                |
| Offset Stability <sup>(8)</sup>  | —                | —     | ±0.25 | —     | %V <sub>FSS</sub> |

### NOTES:

- Device is ratiometric within this specified excitation range.
- Offset (V<sub>off</sub>) is defined as the output voltage at the minimum rated pressure.
- Full Scale Output (V<sub>FSO</sub>) is defined as the output voltage at the maximum or full rated pressure.
- Full Scale Span (V<sub>FSS</sub>) is defined as the algebraic difference between the output voltage at full rated pressure and the output voltage at the minimum rated pressure.
- Accuracy is the deviation in actual output from nominal output over the entire pressure range and temperature range as a percent of span at 25°C due to all sources of error including the following:
  - Linearity: Output deviation from a straight line relationship with pressure over the specified pressure range.
  - Temperature Hysteresis: Output deviation at any temperature within the operating temperature range, after the temperature is cycled to and from the minimum or maximum operating temperature points, with zero differential pressure applied.
  - Pressure Hysteresis: Output deviation at any pressure within the specified range, when this pressure is cycled to and from minimum or maximum rated pressure at 25°C.
  - TcSpan: Output deviation over the temperature range of 0° to 85°C, relative to 25°C.
  - TcOffset: Output deviation with minimum pressure applied, over the temperature range of 0° to 85°C, relative to 25°C.
- Response Time is defined as the time for the incremental change in the output to go from 10% to 90% of its final value when subjected to a specified step change in pressure.
- Warm-up Time is defined as the time required for the product to meet the specified output voltage after the pressure has been stabilized.
- Offset Stability is the product's output deviation when subjected to 1000 cycles of Pulsed Pressure, Temperature Cycling with Bias Test.

# Freescale Semiconductor, Inc.

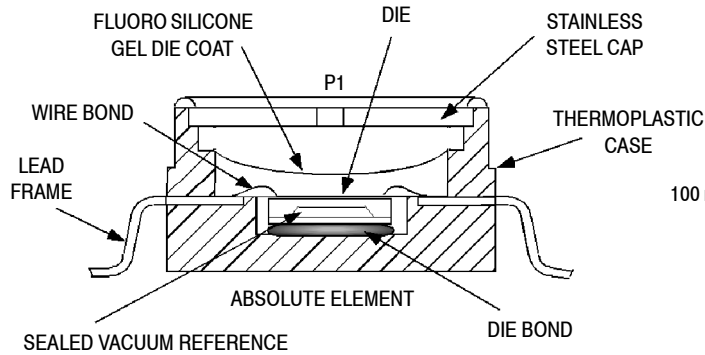

**Figure 2. Cross Sectional Diagram SSOP**  
(not to scale)

Figure 2 illustrates the absolute sensing chip in the basic Super Small Outline chip carrier (Case 1317).

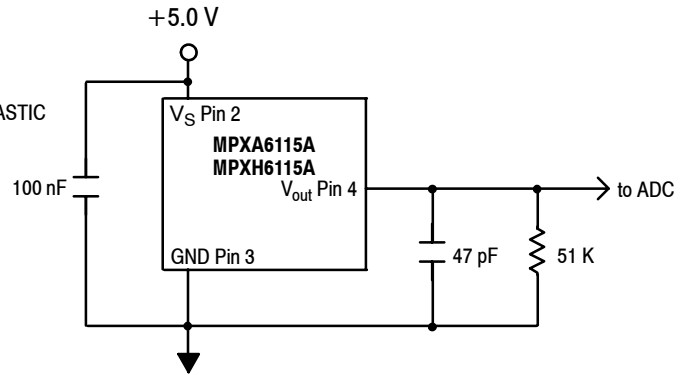

**Figure 3. Typical Application Circuit**  
(Output Source Current Operation)

Figure 3 shows a typical application circuit (output source current operation).

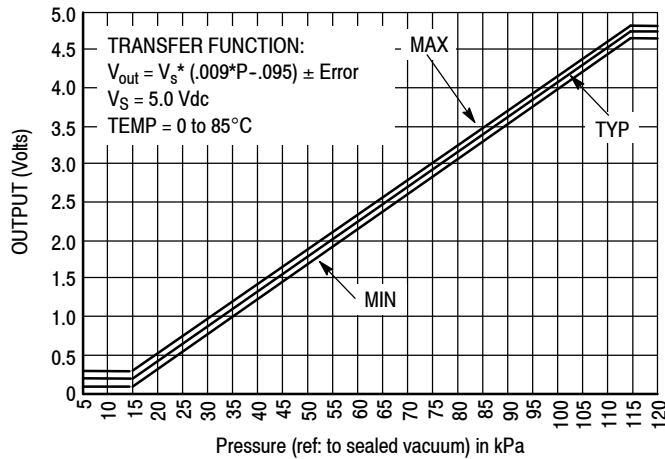

**Figure 4. Output versus Absolute Pressure**

Figure 4 shows the sensor output signal relative to pressure input. Typical minimum and maximum output curves are shown for operation over 0 to 85°C temperature range. The output will saturate outside of the rated pressure range.

A fluorosilicone gel isolates the die surface and wire bonds from the environment, while allowing the pressure signal to be transmitted to the silicon diaphragm. The

MPXA6115A/MPXH6115A series pressure sensor operating characteristics, internal reliability and qualification tests are based on use of dry air as the pressure media. Media other than dry air may have adverse effects on sensor performance and long-term reliability. Contact the factory for information regarding media compatibility in your application.

# Freescale Semiconductor, Inc.

## Transfer Function (MPXA6115A/MPXH6115A)

**Nominal Transfer Value:**  $V_{out} = V_S \times (0.009 \times P - 0.095)$   
 $\pm$  (Pressure Error  $\times$  Temp. Factor  $\times 0.009 \times V_S$ )  
 $V_S = 5.0 \pm 0.25$  Vdc

## Temperature Error Band

MPXA6115A/MPXH6115A Series

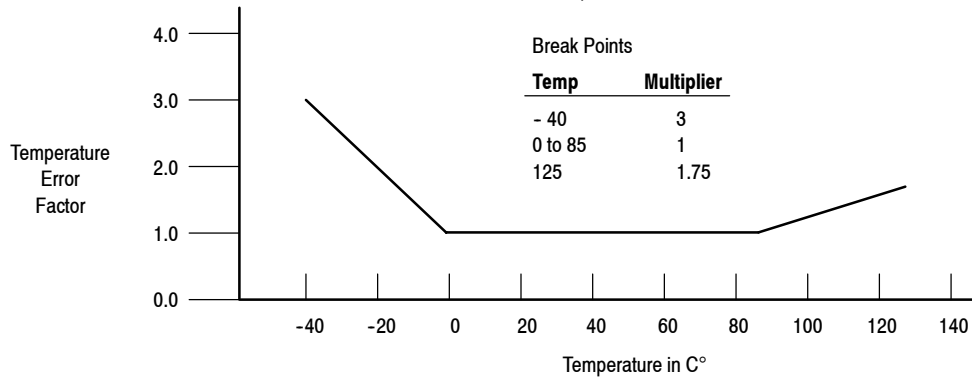

NOTE: The Temperature Multiplier is a linear response from 0°C to -40°C and from 85°C to 125°C

## Pressure Error Band

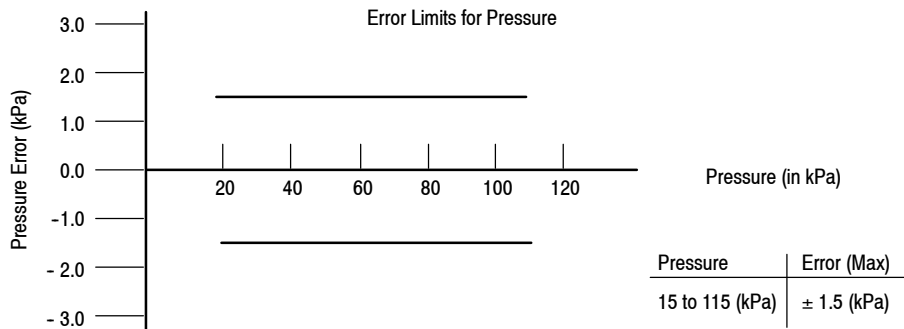

## ORDERING INFORMATION — SMALL OUTLINE PACKAGE

| Device Type    | Options                | Case No. | MPX Series Order No. | Packing Options | Marking   |
|----------------|------------------------|----------|----------------------|-----------------|-----------|
| Basic Element  | Absolute, Element Only | 482      | MPXA6115A6U          | Rails           | MPXA6115A |
|                | Absolute, Element Only | 482      | MPXA6115A6T1         | Tape and Reel   | MPXA6115A |
| Ported Element | Absolute, Axial Port   | 482A     | MPXA6115AC6U         | Rails           | MPXA6115A |
|                | Absolute, Axial Port   | 482A     | MPXA6115AC6T1        | Tape and Reel   | MPXA6115A |

## ORDERING INFORMATION — SUPER SMALL OUTLINE PACKAGE

| Device Type    | Options                | Case No. | MPX Series Order No. | Packing Options | Marking   |
|----------------|------------------------|----------|----------------------|-----------------|-----------|
| Basic Element  | Absolute, Element Only | 1317     | MPXH6115A6U          | Rails           | MPXH6115A |
|                | Absolute, Element Only | 1317     | MPXH6115A6T1         | Tape and Reel   | MPXH6115A |
| Ported Element | Absolute, Axial Port   | 1317A    | MPXH6115AC6U         | Rails           | MPXH6115A |
|                | Absolute, Axial Port   | 1317A    | MPXH6115AC6T1        | Tape and Reel   | MPXH6115A |

# Freescale Semiconductor, Inc.

## SURFACE MOUNTING INFORMATION

### MINIMUM RECOMMENDED FOOTPRINT FOR SMALL AND SUPER SMALL PACKAGES

Surface mount board layout is a critical portion of the total design. The footprint for the semiconductor package must be the correct size to ensure proper solder connection interface between the board and the package. With the correct pad geometry, the packages will self-align when subjected to

a solder reflow process. It is always recommended to fabricate boards with a solder mask layer to avoid bridging and/or shorting between solder pads, especially on tight tolerances and/or tight layouts.

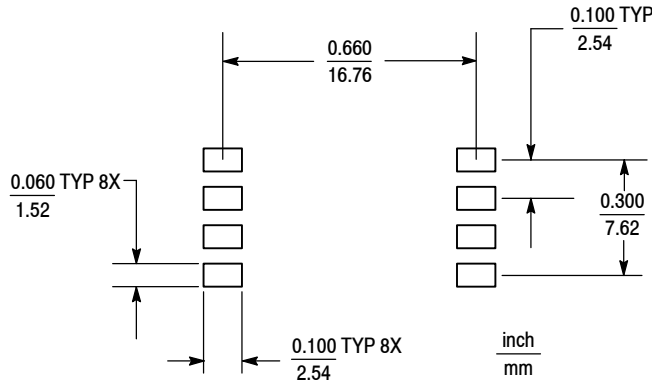

Figure 5. SOP Footprint (Case 482)

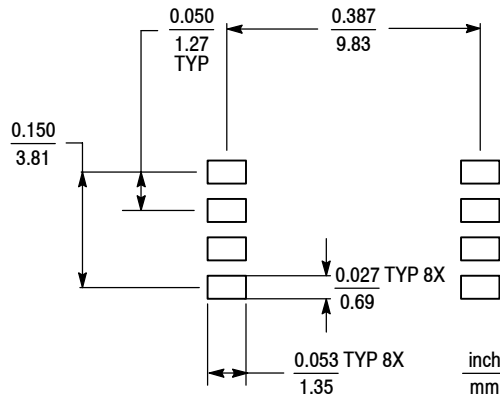

Figure 6. SSOP Footprint (Case 1317 and 1317A)

**NOTES**

**NOTES**

# Freescale Semiconductor, Inc.

## SMALL OUTLINE PACKAGE DIMENSIONS

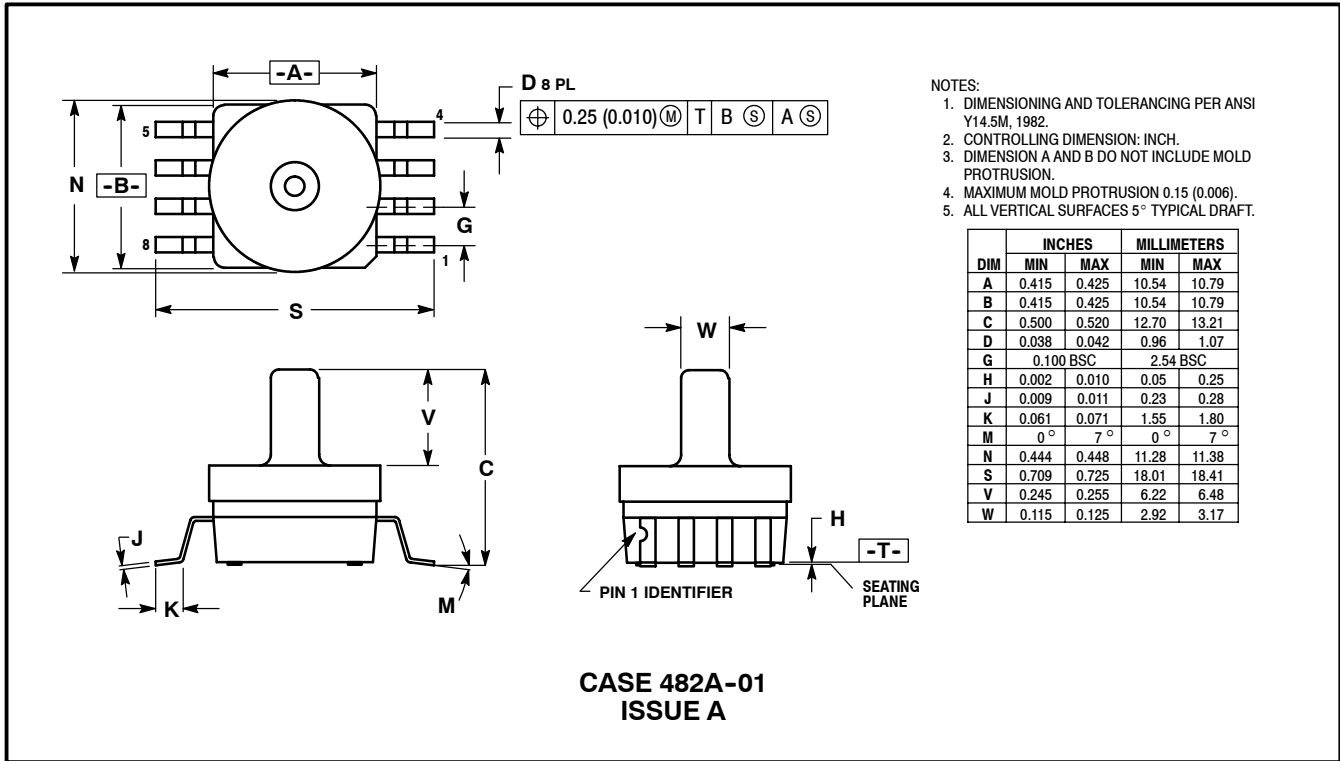
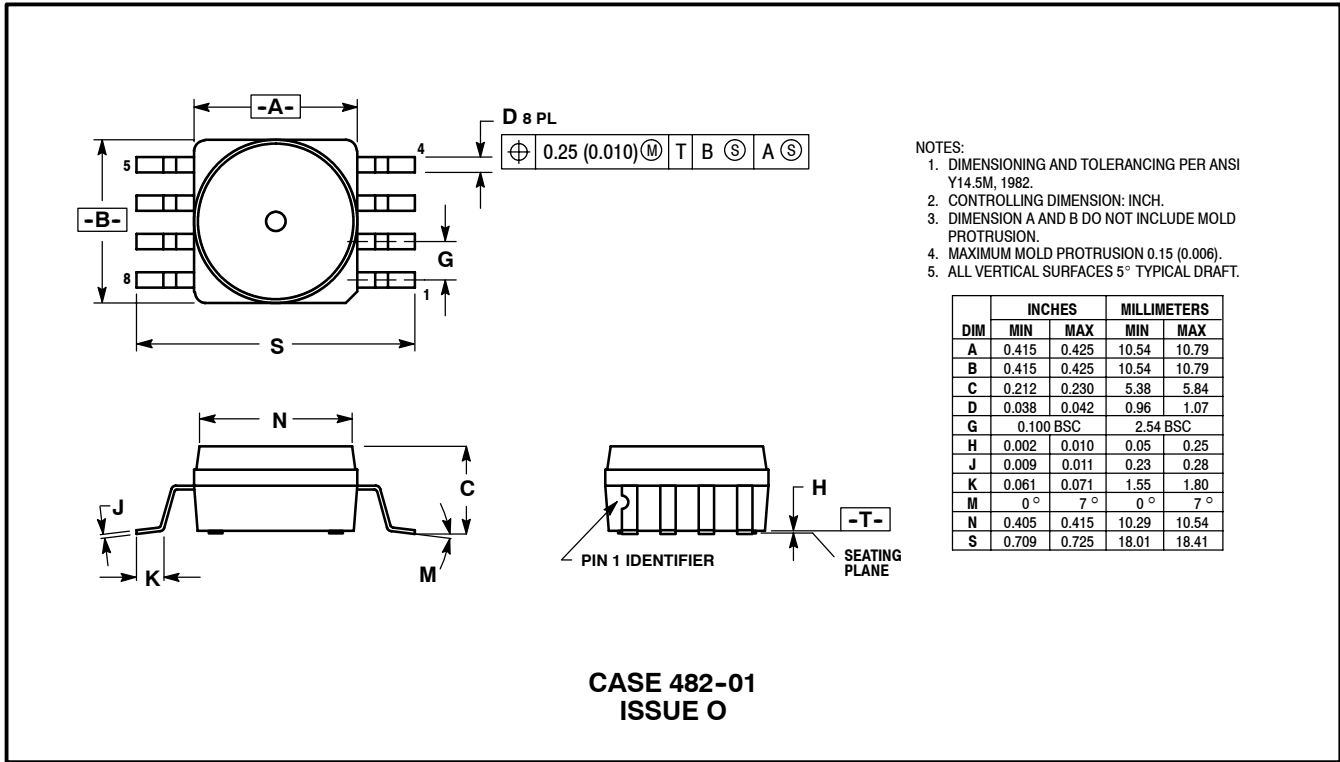





# Freescale Semiconductor, Inc.

## SUPER SMALL OUTLINE PACKAGE DIMENSIONS

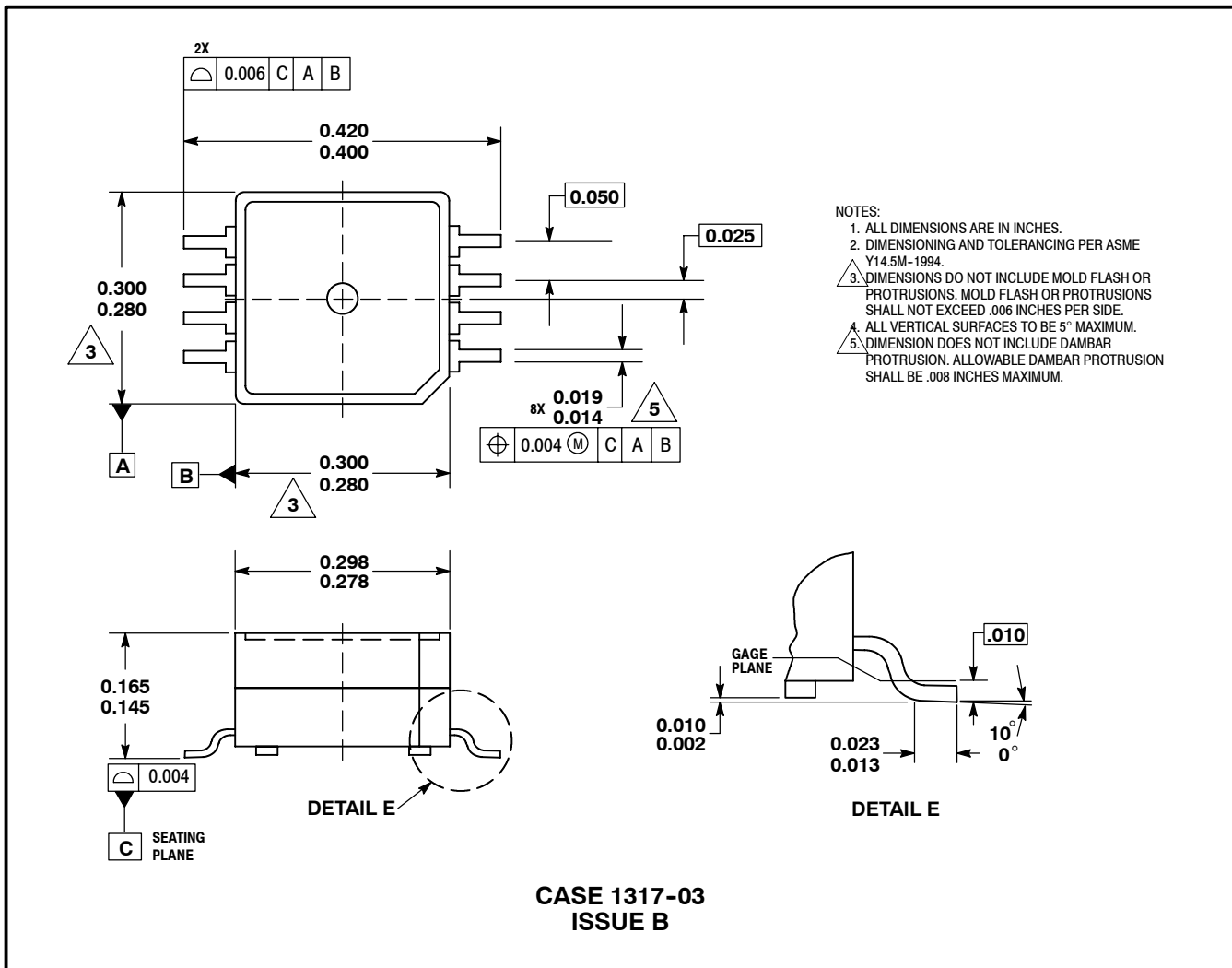

# Freescale Semiconductor, Inc.

## SUPER SMALL OUTLINE PACKAGE DIMENSIONS (CONTINUED)

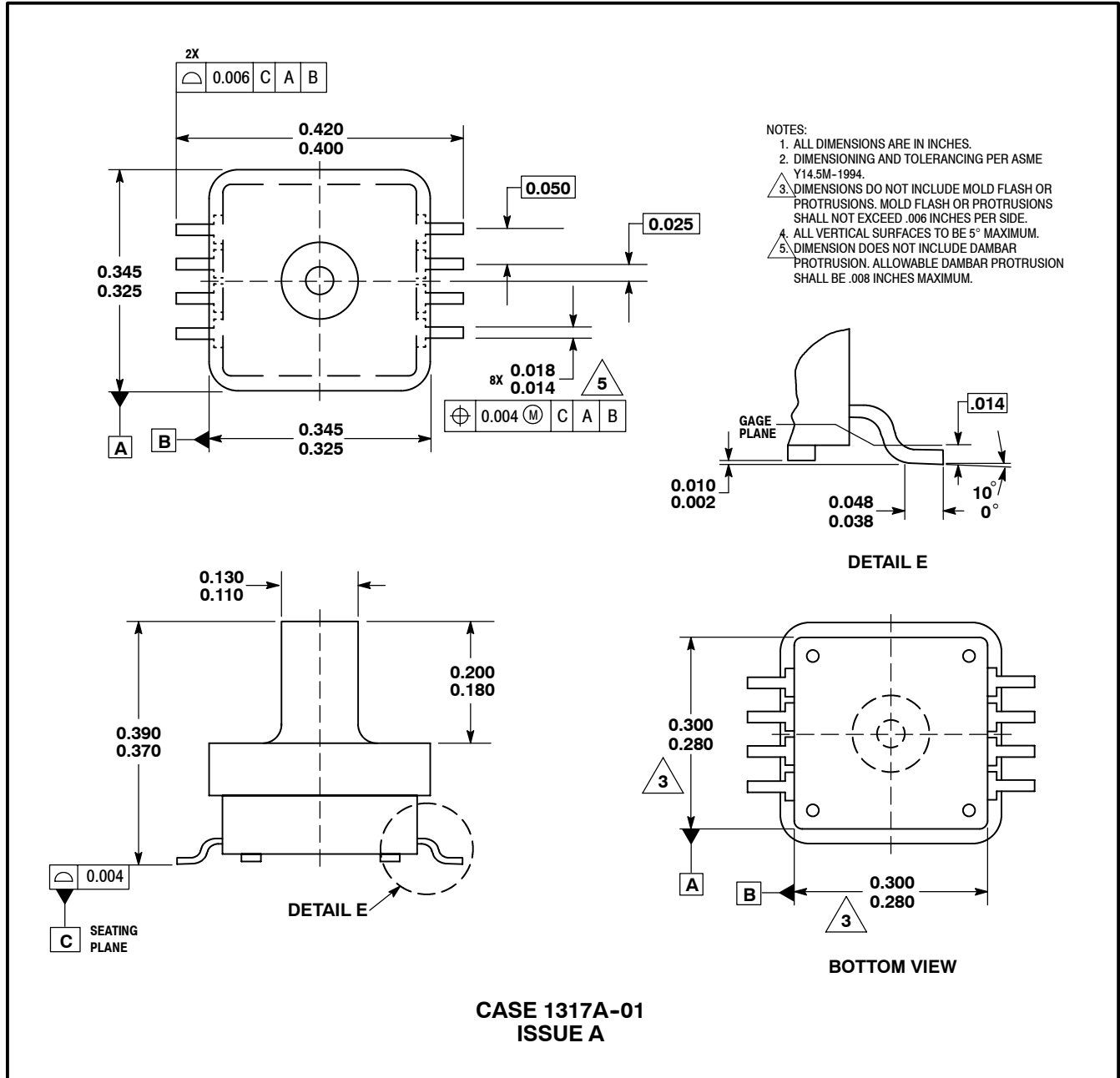

Information in this document is provided solely to enable system and software implementers to use Motorola products. There are no express or implied copyright licenses granted hereunder to design or fabricate any integrated circuits or integrated circuits based on the information in this document.

Motorola reserves the right to make changes without further notice to any products herein. Motorola makes no warranty, representation or guarantee regarding the suitability of its products for any particular purpose, nor does Motorola assume any liability arising out of the application or use of any product or circuit, and specifically disclaims any and all liability, including without limitation consequential or incidental damages. "Typical" parameters that may be provided in Motorola data sheets and/or specifications can and do vary in different applications and actual performance may vary over time. All operating parameters, including "Typicals", must be validated for each customer application by customer's technical experts. Motorola does not convey any license under its patent rights nor the rights of others. Motorola products are not designed, intended, or authorized for use as components in systems intended for surgical implant into the body, or other applications intended to support or sustain life, or for any other application in which the failure of the Motorola product could create a situation where personal injury or death may occur. Should Buyer purchase or use Motorola products for any such unintended or unauthorized application, Buyer shall indemnify and hold Motorola and its officers, employees, subsidiaries, affiliates, and distributors harmless against all claims, costs, damages, and expenses, and reasonable attorney fees arising out of, directly or indirectly, any claim of personal injury or death associated with such unintended or unauthorized use, even if such claim alleges that Motorola was negligent regarding the design or manufacture of the part.

MOTOROLA and the Stylized M Logo are registered in the US Patent and Trademark Office. All other product or service names are the property of their respective owners. Motorola, Inc. is an Equal Opportunity/Affirmative Action Employer.

© Motorola Inc. 2003

#### HOW TO REACH US:

**USA/EUROPE/LOCATIONS NOT LISTED:**  
Motorola Literature Distribution  
P.O. Box 5405, Denver, Colorado 80217  
1-800-521-6274 or 480-768-2130

**JAPAN:** Motorola Japan Ltd.; SPS, Technical Information Center,  
3-20-1, Minami-Azabu, Minato-ku, Tokyo 106-8573, Japan  
81-3-3440-3569

**ASIA/PACIFIC:** Motorola Semiconductors H.K. Ltd.; Silicon Harbour Centre,  
2 Dai King Street, Tai Po Industrial Estate, Tai Po, N.T., Hong Kong  
852-26668334

**HOME PAGE:** <http://motorola.com/semiconductors>



**MOTOROLA**

**For More Information On This Product,  
Go to: [www.freescale.com](http://www.freescale.com)**

**MPXA6115A**