

EVALUATION BOARD - INITIAL RELEASE

GENERAL DESCRIPTION

The EV0062 is an evaluation board designed to drive up to four (4) white LEDs in series. The board is based on MPS' MP1541 SOT23 current mode step up converter. The MP1541 is intended for small, low power applications. The MP1541 switches at 1.3MHz and allows the use of tiny, low cost capacitors and inductors 2mm or less in height. Internal soft start results in small inrush current and extends the battery life. The MP1541 operates from an input voltage as low as 2.5V and can generate 12V at up to 200mA from a 5V supply.

The MP1541 includes under-voltage lockout, current limiting and thermal overload protection preventing damage in the event of an output overload. The MP1541 is available in a small 5-lead TSOT23 package.

ELECTRICAL SPECIFICATION

Parameter	Symbol	Value	Units
Supply Voltage	V_{IN}	2.5 – 6	V
LED Current (Torch)	I_{OUT1}	20	mA
LED Current (Flash)	I_{OUT2}	100	mA

FEATURES

- On Board Power MOSFET
- Uses Tiny Capacitors and Inductors
- 1.3MHz Fixed Switching Frequency
- Internally Compensated
- Internal Soft Start
- Operates with Input Voltage as Low as 2.5V and Output Voltage as High as 22V
- 12V at 200mA from 5V Input
- UVLO, Thermal Shutdown
- Internal Current Limit
- Available in a TSOT23-5 Package

APPLICATIONS

- Camera Phone Flash
- Handheld Computers and PDAs
- Digital Still and Video Cameras
- External Modems
- Small LCD Displays
- White LED Driver

MPS, "MPS", "Monolithic Power Systems", and "The Future of Analog IC Technology" are Registered Trademarks of Monolithic Power Systems, Inc.

EV0062 EVALUATION BOARD

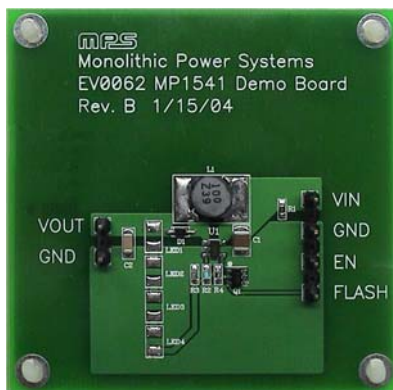

(2.5"X x 2.5"Y x 0.8"Z)

Board Number	MPS IC Number
EV0062 Rev. B	MP1541

Waveform in Flash Mode

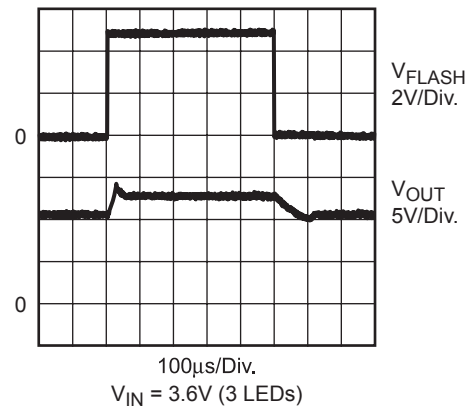

EV0062_MP1541_TAC_EC01

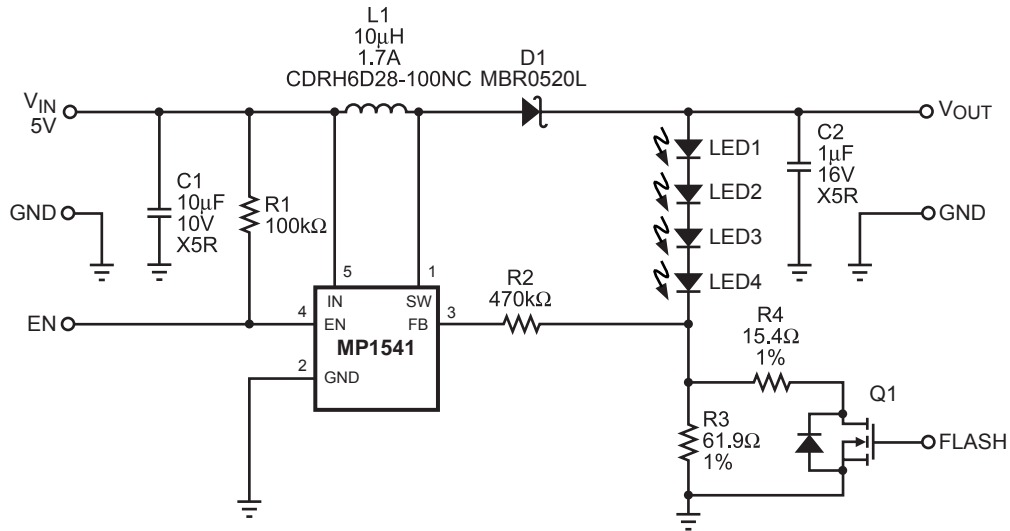
EVALUATION BOARD SCHEMATIC

EV0062_MP1541_SCH01

EV0062 BILL OF MATERIALS

Qty	Ref	Description	Package	Manufacturer P/N	Distributor P/N ⁽¹⁾
1	C1	Ceramic Capacitor, 10uF, 10V, X5R	1210	Panasonic: ECJ-4YB1A106K	PCC2170CT-ND
1	C2	Ceramic Capacitor, 1uF, 16V, X5R	1206	Panasonic: ECJ-3YB1C105K	PCC1882CT-ND
1	D1	Schottky Diode, 0.5A, 20V	SOD-123	Fairchild: MBR0520L	MBR0520LCT-ND
1	L1	Inductor, 10uH, 1.7A		Sumida: CDRH6D28-100NC	
1	Q1	N-Channel Mosfet, 60V, 3A	SOT23-6	Zetex: ZXMN6A08E6TA	ZXMN6A08E6CT-ND
1	U1	1.3MHz Boost Converter	SOT23-5	MPS: MP1541	
1	R1	Resistor, 100kΩ, 5%	0603	Panasonic: ERJ-6ENF1003V	P100KCCT-ND
1	R2	Resistor, 470kΩ, 5%	0603	Panasonic: ERJ-6GEYJ474V	P470KACT-ND
1	R3	Resistor, 61.9Ω, 1%	0603	Panasonic: ERJ-6ENF61R9V	P61.9CCT-ND
1	R4	Resistor, 15.4Ω, 1%	0603	Panasonic: ERJ-6ENF15R4V	P15.4CCT-ND
1	LED1	Flash LED ⁽²⁾			
1	LED2	Flash LED ⁽²⁾			
1	LED3	Flash LED ⁽²⁾			
1	LED4	Flash LED ⁽²⁾			

Note

- 1) Distributor: Digikey
- 2) Not included with board.

PRINTED CIRCUIT BOARD LAYOUT

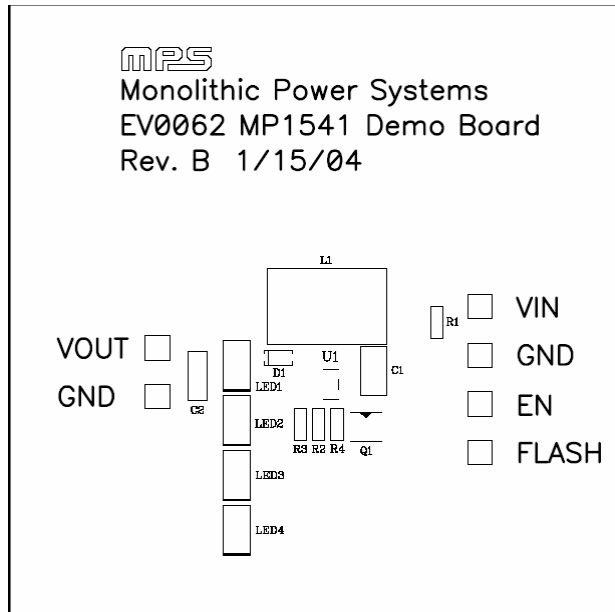

Figure 1—Top Silk Layer

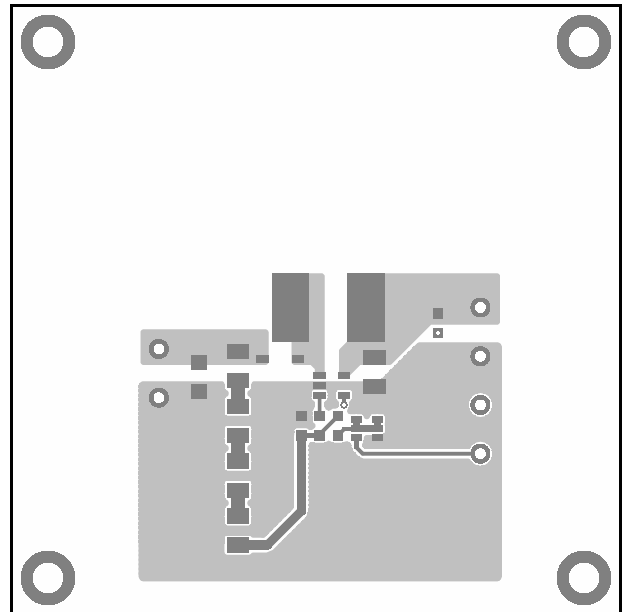

Figure 2—Top Layer

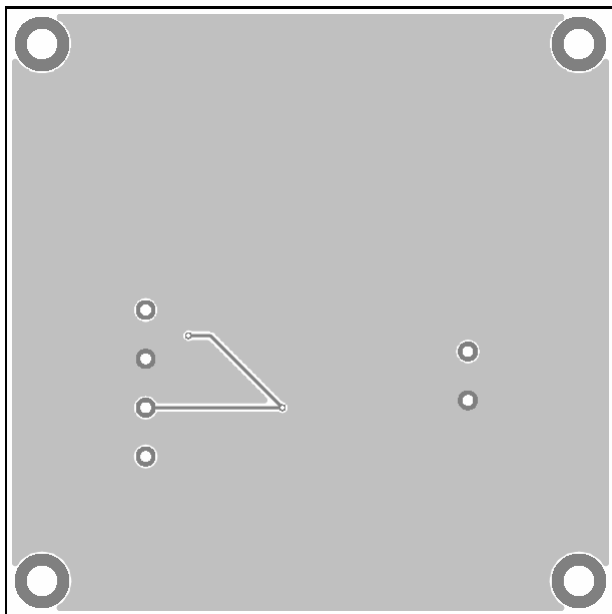

Figure 3— Bottom Layer

QUICK START GUIDE

1. Connect LEDs to LED1 – LED4 terminals.
2. Preset Power Supply to 2.5V – 6V.
3. Turn Off Power Supply.
4. Connect Power Supply terminals to:
 - a. Positive (+): VIN
 - b. Negative (-): GND
5. Turn Power Supply On after making connections.
6. The MP1541 is automatically enabled on the demo board once V_{IN} is applied.
7. Drive FLASH of Q1 with a pulsed signal (3V or above for High, 0V for Low) to switch between two (2) LED currents.
8. I_{OUT1} is set to 20mA on the board.
9. I_{OUT2} is set to 100mA on the board.

NOTICE: MPS believes the information in this document to be accurate and reliable. However, it is subject to change without notice. Contact MPS for current specifications. MPS encourages users of its products to ensure that third party Intellectual Property rights are not infringed upon when integrating MPS products into any application. MPS cannot assume any legal responsibility for any said applications.