

High Tuning Ratio Silicon Hyperabrupt Varactor Diode

MA4ST1103-1141T
V1

Features

- Lower Series Resistance < 0.7 Ω
- Higher Capacitance Ratio > 3.5:1
- Higher Tuning Voltage < 18 V
- Tape and Reel Surface Mount Packaging

Description and Applications

M/A-COM's MA4ST1103-1141T is a highly repeatable, ion-implanted, hyperabrupt silicon tuning varactor in a cost effective surface mount package. This varactor is designed for a higher capacitance ratio, a higher tuning voltage, with a respectable Q value for wider band VCO applications.

SOD-323 Plastic Package

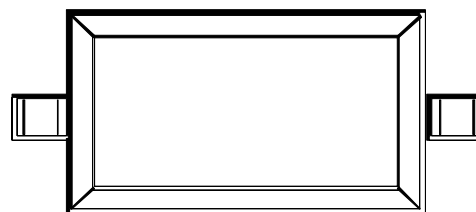

Ordering Information

Part Number	Configuration	Package
MA4ST1103-1141T	Single	SOD-323

Absolute Maximum Ratings @ $T_A = +25^\circ C$ (Unless Otherwise Noted)¹

Parameter	Absolute Maximum
Reverse Voltage	22 V
Forward Current	20 mA
Power Dissipation	250 mW
Operating Temperature	-55 °C to +125 °C
Storage Temperature	-55 °C to +125 °C

1. Operation of this device above any one of these parameters

Technical Parasitic Information

Package Type	Package Cp (pF)	Package Ls (nH)
SOD-323	0.11	1.2

**High Tuning Ratio
Silicon Hyperabrupt Varactor Diode**

**MA4ST1103-1141T
V1**

Electrical Specifications @ $T_A = +25\text{ }^\circ\text{C}$

Parameter	Condition	Min	Typ	Max	Unit
Reverse Current (I_R)	$V_r = 18$ Volts			20	nA
Capacitance (C_T)	$V_r = 1$ V, 1 MHz	20.9	23.3	25.7	pF
Capacitance (C_{TR})	$C_T(1\text{ V})/C_T(3\text{ V})$	1.3		1.6	
Capacitance Ratio (C_{TR})	$C_T(1\text{ V})/C_T(9\text{ V})$	3.5		4.5	
Series Resistance (R_s)	$V_r = 1$ V, 500 MHz		0.65	0.85	Ω
Breakdown Voltage (V_B)	$I_R = 10\text{ }\mu\text{A}$	22			V

Typical Performance Curves

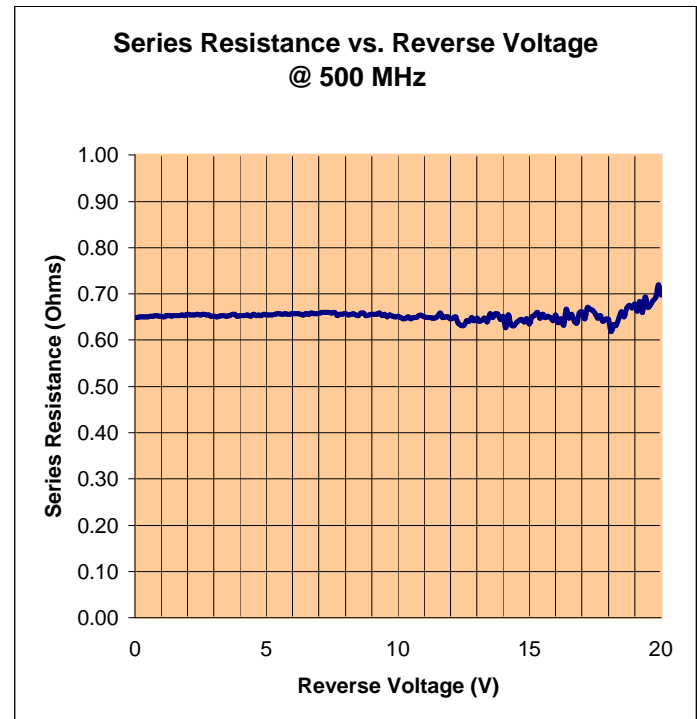
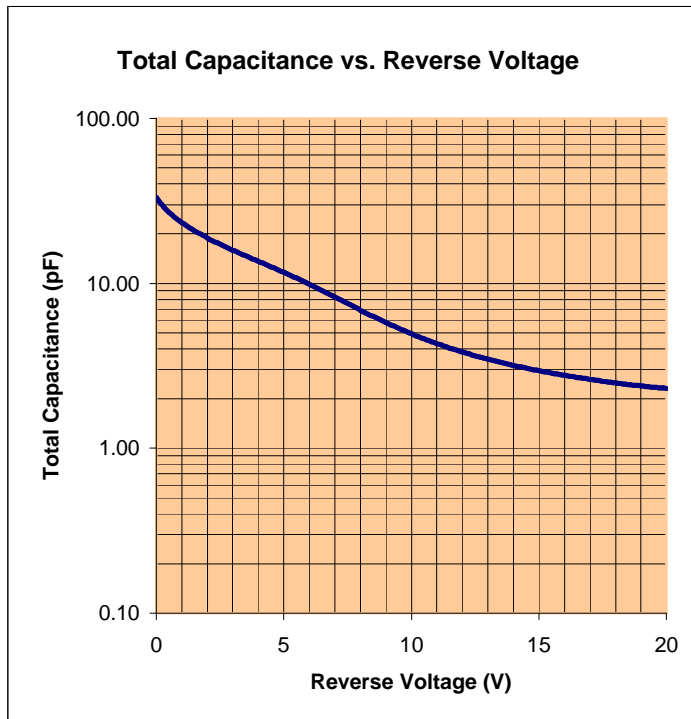

**High Tuning Ratio
Silicon Hyperabrupt Varactor Diode**

**MA4ST1103-1141T
V1**

Typical Capacitance Values

V_R (V)	MA4ST1103
	Ct (pF)
0.0	33.15
0.5	26.95
1.0	23.3
2.0	18.86
3.0	15.9
4.0	13.62
5.0	11.66
10.0	4.94
15.0	2.95
20.0	2.31

**SOD-323
Case Style 1141**

DIM.	INCHES		MILLIMETERS	
	MIN.	MAX.	MIN.	MAX.
A	—	0.043	—	1.1
B	—	0.004	—	0.1
C	—	0.008	—	0.2
D	0.010	0.016	0.25	0.4
E	0.003	0.006	0.08	0.15
F	0.063	0.075	1.6	1.9
G	0.045	0.057	1.15	1.45
H	0.091	0.106	2.3	2.7

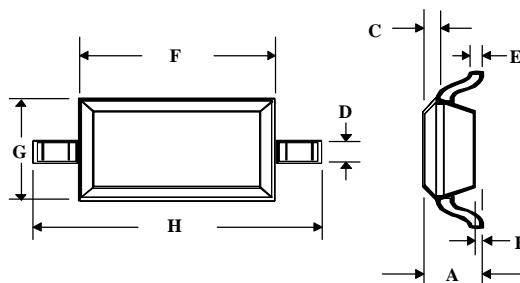

Spice Model

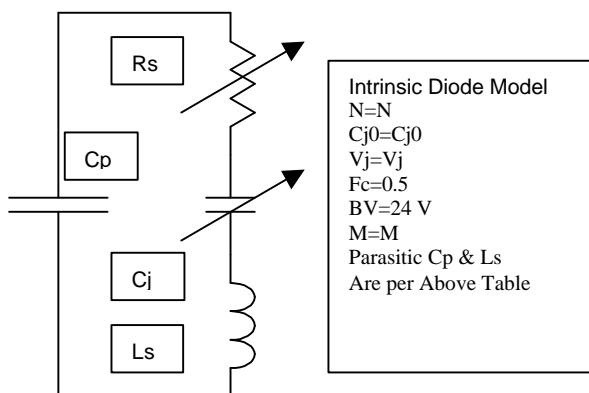

Part Number	N	CJO (pF)	Vj (V)	M
MA4ST1103	0.994	28.1	65.4	15