

# M54543AFP

Bi-DIRECTIONAL MOTOR DRIVER  
WITH BRAKE FUNCTION AND THERMAL SHUT DOWN FUNCTION

## DESCRIPTION

The M54543AFP is a semiconductor integrated circuit that is capable of directly driving a smallsize bi-directional motor rotating in both forward and reverse directions.

## FEATURES

- Wide range of operating voltage ( $V_{CC}=4 - 15V$ )
- Possible direct driving with TTL, PMOS and CMOS IC outputs
- Small outline (10-pin SOP)
- Low output saturation voltage (large voltage across motors)
- Built-in clamp diode
- Large output current drive ( $I_{O(max)} = \pm 700mA$ )
- Provided with brake function
- Built-in thermal shutdown protection circuit

## APPLICATION

Sound equipment such as tape deck and radio cassette, VTR, and other general consumer appliances

## PIN CONFIGURATION (TOP VIEW)

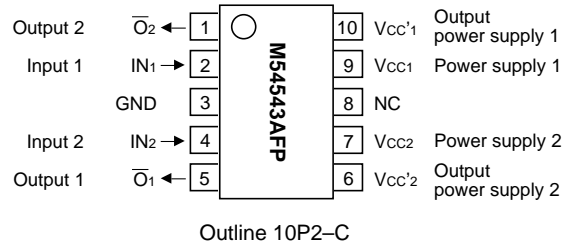

NC : no connection

## BLOCK DIAGRAM

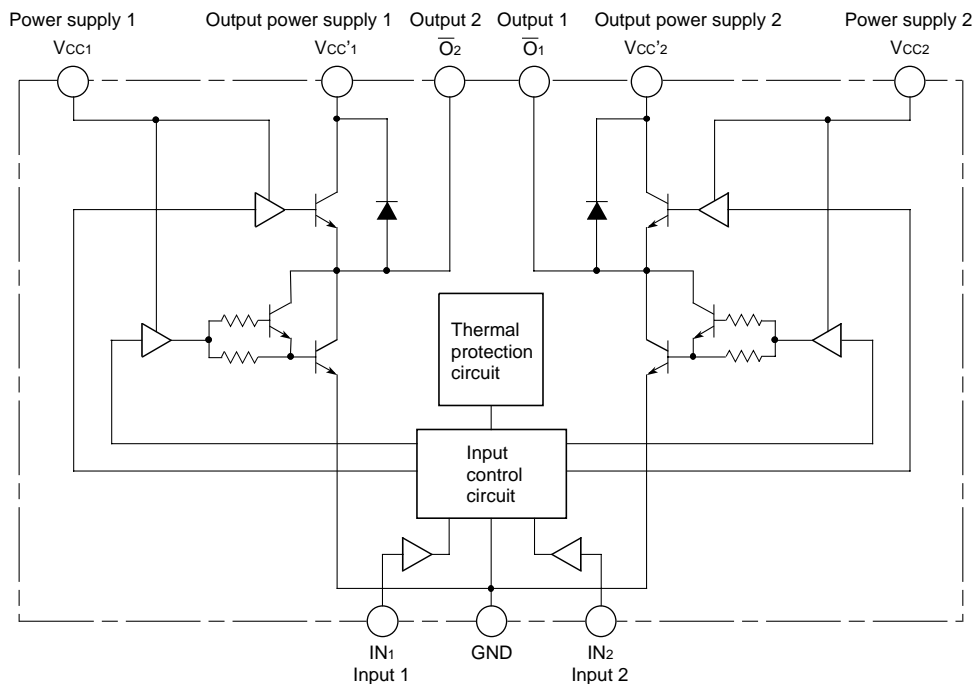

# M54543AFP

## Bi-DIRECTIONAL MOTOR DRIVER WITH BRAKE FUNCTION AND THERMAL SHUT DOWN FUNCTION

### FUNCTION

The M54543AFP is an IC for driving a smallsize bi-directional motor that rotates in both forward and reverse directions. When both inputs 1 and 2 are set to low-level, outputs 1 and 2 are set to "OFF". When input 1 is set to high-level and input 2 is set to low-level, output 1 is set to high-level and output 2 is set to low-level (forward rotation status). When input 1 is set to low-level and input 2 is set to high-level, output 1 is set to low-level and output 2 is set to high-level (reverse rotation). When both inputs 1 and 2 are set to high-level, both outputs 1 and 2 are set to low-level (brake status). The power supply (Vcc) to the control circuit and the power supply (Vcc') for output are independently provided. The rotating speed of the motor can be therefore changed by using Vcc and Vcc' as

different power supplies and by making Vcc or Vcc' variable. In addition, built-in thermal protection circuit protects the IC from thermal destruction in case of abnormal condition such as motor blocking.

### LOGIC TRUTH TABLE

Input		Output		Remarks
IN <sub>1</sub>	IN <sub>2</sub>	$\bar{O}_1$	$\bar{O}_2$	
L	L	"OFF" state	"OFF" state	No operation of IC
H	L	H	L	ex Forward rotation
L	H	L	H	ex Reverse rotation
H	H	L	L	Brake

### ABSOLUTE MAXIMUM RATINGS (Ta=25°C, unless otherwise noted)

Symbol	Parameter	Conditions	Ratings	Unit
Vcc(1)	Supply voltage (1)		-0.5 – +16	V
Vcc'(1)	Output supply voltage (1)		-0.5 – +16	V
Vi	Input voltage		0 – Vcc	V
Vo	Output voltage		-0.5 – Vcc+2.5	V
Io(max)	Allowable motor rush current	tcc=10ms : cycle time 0.2Hz or less	±700	mA
Io(1)	Continuous output current(1)		±150	mA
Pd	Power dissipation	Ta=75°C	200	mW
Topr	Operating temperature		-10 – 75	°C
Tstg	Storage temperature		-55 – 75	°C

### RECOMMENDED OPERATING CONDITION (Ta=25°C, unless otherwise noted)

Symbol	Parameter	Limits			Unit	
		Min.	Typ.	Max.		
Vcc	Supply voltage	4	12	15	V	
Io	Continuous output current			±100	mA	
VIH	"H" input voltage	2	5	Vcc	V	
VIL	"L" input voltage	0		0.4	V	
tB	Motor braking interval	10	100		ms	
tj(shut)	Thermal shutdown temperature	However, indicates the junction temperature only in the case of Vcc≥7V.			150	°C

### ELECTRICAL CHARACTERISTICS (Ta=25°C, unless otherwise noted)

Symbol	Parameter	Test conditions	Limits			Unit
			Min.	Typ.	Max.	
Io(leak)	Output leak current	Vcc=Vcc'=16V Vi1=Vi2=0V			100	μA
VOH	"H" output saturation voltage	Vcc=Vcc'=12V Vi1=0V, Vi2=2V or Vi1=2V, Vi2=0V				V
VOL	"L" output saturation voltage	Vcc=Vcc'=12V Vi1=2V, Vi2=0V or Vi1=0V, Vi2=2V				V
						V
VO1-02	Voltage between outputs (1) and (2) (Voltage across motors)	Vcc=Vcc'=12V, Vi1=2V, Vi2=0V or Vi1=0V, Vi2=2V Io=±100mA, VO1-VO2=VOH1-VOL2	9.6			V
Ii	Input current	Vcc=Vcc'=12V, Vi=2V	50		120	μA
Icc	Supply current	Vcc=Vcc'=12V Output open				mA

# M54543AFP

Bi-DIRECTIONAL MOTOR DRIVER  
WITH BRAKE FUNCTION AND THERMAL SHUT DOWN FUNCTION

## TYPICAL CHARACTERISTICS

Thermal Derating (Absolute Maximum Rating)

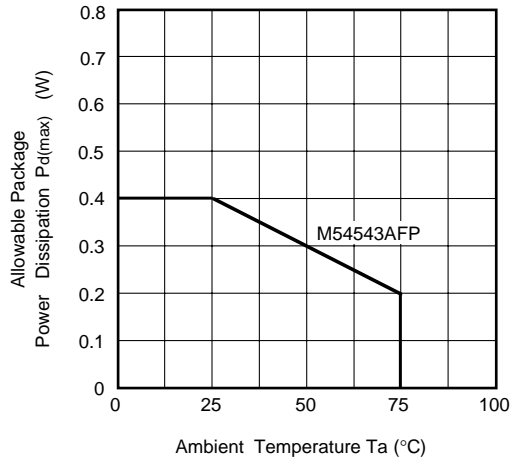

"H" Output Saturation Characteristics

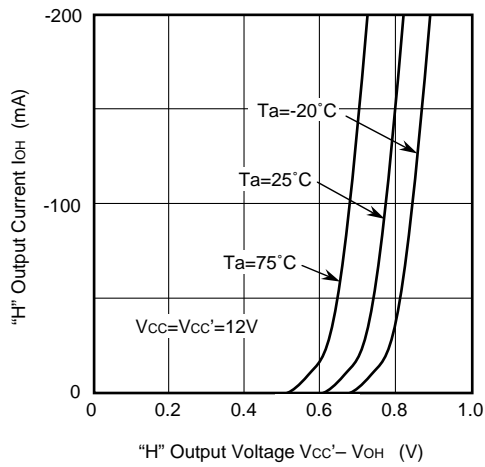

"L" Output Saturation Characteristics

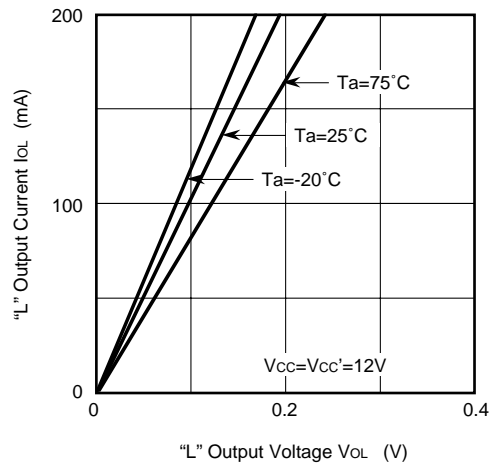

# M54543AFP

## Bi-DIRECTIONAL MOTOR DRIVER WITH BRAKE FUNCTION AND THERMAL SHUT DOWN FUNCTION

### CAUTIONS

Since the thermal protection function of this IC may not work in abnormal status (oscillation, low supply voltage, output short-circuit, etc.), check the operation in the IC installation status when using this function.

When the motor back electromotive force is large with the brakes applied, for example, malfunction may occur in internal parasitic Di. If flyback current of 1A or more flows, add Schottky Di to the portion between the output and the GND.

When the IC is used at a high speed for PWM, etc., note that switching of output results in delay of approx. 10 $\mu$ s.

### APPLICATION EXAMPLES

1) When Vcc and Vcc' are used as the same power supply

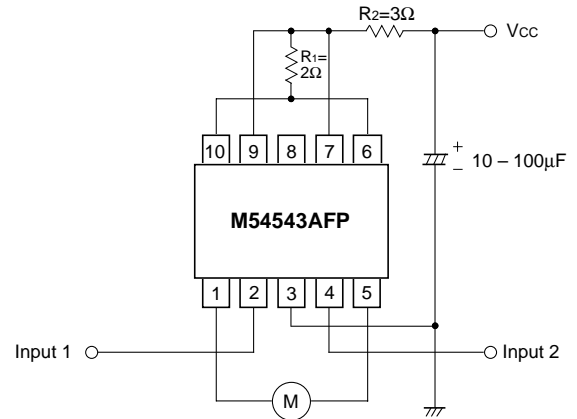

2) When Vcc is used as a fixed power supply and Vcc' is used as a variable power supply

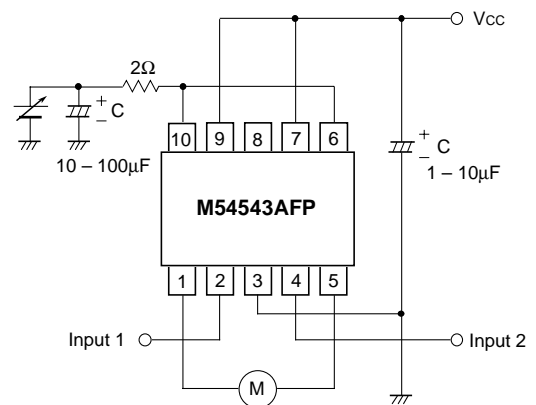

3) When Vcc is used as a variable power supply and Vcc' is used as a fixed power supply

