

SANYO	No.3664A	LB1657M
	2-Phase Stepping Motor Driver	

The LB1657M is a dual bridge driver IC suited for use in 2-phase bipolar stepping motor driver for FDD (3 to 5.25 inches) head actuator. The maximum driver current × voltage is 0.33A × 12V/bridge.

Features

- Power save function
- $\phi 1, \phi 2$ direction inputs are used to make driver output selection.
- Low saturation voltage
- Low current dissipation
- Direct controllable from MPU due to low input current
- Input level : TTL, LSTTL, 5V CMOS compatible
- On-chip thermal shutdown (TSD) circuit

Absolute Maximum Ratings at Ta = 25°C

			unit
Logic Section Supply Voltage	V _{CC}	7	V
Seeking Supply Voltage	V _S	15	V
Input Voltage	V _I	0 to V _{CC}	V
Peak Seeking Current	I _{O peak}	500	mA
Continuous Seeking Current	I _{OS}	330	mA
Allowable Power Dissipation	P _{d max}	0.9	W
Operating Temperature	T _{opr}	-20 to +70	°C
Storage Temperature	T _{stg}	-55 to +125	°C

Allowable Operating Conditions at Ta = 25°C

		min	typ	max	unit
Logic Section Supply Voltage	V _{CC}	4.5	5.0	5.5	V
Seeking Supply Voltage	V _S	10.2	12.0	13.8	V

Package Dimensions 3097
(unit: mm)

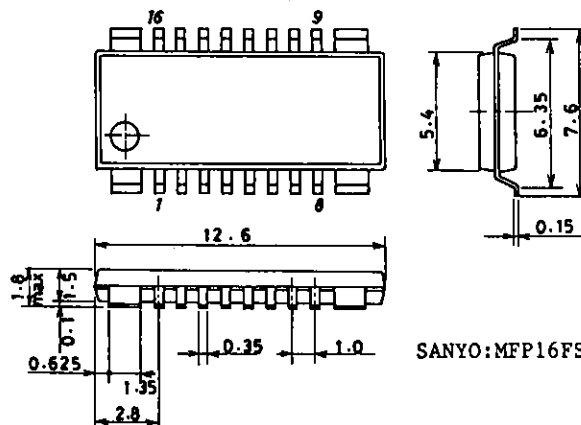
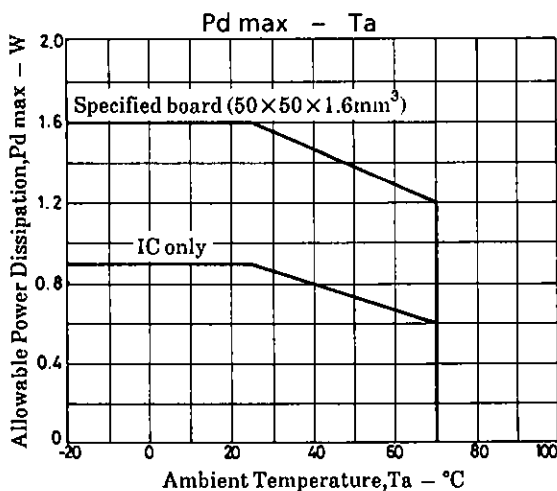

LB1657M

Electrical Characteristics at $T_a = 25^\circ\text{C}, V_{CC} = 5\text{V}, V_{S2} = 5\text{V}, V_{S1} = 12\text{V}$				min	typ	max	unit
Input 'L'-Level Voltage	V_{IL}					0.8	V
Input 'H'-Level Voltage	V_{IH}		2.0				V
Input 'L'-Level Current	I_{IL}	$V_I = 0.8\text{V}$	-10		+10		μA
Input 'H'-Level Current	I_{IH}	$V_I = 2\text{V}$ $V_I = 5\text{V}$		6	10		μA
Current Dissipation	I_{CL}	STB=0.8V V_{CC}		0.55	1.0		mA
	I_{SL}	STB=0.8V V_S , Note 1			1		mA
	I_{CH}	STB=2.0V V_{CC}		25	33		mA
	I_{SH}	STB=2.0V V_S , Note 1			5	10	mA
Output Transistor Voltage	V_{CER}	$I_C = 10\text{mA}$	18				V
V_{S1} Saturation Voltage	V_{sat}	SB=0.8V, $I_O = 330\text{mA}$, Note 2		1.5	2.0		V
Clamp Voltage	V_F	$I_F = 330\text{mA}$ Upper		3			V
		$I_F = 330\text{mA}$ Lower		1.5			V
Delay Time	t_{PLH}			4			μs
	t_{PHL}			2			μs
TSD Operating Temperature	TSD			150			$^\circ\text{C}$
TSD Hysteresis	ΔT			25			$^\circ\text{C}$

Note) 1. Measure sum of currents at pins 4 and 13.

2. Measure sum of saturation voltages at upper and lower level.

Equivalent Circuit Block Diagram

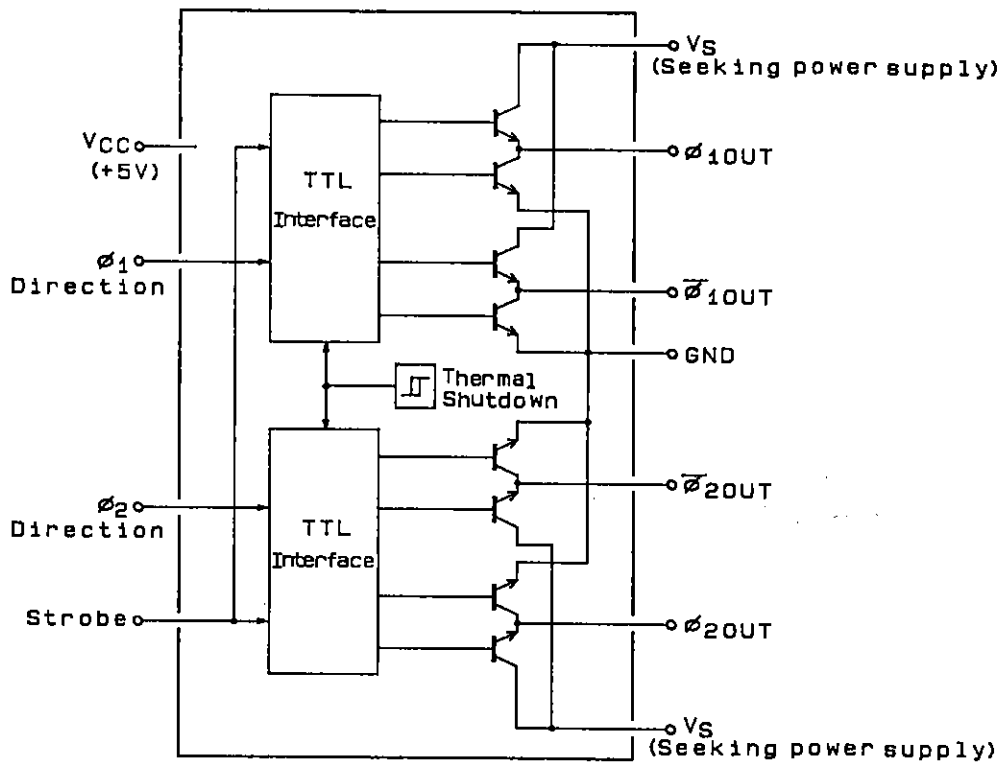

The ø1, ø2 direction inputs are used to make driver output selection and the power save input is used to select the driver source output from between 0V supply and 12V supply.

LB1657M

Pin Assignment

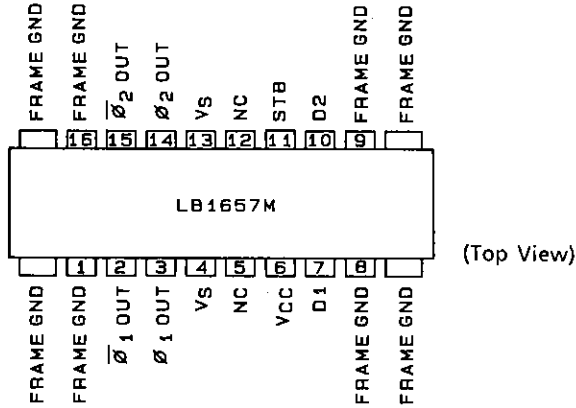

Specified board

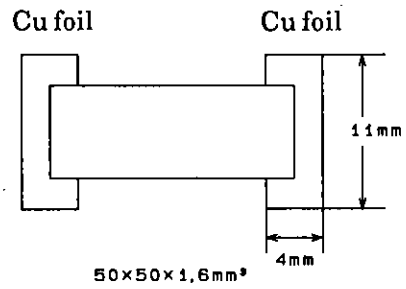

Sample Application Circuit

2-phase bipolar stepping motor driver

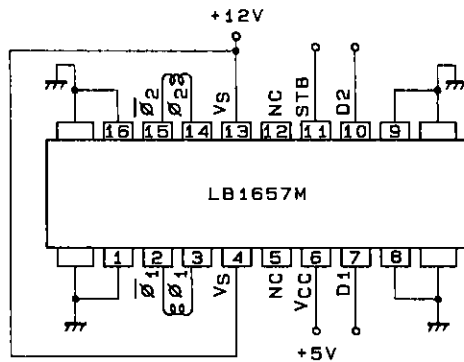

Note) Keep the Terminal to Short 4 and 13

Timing Chart

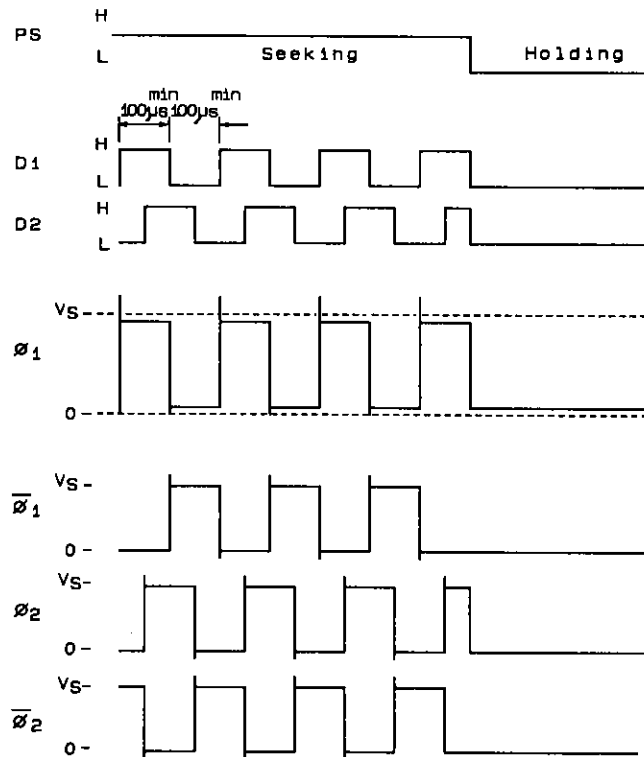

- No products described or contained herein are intended for use in surgical implants, life-support systems, aerospace equipment, nuclear power control systems, vehicles, disaster/crime-prevention equipment and the like, the failure of which may directly or indirectly cause injury, death or property loss.
- Anyone purchasing any products described or contained herein for an above-mentioned use shall:
 - ① Accept full responsibility and indemnify and defend SANYO ELECTRIC CO., LTD., its affiliates, subsidiaries and distributors and all their officers and employees, jointly and severally, against any and all claims and litigation and all damages, cost and expenses associated with such use;
 - ② Not impose any responsibility for any fault or negligence which may be cited in any such claim or litigation on SANYO ELECTRIC CO., LTD., its affiliates, subsidiaries and distributors or any of their officers and employees jointly or severally.
- Information (including circuit diagrams and circuit parameters) herein is for example only; it is not guaranteed for volume production. SANYO believes information herein is accurate and reliable, but no guarantees are made or implied regarding its use or any infringements of intellectual property rights or other rights of third parties.