

GENERAL PURPOSE DARLINGTON TRANSISTOR.

FEATURES

- High DC Current Gain : $h_{FE}=3000(\text{Min.})$ ($V_{CE}=-2V, I_C=-1A$)
- Complementary to KTD2424.

MAXIMUM RATINGS ($T_a=25^\circ\text{C}$)

CHARACTERISTIC	SYMBOL	RATING	UNIT
Collector-Base Voltage	V_{CBO}	-80	V
Collector-Emitter Voltage	V_{CEO}	-60	V
Emitter-Base Voltage	V_{EBO}	-10	V
Collector Current	I_C	-3	A
Base Current	I_B	-0.5	A
Collector Power Dissipation ($T_c=25^\circ\text{C}$)	P_C	25	W
Junction Temperature	T_j	150	$^\circ\text{C}$
Storage Temperature Range	T_{stg}	-55~150	$^\circ\text{C}$

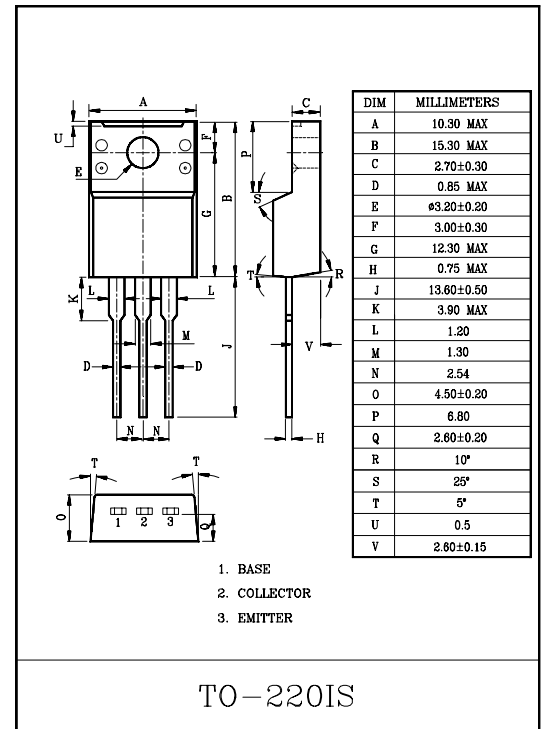

ELECTRICAL CHARACTERISTICS ($T_a=25^\circ\text{C}$)

CHARACTERISTIC	SYMBOL	TEST CONDITION	MIN.	TYP.	MAX.	UNIT	
Collector Cut-off Current	I_{CBO}	$V_{CB}=-80V, I_E=0$	-	-	-20	μA	
Emitter Cut-off Current	I_{EBO}	$V_{EB}=-10V, I_C=0$	-	-	-100	μA	
Collector-Emitter Breakdown Voltage	$V_{(BR)CEO}$	$I_C=-10mA, I_B=0$	-60	-	-	V	
DC Current Gain	$h_{FE}(1)$	$V_{CE}=-2V, I_C=-1A$	3000	-	-		
	$h_{FE}(2)$	$V_{CE}=-2V, I_C=-3A$	1000	-	-		
Saturation Voltage	Collector-Emitter	$V_{CE(sat)}$	$I_C=-3A, I_B=-30mA$	-	-	-1.5	V
	Base-Emitter	$V_{BE(sat)}$	$I_C=-3A, I_B=-30mA$	-	-	-2.8	