

JT9673-AS

LCD Display Stopwatch LSI

This product is a single-chip CMOS LSI for stopwatches capable of directly driving a 7-digit LCD with four signs.

Applications

- Stopwatches

Features

- 32.768 kHz crystal oscillator
- Displays hour, minute, second, and hundredths of seconds
- Four-sign, 7-digit display, 1/3-duty LCD drive
- 5 display modes (RESET, RUN, STOP, LAP, LAP STOP) and optional display modes (NORMAL LAP, SECTION LAP) are selectable by bonding option.
- Counting by 9 hours, 59 minutes, 59 seconds, 99 hundredths of second (units: 1/100 second)
- Power supply: 1.55 V-single power supply
- Built-in voltage doubler circuit
- Low current consumption ($I_{sup} = 3.0 \mu A$ max)

Block Diagram

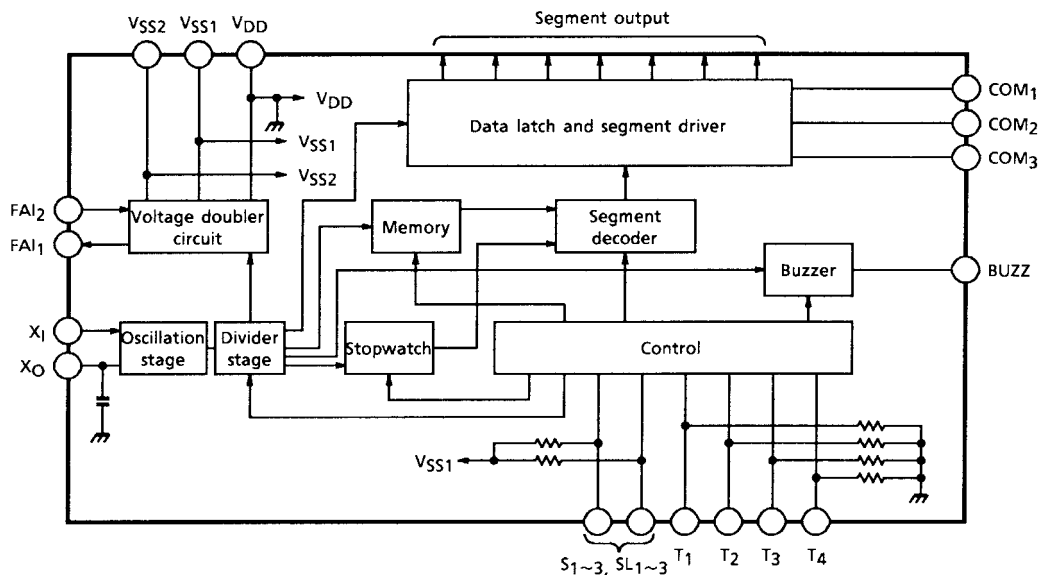

Pin Descriptions (44 pins)

Pin Name	Symbol	No. of Pins
Power Supply Pins	V _{DD} (2), V _{SS1} , V _{SS2}	4
Oscillator Pins	X _I , X _O	2
Input Pins	S _{1~3} , SL _{1~3}	6
Output Pin	BUZZ	1
Display Pins	COM _{1~3} , SEG (22)	25
Test Pins	T _{1~4}	4
Voltage Doubler Pins	FAI ₁ , FAI ₂	2

Pad Layout

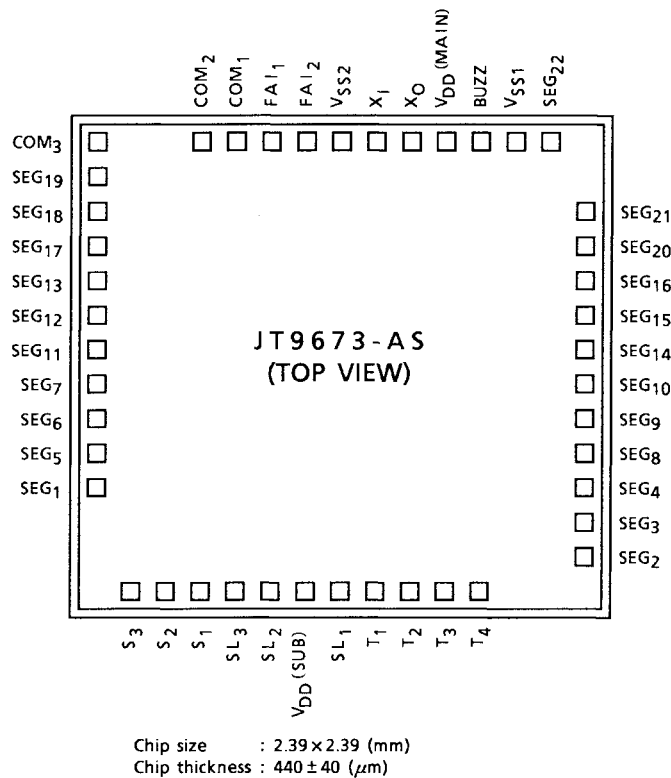

Note 1: Be sure to connect the V_{DD} (MAIN).

Pad Location Table

(μm)

Pin Name	X Point	Y Point	Pin Name	X Point	Y Point
SEG ₁	-1067	-618	SEG ₂₁	1067	618
SEG ₅	-1067	-455	SEG ₂₀	1067	455
SEG ₆	-1067	-292	SEG ₁₆	1067	292
SEG ₇	-1067	-129	SEG ₁₅	1067	130
SEG ₁₁	-1067	33	SEG ₁₄	1067	-33
SEG ₁₂	-1067	196	SEG ₁₀	1067	-196
SEG ₁₃	-1067	359	SEG ₉	1067	-359
SEG ₁₇	-1067	522	SEG ₈	1067	-522
SEG ₁₈	-1067	684	SEG ₄	1067	-684
SEG ₁₉	-1067	847	SEG ₃	1067	-847
COM ₃	-1067	1010	SEG ₂	1067	-1010
COM ₂	-618	1067	T ₄	618	-1067
COM ₁	-455	1067	T ₃	455	-1067
FAI ₁	-292	1067	T ₂	292	-1067
FAI ₂	-129	1067	T ₁	130	-1067
V _{SS2}	33	1067	SL ₁	-33	-1067
X _I	196	1067	V _{DD} (SUB)	-196	-1067
X _O	359	1067	SL ₂	-359	-1067
V _{DD} (MAIN)	522	1067	SL ₃	-522	-1067
BUZZ	684	1067	S ₁	-684	-1067
V _{SS1}	847	1067	S ₂	-847	-1067
SEG ₂₂	1010	1067	S ₃	-1010	-1067

Function Specifications

1. LCD Segment Pattern

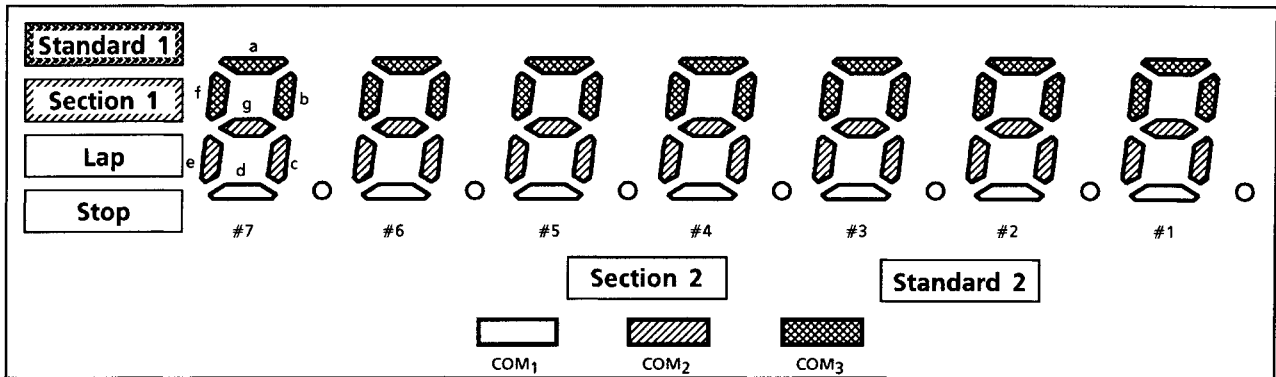

	COM ₁	COM ₂	COM ₃		COM ₁	COM ₂	COM ₃
SEG ₁	Lap	Section 1	Standard 1	SEG ₁₂	4d	4g	4a
SEG ₂	Stop	7e	7f	SEG ₁₃	4p	4c	4b
SEG ₃	7d	7g	7a	SEG ₁₄	—	3e	3f
SEG ₄	7p	7c	7b	SEG ₁₅	3d	3g	3a
SEG ₅	—	6e	6f	SEG ₁₆	3p	3c	3b
SEG ₆	6d	6g	6a	SEG ₁₇	Standard 2	2e	2f
SEG ₇	6p	6c	6b	SEG ₁₈	2d	2g	2a
SEG ₈	—	5e	5f	SEG ₁₉	2p	2c	2b
SEG ₉	5d	5g	5a	SEG ₂₀	—	1e	1f
SEG ₁₀	5p	5c	5b	SEG ₂₁	1d	1g	1a
SEG ₁₁	Section 2	4e	4f	SEG ₂₂	1p	1c	1b

2. LCD Drive Waveform

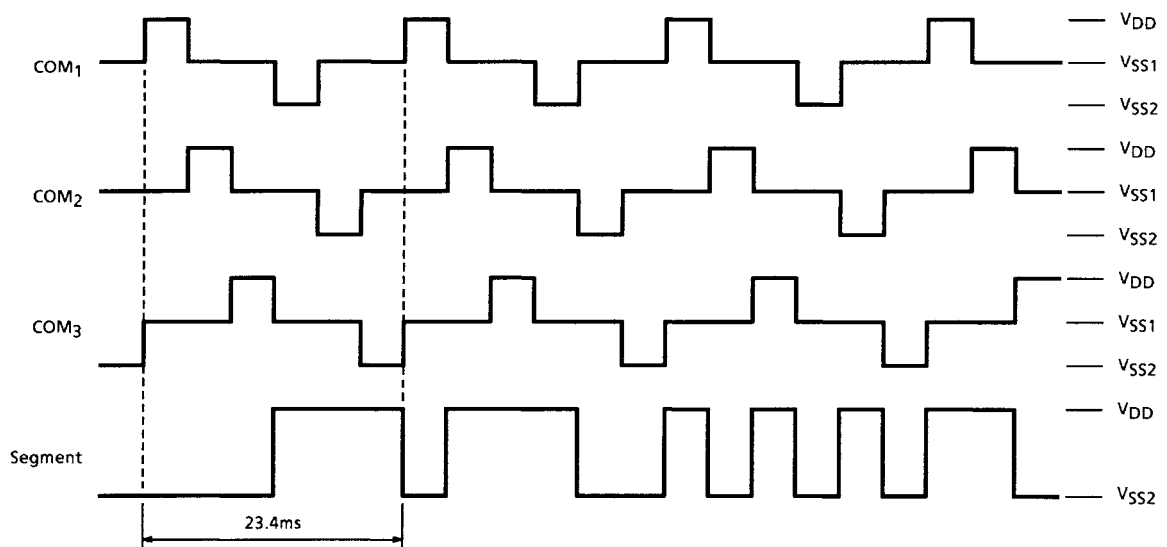

3. Display Modes

Ⓐ 1/100 second display

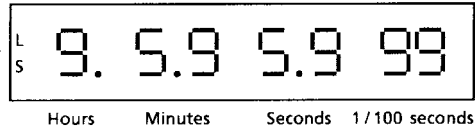

Ⓑ 1/10 second display

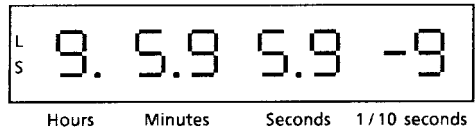

Selected by SL1. (See 7. Type Selection Function below.)

4. Display Sequence

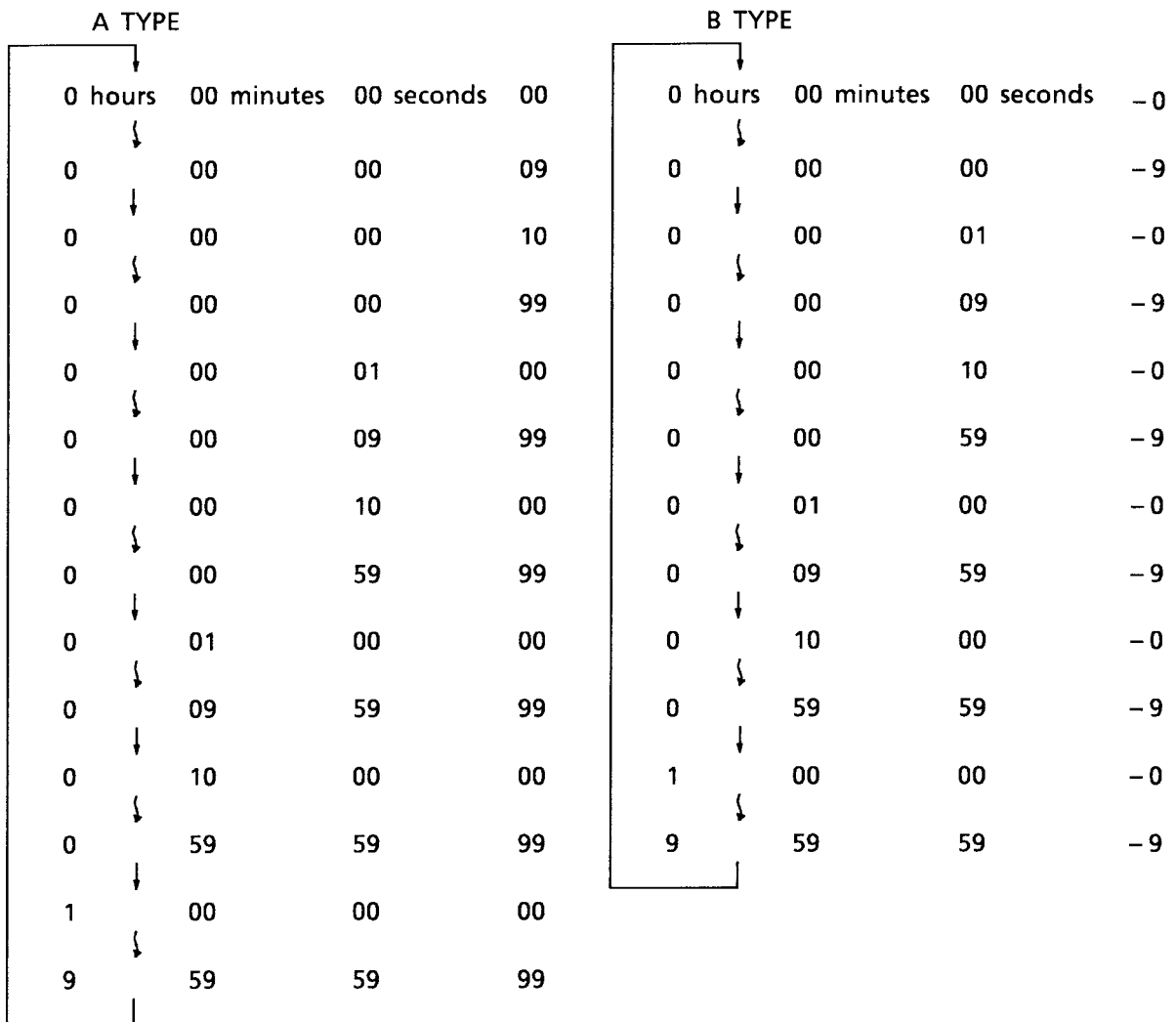

The display returns from 9 hours, 59 minutes, 59 seconds, 99 1/100 seconds, to 0 hours, 00 minutes, 00 seconds 00 and counting continues.

5. Display Example

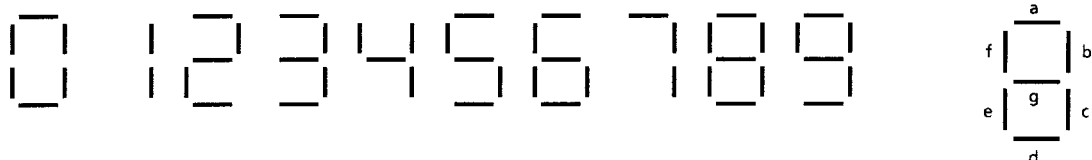

6. Input Setting

S1, S2, S3: Normally all pulled down to the VSS1 level by IC internal pull-down resistance. S1, S2, and S3 perform their specified functions when connected to the VDD by an external switch.

SL1, SL2, SL3: Normally, all pulled down to the VSS1 level by IC internal pull-down resistance.

Setting the level of the pins externally allows functions to be selected

T1, T2, T3, T4: Normally, all pulled up to the VDD level by IC internal pull-up resistance. Used for IC testing.

7. Type Selection Function

SL ₁	SL ₂	SL ₃	Type
0	—	—	A Type (1/100 seconds display)
1	—	—	B Type (1/10 seconds display)
—	0	0	C Type
—	1	0	D Type
—	0	1	E Type
—	1	1	F Type

See 8. Mode Sequence.

Note 2: '0' indicates input is OPEN or connect to VSS1.

'—' indicates don't care.

8. Mode Sequence

(1) C type

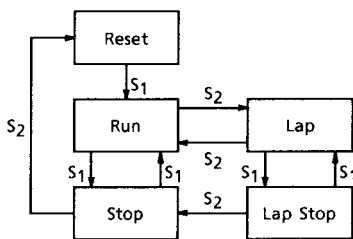

Starts functioning on the rising edge of S1 and S2

(2) D type

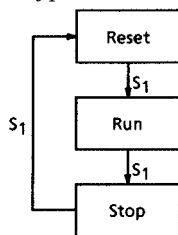

(3) E type

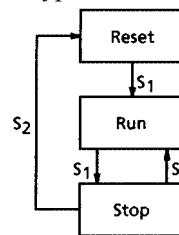

(4) F type

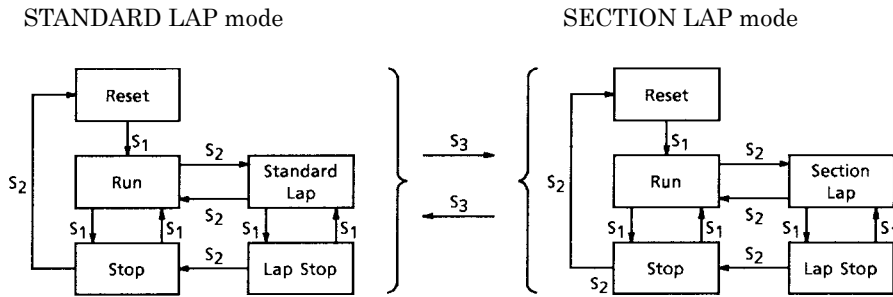

- S₃ toggles between STANDARD LAP mode and SECTION LAP mode.
- In SECTION LAP mode, when switched from RUN to LAP, the counter is immediately reset to '0'.
- When switched from SECTION LAP mode to NORMAL LAP mode by pressing S₃, the counter is not reset to '0'.

9. Display Column Table

Display Column Mode	Digit Segment							Dot Segment					Sign						
	7	6	5	4	3	2	1	7P	6P	5P	4P	3P	2P	1P	Lap	Stop	Standard	Section	
Reset	□	□	□	□	□	(—)	□ (□)	•	(1)		△						(1)	△	
Run	Hour	10 min-utes	1 min-ute	10 sec-onds	1 sec-ond	1/10 second	1/100 second (1/10 second)	•	(1)		△						(1)	△	
Stop	Hour	10 min-utes	1 min-ute	10 sec-onds	1 sec-ond			•	(1)		△						•	(1)	△
Lap	Hour	10 min-utes	1 min-ute	10 sec-onds	1 sec-ond			•	(1)		△					●		(1)	△
Lap Stop	Hour	10 min-utes	1 min-ute	10 sec-onds	1 sec-ond			•	(1)		△					•	•	(1)	△

Note 3: When 1/10 s type is selected, only the first and second column displays are different. The display is as in the parentheses ().

Note 4: '•' indicates 'lit'. (7P always lit)

Note 5: '●' indicates flashing at 1 Hz.

Note 6: In the F type only, '(1)' flashes at 1 Hz when STANDARD LAP mode is selected.

Note 7: In the F type only, '△' flashes at 1 Hz when SECTION LAP mode is selected.

Note 8: 1P, 2P, 3P, and 5P do not light.

10. Chattering Prevention Function

A chattering prevention circuit is provided for the S₁, S₂, and S₃ inputs. The input waveform shown below does not cause malfunction.

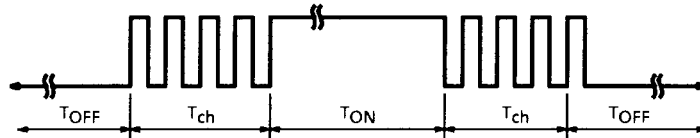

$T_{ch} < 31.25 \text{ ms}$

$T_{ON, OFF} \geq 31.25 \text{ ms}$

11. Buzzer Drive Function

Pressing S₁ or S₂ turns the buzzer drive circuit ON for around 30~60 ms. The drive frequency is 4 kHz.

12. Autoclear Circuit

An autoclear circuit is incorporated for when the power supply is switched ON, at which time the counter reads “0” and RESET mode is selected. (to operate the autoclear circuit more dependably, externally attach a capacitor between T₂ and VSS₁.)

13. Input Circuit Setting Error

The S₁, S₂ switch input circuit operates on the first rising edge of the input. The error for one switching is a maximum of 1/100 second.

14. Test Functions

T ₁	T ₂	T ₃	T ₄	S ₁	S ₂	Function
1	1	1	1	0	0	Normal
1	0	—	—	—	—	All clear
0	ϕT_2	—	—	—	—	Acceleration from the 256 Hz stage using ϕT_2
—	—	0	0	1	0	Output 100 Hz to BUZZ pin
—	—	0	0	0	1	+1 h by S ₂
—	—	1	0	1	—	+10 mins by S ₁
—	—	1	0	—	1	+1 min by S ₂
—	—	0	1	1	—	+10 s by S ₁
—	—	0	1	—	1	+1 s by S ₂
—	—	0	0	1	1	LCD all lit, BUZZ output (H level)

Note 9: When T₃ = 0 or T₄ = 0, the normal functions of S₁ and S₂ are disabled.

Note 10: An ALL CLEAR sets to RESET mode (0 hours, 00 minutes, 00 seconds, 00 1/100 seconds).

15. All Clear Function

When power is applied or when the supply of power is interrupted (e.g. if the battery is changed), the internal state of the IC may become unstable, even though it appears to be operating normally. For this reason it is vital to verify that the crystal oscillation circuit is oscillating normally and stably (at 32 kHz) and then to use the system reset pin to initialize the IC (i.e. clear it) before use.

Note that a clear operation using the built-in power-on clear circuit should not be used in this case.

Maximum Ratings (if no temperature stipulations, Ta = 25°C)

Characteristics	Symbol	Rating	Unit
Power supply voltage (1)	V _{SS1} -V _{DD}	-3.0~0.2	V
Power supply voltage (2)	V _{SS2} -V _{DD}	-4.5~0.2	V
Input voltage (1)	V _{IN1}	V _{SS1} - 0.2~V _{DD} + 0.2	V
Input voltage (2)	V _{IN2}	V _{SS2} - 0.2~V _{DD} + 0.2	V
Output voltage (1)	V _{OUT1}	V _{SS1} - 0.2~V _{DD} + 0.2	V
Output voltage (2)	V _{OUT2}	V _{SS2} - 0.2~V _{DD} + 0.2	V
Operating temperature	T _{opr}	-10~60	°C
Storage temperature	T _{stg}	-40~125	°C

Electrical Characteristics

(unless otherwise stated, V_{DD} = 0.00 V, V_{SS1} = -1.55 V, V_{SS2} = -3.00 V, C_G = 20 pF, C_D = built-in (10 pF), C_{IMAX} = 21 kΩ, F_o = 32768 Hz)

Characteristics	Symbol	Test Circuit	Test Condition	Min	Typ.	Max	Unit
Operating voltage	V _{SS1} -V _{DD}	3	—	1.25	1.55	1.80	V
Operating current consumption	I _{sup}	2	No LCD load	—	—	3.0	μA
Oscillation start voltage	V _{STA}	3	t _{STA} 10 s	—	—	1.40	V
Output current (1)	I _{OH1}	4	V _{OH1} = -0.2 V	—	—	-0.5	μA
Segment	I _{OL1}	4	V _{OL1} = -2.8 V	0.5	—	—	
Output current (2)	I _{OH2}	4	V _{OH2} = -0.2 V	—	—	-4.0	μA
Common	I _{OL2}	4	V _{OL2} = -2.8 V	4.0	—	—	
Output current (3)	I _{OH3}	4	V _{SS1} = -1.25 V V _{OH3} = -0.5 V	—	—	-100	μA
Buzzer	I _{OL3}	4	V _{SS2} = -2.8 V V _{OL3} = -0.75 V	100	—	—	
Input current (1)	I _{IH1}	4	V _{IH1} = 0 V	1.55	—	20.0	μA
S ₃ , SL ₁ , SL ₂ , SL ₃	I _{IL1}	4	V _{IL1} = -1.55 V	-0.1	—	—	
Input current (2)	I _{IH2}	4	V _{IH2} = 0 V	—	—	0.1	μA
T ₁ , T ₃ , T ₄	I _{IL2}	4	V _{IL2} = -1.55 V	—	-50	—	
Input current (3)	I _{IH3}	4	V _{IH3} = 0 V	—	—	0.1	μA
T ₂	I _{IL3}	4	V _{IL3} = -1.55 V	-15.5	—	—	
Input current (4)	I _{IH4}	4	V _{IH4} = 0 V	15.5	—	150	μA
S ₁ , S ₂	I _{IL4}	4	V _{IL4} = -1.55 V	-0.1	—	—	
Voltage doubler output	V _{UCO}	2	C ₁ = C ₂ = 0.1 μF, R _L = 3 MΩ	3.0	—	—	V

Test Circuit

1. Oscillation Circuit

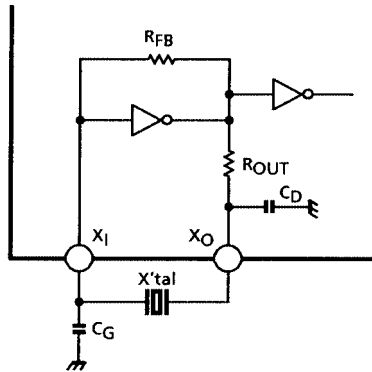

X'tal

$R_S = 21 \text{ k}\Omega$

$F_0 = 32.768 \text{ kHz}$

$C_G = 20 \text{ pF}$

$C_D = 10 \text{ pF}$ built in

2. Measuring I_{sup} and V_{UCO}

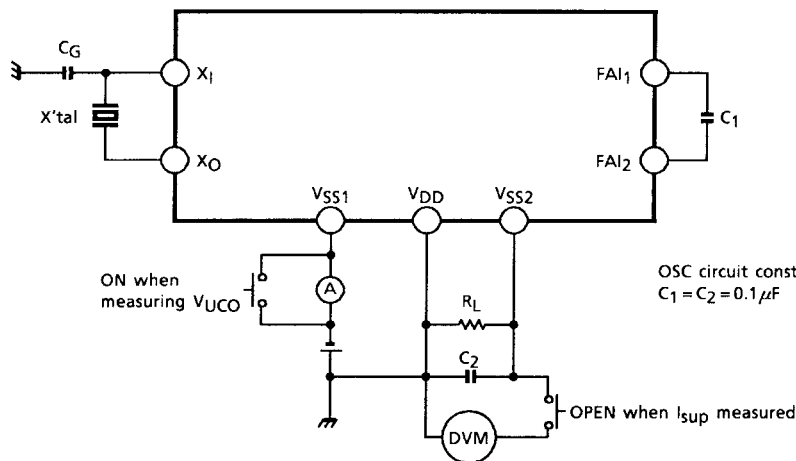

OSC circuit constants same as test circuit 1.
 $C_1 = C_2 = 0.1 \mu\text{F}$

3.

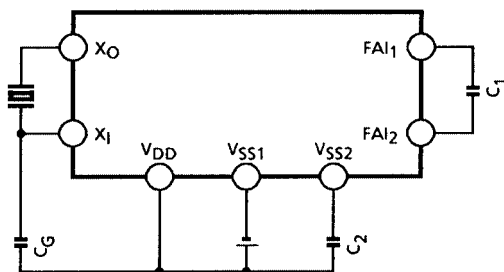

4.

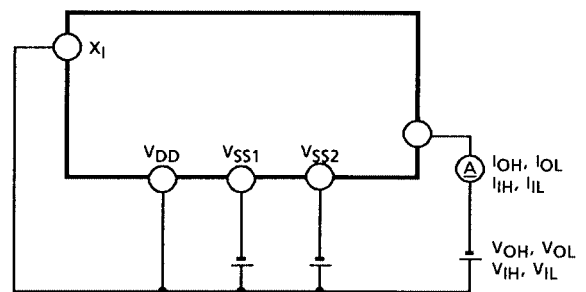

When measuring SL_1, SL_2, SL_3 , set T_2 to $VSS1$.

Application Circuit Example

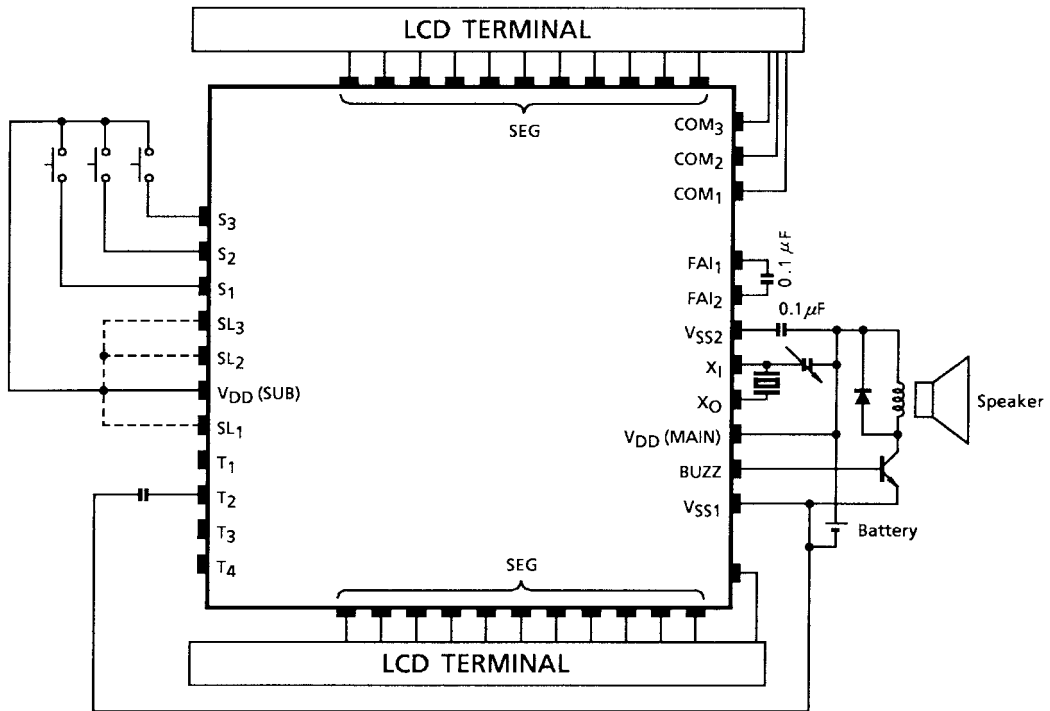

Note 11: Be sure to connect the V_{DD} (MAIN).

RESTRICTIONS ON PRODUCT USE

000707EBA

- TOSHIBA is continually working to improve the quality and reliability of its products. Nevertheless, semiconductor devices in general can malfunction or fail due to their inherent electrical sensitivity and vulnerability to physical stress. It is the responsibility of the buyer, when utilizing TOSHIBA products, to comply with the standards of safety in making a safe design for the entire system, and to avoid situations in which a malfunction or failure of such TOSHIBA products could cause loss of human life, bodily injury or damage to property.
In developing your designs, please ensure that TOSHIBA products are used within specified operating ranges as set forth in the most recent TOSHIBA products specifications. Also, please keep in mind the precautions and conditions set forth in the "Handling Guide for Semiconductor Devices," or "TOSHIBA Semiconductor Reliability Handbook" etc..
- The TOSHIBA products listed in this document are intended for usage in general electronics applications (computer, personal equipment, office equipment, measuring equipment, industrial robotics, domestic appliances, etc.). These TOSHIBA products are neither intended nor warranted for usage in equipment that requires extraordinarily high quality and/or reliability or a malfunction or failure of which may cause loss of human life or bodily injury ("Unintended Usage"). Unintended Usage include atomic energy control instruments, airplane or spaceship instruments, transportation instruments, traffic signal instruments, combustion control instruments, medical instruments, all types of safety devices, etc.. Unintended Usage of TOSHIBA products listed in this document shall be made at the customer's own risk.
- The products described in this document are subject to the foreign exchange and foreign trade laws.
- The information contained herein is presented only as a guide for the applications of our products. No responsibility is assumed by TOSHIBA CORPORATION for any infringements of intellectual property or other rights of the third parties which may result from its use. No license is granted by implication or otherwise under any intellectual property or other rights of TOSHIBA CORPORATION or others.
- The information contained herein is subject to change without notice.