

14.2 mm (0.56 inch) General Purpose Blue Seven Segment Displays

Technical Data

HDSP-50xB Series

Features

- **Industry Standard Size**
- **Industry Standard Pin-Out**
15.24 mm (0.6 in.) DIP Leads on 2.54 mm (0.1 in.) Centers
- **Blue Color**
- **Mitered Font**
Mitered Corners on Segments
- **Gray Face Paint**
Gray Package Gives Optimum Contrast
- **± 50° Viewing Angle**
- **Design Flexibility**
Common Anode or Common Cathode
- **Categorized for Luminous Intensity**

Applications

- **Suitable for Indoor Use**
- **Not Recommended for Industrial Applications, i.e. Operating Temperatures**

Devices

Blue HDSP-	Description
501B	Common Anode Right Hand Decimal
503B	Common Cathode Right Hand Decimal

Note:

1. For details, please contact your local Agilent components sales office or an authorized distributor.

Requirements Exceeding 80°C or Below -20°C^[1]

- **Extreme Temperature Cycling Not Recommended^[1]**

Description

These 14.2 mm (0.56 inch) blue displays use industry standard size and pin-out. The devices are available as either common anode or common cathode. The HDSP-50xB series are suitable for indoor use.



Part Numbering System

5082 - X XX X - X X XX XX

HDSP - X XX X - X X XX XX

Mechanical Options^[1]

00: No Mechanical Option

Color Bin Options^[1,2]

0: No Color Bin Limitation

Minimum Intensity Bin^[1,2]

0: No Maximum Intensity Bin Limitation

Minimum Intensity Bin^[1,2]

0: No Minimum Intensity Bin Limitation

Device Configuration/Color^[1]

B: Blue

Device Specification Configuration^[1]

Refer to Respective Datasheet

Package^[1]

Refer to Respective Datasheet

Notes:

1. For codes not listed in the figure above, please refer to the respective datasheet or contact your nearest Agilent representative for details.
2. Bin options refer to shippable bins for a part-number. Color and Intensity Bins are typically restricted to 1 bin per tube (exceptions may apply). Please refer to respective datasheet for specific bin limit information.

Package Dimensions

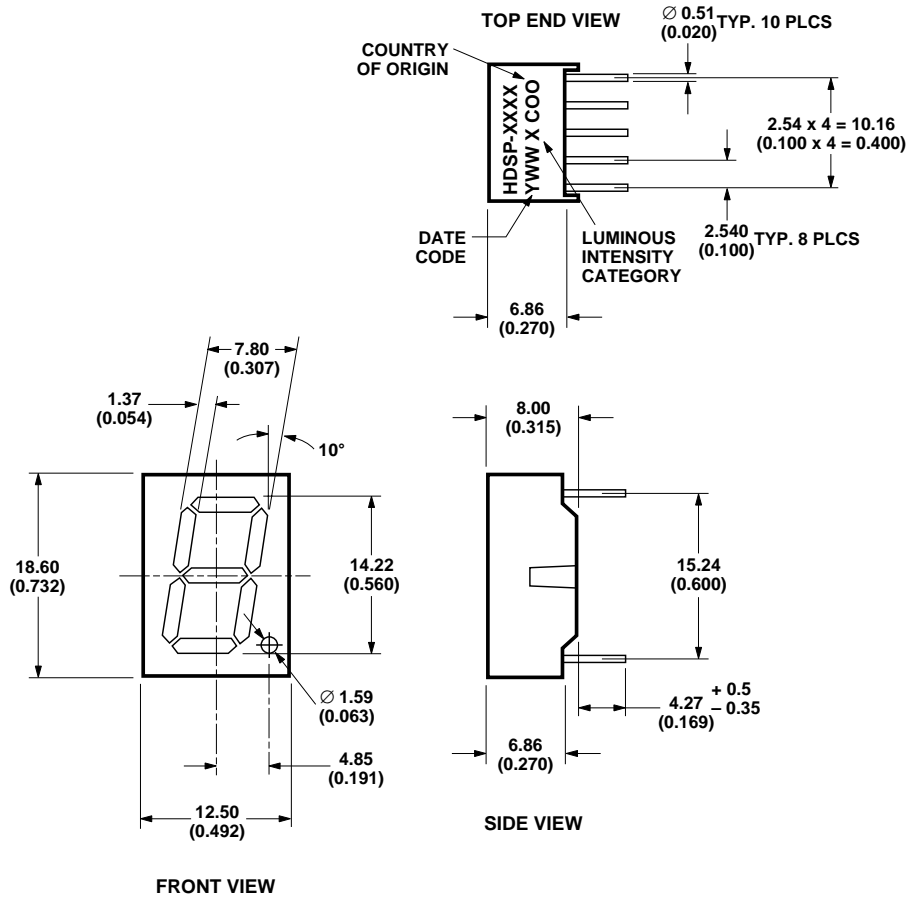

- NOTES:**
1. ALL DIMENSIONS ARE IN MILLIMETERS (INCHES).
 2. UNLESS OTHERWISE STATED, TOLERANCES ARE ± 0.25 mm.

Internal Circuit Diagram

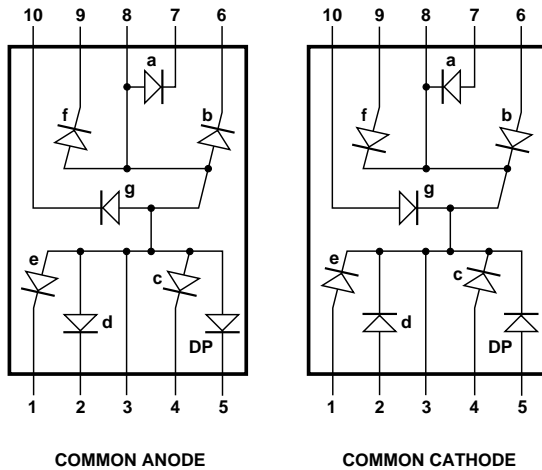

HDSP-501B		HDSP-503B	
COMMON ANODE		COMMON CATHODE	
PIN	FUNCTION	PIN	FUNCTION
1	CATHODE e	1	ANODE e
2	CATHODE d	2	ANODE d
3	COMMON ANODE	3	COMMON CATHODE
4	CATHODE c	4	ANODE c
5	CATHODE DP	5	ANODE DP
6	CATHODE b	6	ANODE b
7	CATHODE a	7	ANODE a
8	COMMON ANODE	8	COMMON CATHODE
9	CATHODE f	9	ANODE f
10	CATHODE g	10	ANODE g

Absolute Maximum Ratings at $T_A=25^\circ\text{C}$

Parameter	Symbol	HDSP-501B HDSP-503B	Units
Power Dissipated per Segment or DP	P_D	135	mW
Peak Forward Current per Segment or DP (1/10 Duty Cycle, 0.1 ms Pulse Width)	I_{PEAK}	70	mA
DC Forward Current per Segment or DP ^[1]	I_F	30 ^[1]	mA
Reverse Voltage per Segment or DP	V_R	5	V
Operating Temperature	T_O	-20 to +80	$^\circ\text{C}$
Storage Temperature	T_S	-30 to +85	$^\circ\text{C}$
Wave Soldering Conditions (1.6 mm [0.063 in.] below Body)	Temperature	250	$^\circ\text{C}$
	Time	3	s

Note:

- Derate above 25°C at 0.33 mA/ $^\circ\text{C}$.

Optical/Electrical Characteristics at $T_A=25^\circ\text{C}$

Devices HDSP-	Parameter	Symbol	Min.	Typ.	Max.	Units	Test Conditions
501B 503B	Luminous Intensity/Segment (Segment Average) ^[1,2]	I_V	2.02	3.40		mcd	$I_F = 10\text{ mA}$
	Forward Voltage/Segment or DP	V_F		3.80	4.50	V	$I_F = 20\text{ mA}$
	Peak Wavelength	λ_{PEAK}		428		nm	
	Dominant Wavelength ^[3]	λ_d		466		nm	
	Reverse Current/Segment or DP ^[4]	I_R				100	μA

Notes:

- Case temperature of the device immediately prior to the intensity measurement is 25°C .
- The digits are categorized for luminous intensity. The intensity category is designated by a letter on the side of the package.
- The dominant wavelength, λ_d , is derived from the CIE chromaticity diagram and represents the single wavelength which defines the color of the device.
- Typical specification for reference only. Do not exceed absolute maximum ratings.

Intensity Bin Limits^[1] (μcd at 10 mA)

Bin Name	Min. ^[2]	Max. ^[2]
H	2020	2630
I	2630	3420
J	3420	4200
K	4200	5040

Notes:

- Bin categories are established for classification of products. Products may not be available in all bin categories.
- Tolerance for each bin limit is $\pm 10\%$.

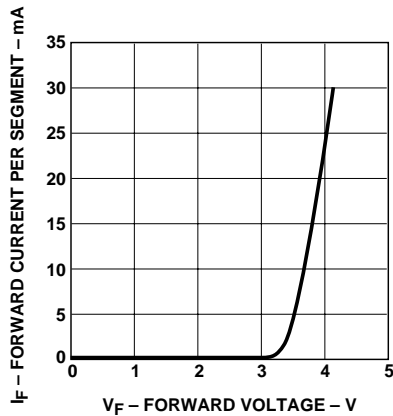

Figure 1. Forward Current vs. Forward Voltage.

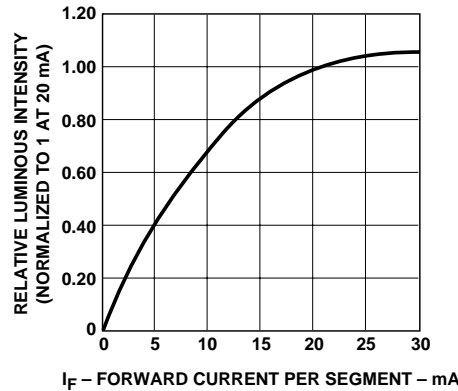

Figure 2. Relative Luminous Intensity vs. DC Forward Current.

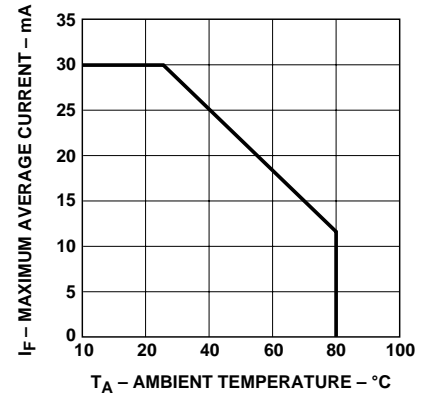

Figure 3. Maximum Allowable Average Current per Dot vs. Ambient Temperature.

Contrast Enhancement

For information on contrast enhancement, please see Application Note 1015.

Soldering/Cleaning

Cleaning agents from the ketone family (acetone, methyl ethyl ketone, etc.) and from the chlorinated hydrocarbon family (methylene chloride, trichloroethylene, carbon tetrachloride, etc.) are not recommended for cleaning LED parts. All of these various solvents attack or dissolve the encapsulating epoxies used to form the package of plastic LED parts.

For information on soldering LEDs please refer to Application Note 1027.

Device Reliability

For reliability information, please see the reliability data sheet 14.2 mm (0.56 inch) General Purpose Blue Seven Segment Display.

www.agilent.com/semiconductors

For product information and a complete list of distributors, please go to our web site.

For technical assistance call:

Americas/Canada: +1 (800) 235-0312 or (916) 788-6763

Europe: +49 (0) 6441 92460

China: 10800 650 0017

Hong Kong: (+65) 6756 2394

India, Australia, New Zealand: (+65) 6755 1939

Japan: (+81 3) 3335-8152 (Domestic/International), or 0120-61-1280 (Domestic Only)

Korea: (+65) 6755 1989

Singapore, Malaysia, Vietnam, Thailand, Philippines, Indonesia: (+65) 6755 2044

Taiwan: (+65) 6755 1843

Data subject to change.

Copyright © 2004 Agilent Technologies, Inc.

Obsoletes 5988-0378EN

July 17, 2004
5988-8000EN