

HA16178P/FP

Power Factor Correction Controller IC

REJ03D0903-0100

Rev.1.00

Jun 12, 2007

Description

The HA16178P/FP is a power-factor correction (PFC) controller IC.

This IC adopts continuous conduction mode as PFC operation.

Various functions such as over voltage detection, over current detection, soft start, feedback-loop disconnection detection, are incorporated in a single chip. This eliminates a significant amount of external circuitry.

PFC operation can be turned on and off by an external control signal. By using this function, PFC operation can be disabled at low input voltage, allowing remote control from the secondary side.

A soft-start control pin provides for the easy adjustment of soft-start operation, and can be used to prevent overshooting of the output voltage.

Features

- Maximum ratings
 - Power-supply voltage V_{cc} : 24 V
 - Operating junction temperature T_{jopr} : -40 to 125°C
- Electrical characteristics
 - VREF output voltage V_{REF} : 5.0 V \pm 3%
 - UVLO operation start voltage V_H : 10.5 \pm 0.7 V
 - UVLO operation stop voltage V_L : 9.0 \pm 0.5 V
 - PFC output maximum ON duty $D_{max-out}$: 95% (typ.)
- Functions
 - Continuous conduction mode
 - Over voltage detection
 - Over current detection
 - Soft start
 - Feedback loop disconnection detection
 - PFC function on/off control
 - Package lineup: SOP-16 and DILP-16

Pin Arrangement

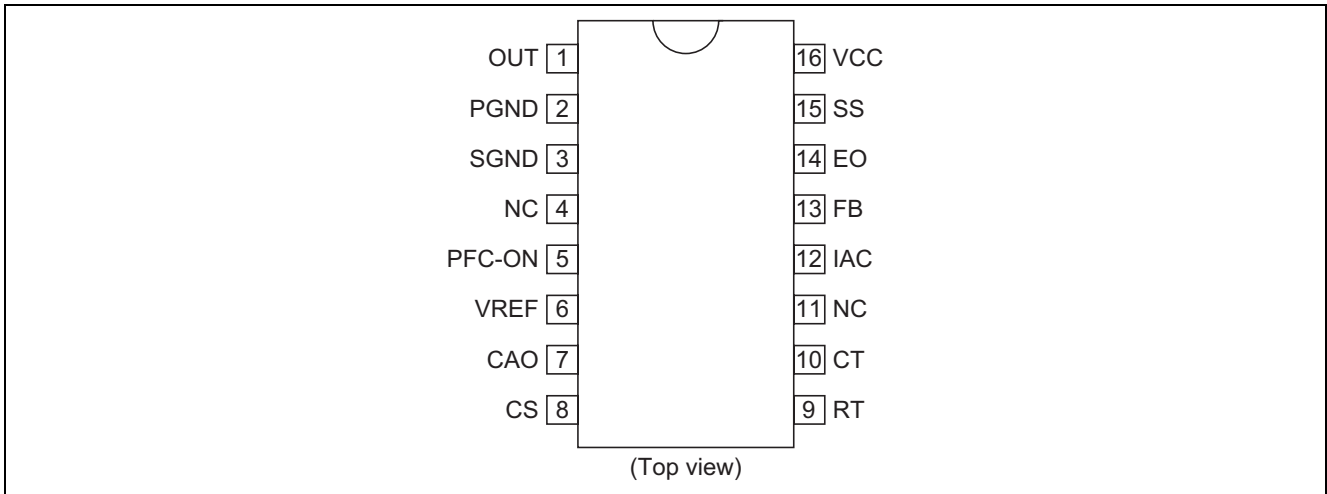

Pin Description

Pin No.	Pin Name	I/O	Function
1	OUT	Output	Power MOS FET gate driver output
2	PGND	—	Ground
3	SGND	—	Ground
4	NC	—	No connection
5	PFC-ON	Input	PFC function on/off signal input
6	VREF	Output	Reference voltage output
7	CAO	Output	Current control error amplifier output
8	CS	Input/Output	Current sense signal input
9	RT	Input/Output	Timing resistor for operational frequency adjust
10	CT	Output	Timing capacitor for operational frequency adjust
11	NC	—	No connection
12	IAC	Input	Multiplier reference current input
13	FB	Input	Voltage control error amplifier input
14	EO	Output	Voltage control error amplifier output
15	SS	Output	Timing capacitor for soft start time adjust
16	VCC	Input	Power supply voltage input

Block Diagram

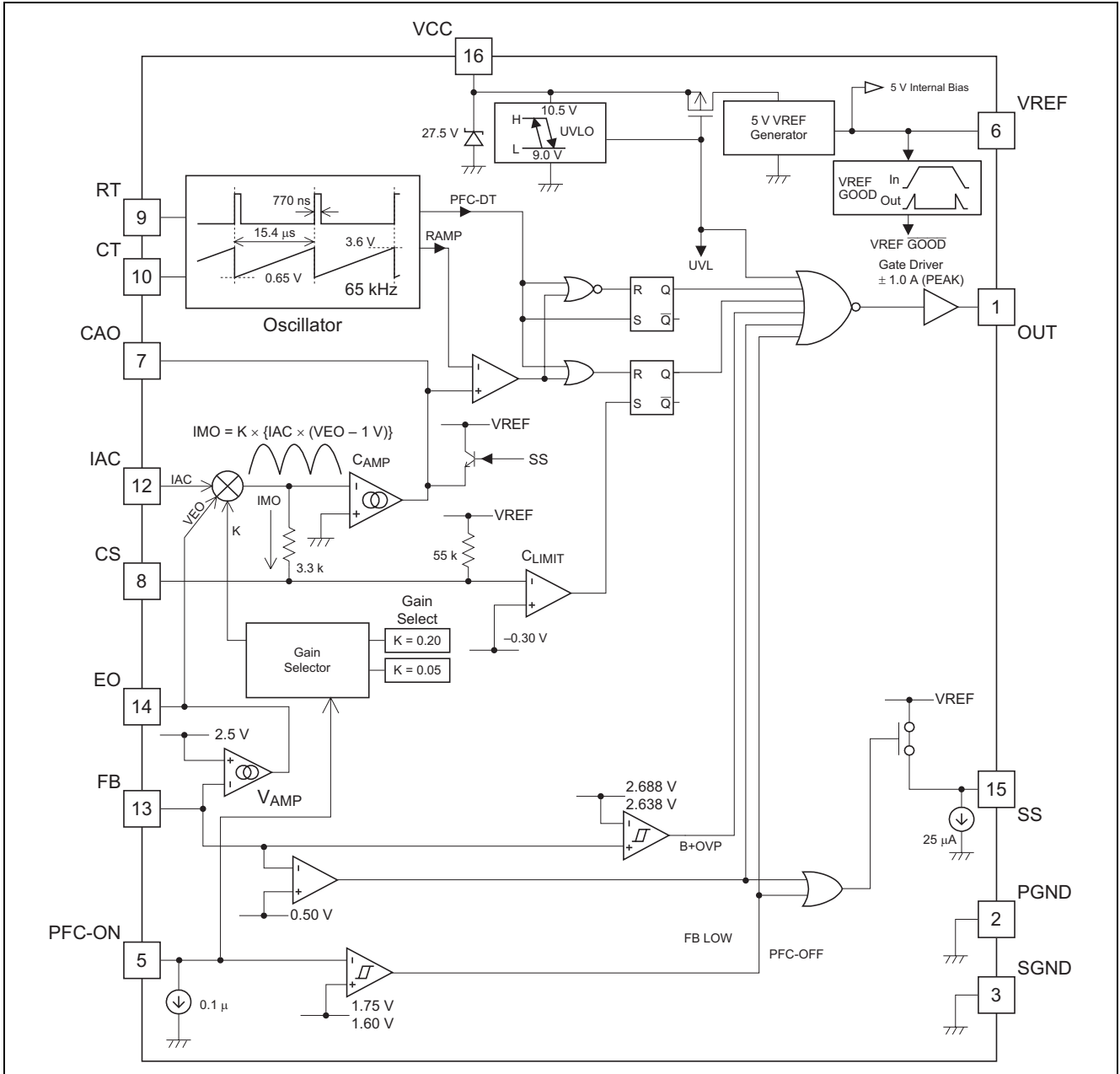

Absolute Maximum Ratings

(Ta = 25°C)

Item	Symbol	Ratings	Unit	Note
Supply voltage	VCC	24	V	
OUT peak current	Ipk-out	±1.0	A	3
OUT DC current	I _{dc-out}	±0.1	A	
Terminal voltage	Vi-group1	-0.3 to V _{cc}	V	4
	Vi-group2	-0.3 to V _{ref}	V	5
CAO voltage	V _{cao}	-0.3 to V _{caoh}	V	
EO voltage	V _{eo}	-0.3 to V _{eoh}	V	
PFC-ON voltage	V _{pfc-on}	-0.3 to +6.5	V	
PFC-ON clamp current	I _{pfc-on-clamp}	300	μA	
RT current	I _{rt}	-200	μA	
CT current	I _{ct}	±800	μA	
IAC current	I _{iac}	1	mA	
CS voltage	V _{i-cs}	-1.5 to 0.3	V	
VREF current	I _{o-ref}	-5	mA	
Power dissipation	P _t	1	W	6, 7
Operating junction temperature	T _{j-opr}	-40 to 125	°C	
Storage temperature	T _{stg}	-55 to 150	°C	

Notes: 1. Rated voltages are with reference to the GND pin.

2. For rated currents, inflow to the IC is indicated by (+), and outflow by (-).

3. The transient current when driving a capacitive load.

4. This is the rated voltage for the following pins:

OUT

5. This is the rated voltage for the following pins:

VREF, FB, IAC, SS, RT, CT

6. HA16178P (DILP) type: $\theta_{ja} = 120^{\circ}\text{C/W}$

7. HA16178FP (SOP) type: $\theta_{ja} = 120^{\circ}\text{C/W}$

This is value mounted on glass epoxy board of 10% wiring density and 40 mm × 40 mm × 1.6 mm.

Electrical Characteristics

(Ta = 25°C, VCC = 12 V, RT = 27 kΩ, CT = 1000 pF)

	Item	Symbol	Min	Typ	Max	Unit	Test Conditions
Supply	Start threshold	VH	9.8	10.5	11.2	V	
	Shutdown threshold	VL	8.5	9.0	9.5	V	
	UVLO hysteresis	dVUVL	1.0	1.5	2.0	V	
	Start-up current	Is	140	200	260	μA	VCC = 9.5 V
	Is temperature stability	dIs/dTa	—	-0.3	—	%/°C	* ¹
	Operating current	Icc	3.45	4.5	6.45	mA	IAC = 0 A, CL = 0 F
VREF	Output voltage	Vref	4.85	5.00	5.15	V	Isource = 1 mA
	Line regulation	Vref-line	—	5	20	mV	Isource = 1 mA, VCC = 12 V to 23 V
	Load regulation	Vref-load	—	5	20	mV	Isource = 1 mA to 5 mA
	Temperature stability	dVref	—	±80	—	ppm/°C	Ta = -40 to 125°C * ¹
Oscillator	Initial accuracy	fout	58.5	65	71.5	kHz	Measured pin: OUT
	fout temperature stability	dfout/dTa	—	±0.1	—	%/°C	Ta = -40 to 125°C * ¹
	fout voltage stability	fout-line	-1.5	0.5	1.5	%	VCC = 12 V to 18 V
	CT peak voltage	Vct-H	—	3.6	4.0	V	* ¹
	Ramp valley voltage	Vct-L	—	0.65	—	V	* ¹
	RT voltage	Vrt	1.07	1.25	1.43	V	
Soft start	Sink current	Iss	15.0	25.0	35.0	μA	SS = 2 V
Current limit	Threshold voltage1	VCL1	-0.33	-0.30	-0.27	V	PFC-ON = 2 V
	Delay to output	td-CL	—	280	500	ns	CS = 0 to -1 V
VAMP	Feedback voltage	Vfb	2.40	2.50	2.60	V	FB-EO Short
	Input bias current	Ifb	-0.3	0	0.3	μA	Measured pin: FB
	Open loop gain	Av-v	—	60	—	dB	* ¹
	High voltage	Veoh	5.2	5.7	6.2	V	FB = 2.3 V, EO: Open
	Low voltage	Veol	—	0.1	0.3	V	FB = 2.7 V, EO: Open
	Source current	Isrc-eo	—	-120	—	μA	FB = 1.0 V, EO = 2.5 V
	Sink current	Isnk-eo	—	120	—	μA	FB = 4.0 V, EO = 2.5 V
	Transconductance	Gm-v	150	200	290	μA/V	FB = 2.5 V, EO = 2.5 V
CAMP	Input offset voltage	Vio-ca	—	(-10)	0	mV	* ¹
	Open loop gain	Av-ca	—	60	—	dB	* ¹
	High voltage	Vcaoh	5.2	5.7	6.2	V	
	Low voltage	Vcaol	—	0.1	0.3	V	
	Source current	Isrc-ca	—	-90	—	μA	CAO = 2.5 V * ¹
	Sink current	Isnk-ca	—	90	—	μA	CAO = 2.5 V * ¹
	Transconductance	Gm-c	150	200	290	μA/V	* ¹

Note: 1. Design spec.

(Ta = 25°C, VCC = 12 V, RT = 27 kΩ, CT = 1000 pF)

Item		Symbol	Min	Typ	Max	Unit	Test Conditions
IAC/ Multiplier	IAC PIN voltage	Viac	1.6	2.3	3.0	V	IAC = 100 μA
	Terminal offset current	Imo-offset	-136	-90	-73	μA	IAC = 0 A, CS = 0 V
	Output current (PFC-ON = 2.5 V)	Imo1	—	-20	—	μA	EO = 2 V, IAC = 100 μA * ^{1,2}
		Imo2	—	-60	—	μA	EO = 4 V, IAC = 100 μA * ^{1,2}
	Output current (PFC-ON = 5.5 V)	Imo3	—	-5	—	μA	EO = 2 V, IAC = 100 μA * ^{1,2}
		Imo4	—	-15	—	μA	EO = 4 V, IAC = 100 μA * ^{1,2}
	PFC-CS resistance	Rmo	—	3.3	—	kΩ	* ¹
Gain voltage	Vpfc-gain	(3.4)	(4.1)	(4.7)	V	Gain = 0.125* ¹	
OUT	Minimum duty cycle	Dmin-out	—	—	0	%	CAO = 4.0 V
	Maximum duty cycle	Dmax-out	90	95	98	%	CAO = 0 V
	Rise time	tr-out	—	30	100	ns	CL = 1000 pF
	Fall time	tf-out	—	30	100	ns	CL = 1000 pF
	Low voltage	Vol1-out	—	0.05	0.2	V	Iout = 20 mA
		Vol2-out	—	0.5	2.0	V	Iout = 200 mA (Pulse Test)
		Vol3-out	—	0.03	0.7	V	Iout = 10 mA, VCC = 5 V
	High voltage	Voh1-out	11.5	11.9	—	V	Iout = -20 mA
Voh2-out		10.0	11.0	—	V	Iout = -200 mA (Pulse Test)	

- Notes: 1. Design spec.
 2. Imo1 to Imo4 defined as,
 $I_{mo} = (CS \text{ Terminal Current}) - (I_{mo-offset})$

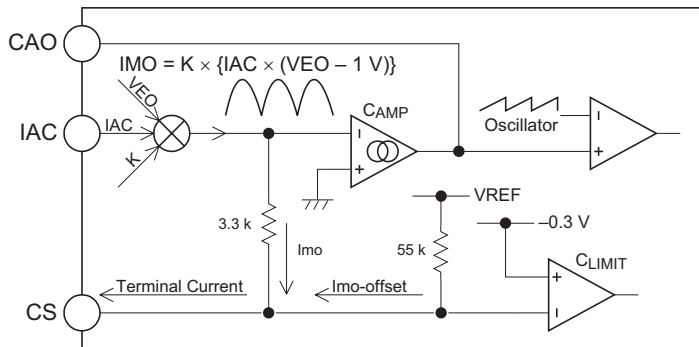

(Ta = 25°C, VCC = 12 V, RT = 27 kΩ, CT = 1000 pF)

Item	Symbol	Min	Typ	Max	Unit	Test Conditions	
Supervisor/ PG	PFC enable voltage	Von-pfc	1.62	1.75	1.87	V	Input pin: PFC-ON
	PFC disable voltage	Voff-pfc	1.48	1.6	1.72	V	Input pin: PFC-ON
	Input current	Ipfc-on	—	0.1	1.0	μA	PFC-ON = 2 V
	B+ OVP set voltage	dVovps	0.125	0.188	0.250	V	Input pin: FB * ¹
	B+ OVP reset voltage	dVovpr	0.075	0.138	0.200	V	Input pin: FB * ¹
	FB low set voltage	Vfbls	0.45	0.50	0.55	V	Input pin: FB

Note: 1. $dVovps = Vovps - Vref \times 0.5$
 $dVovpr = Vovpr - Vref \times 0.5$

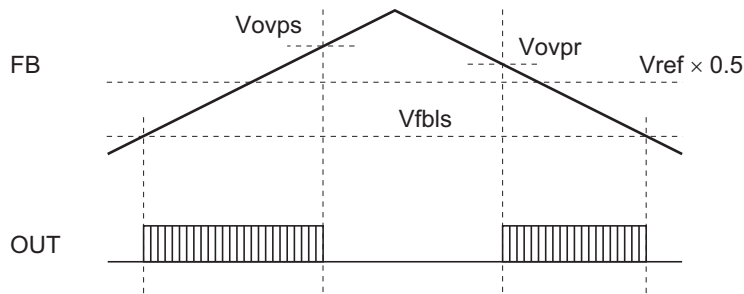

Timing Chart

1. Start-up Timing

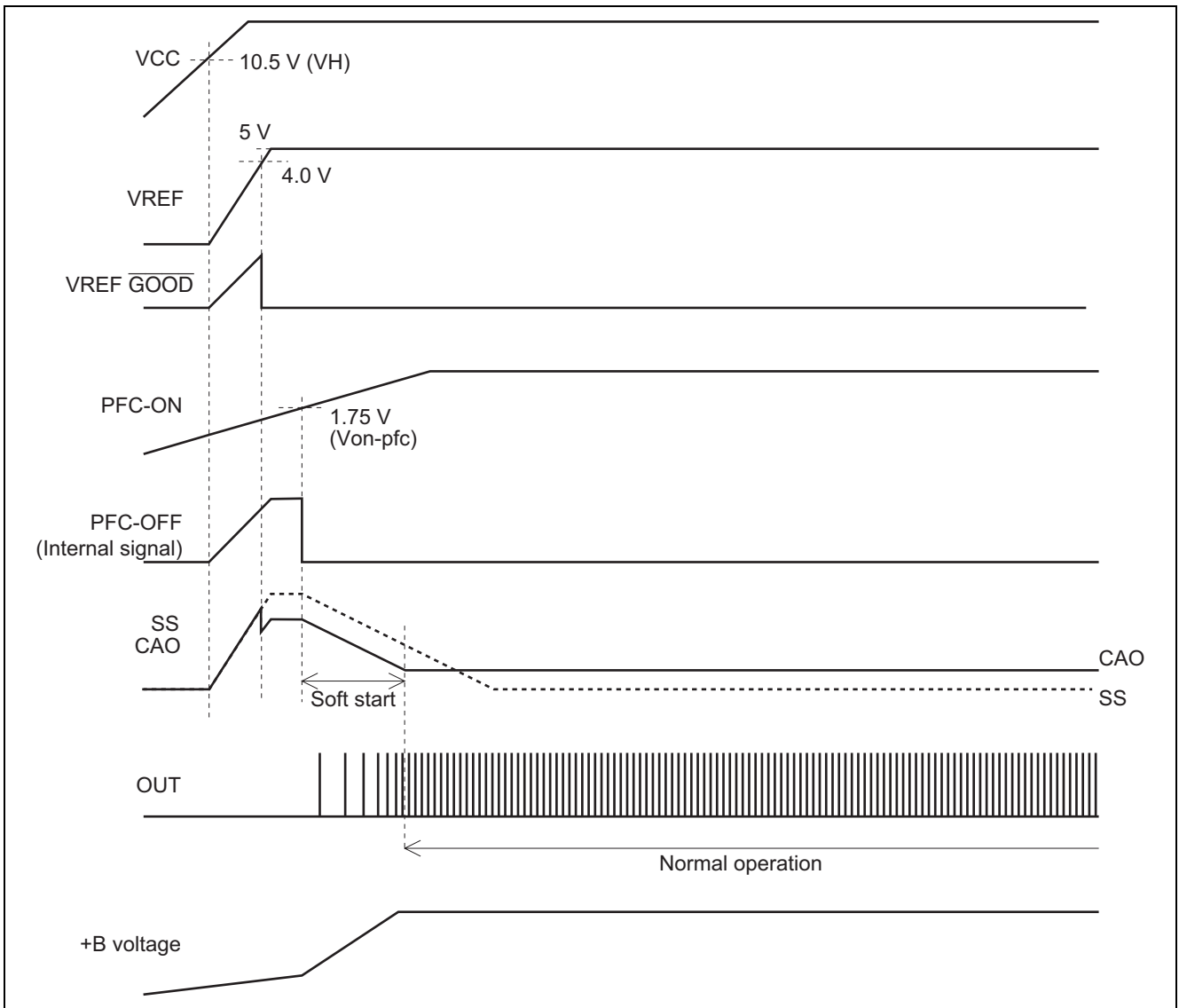

2. Oscillator, Gate Driver Output

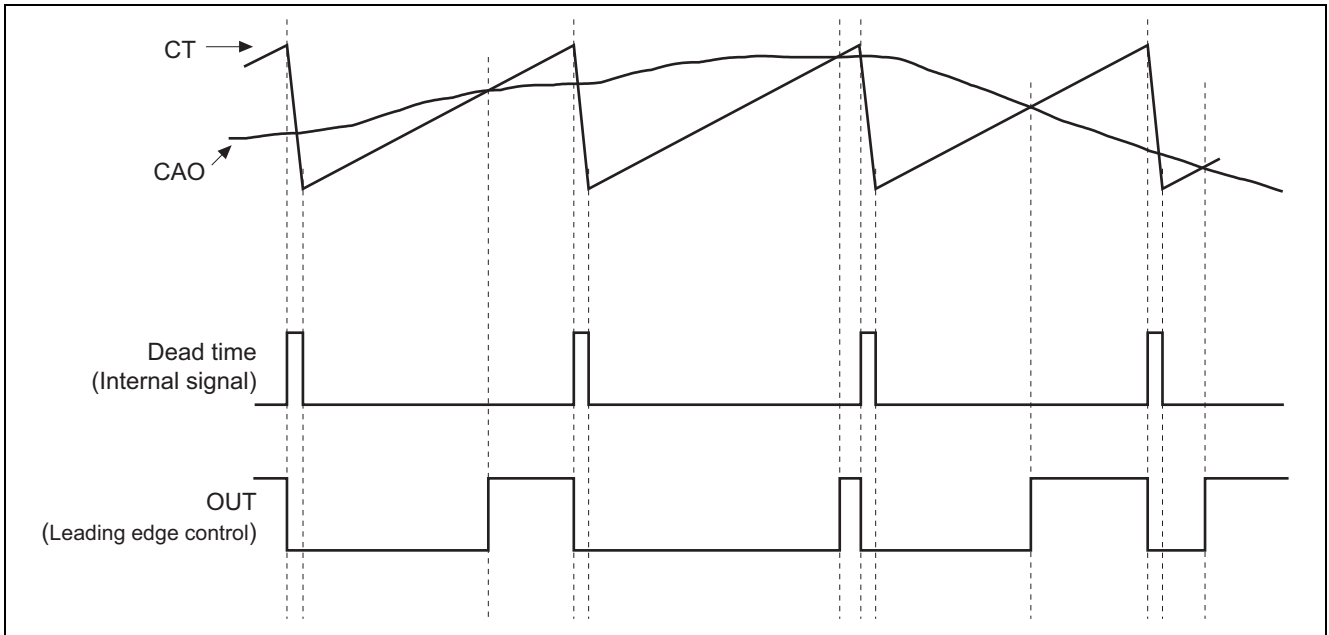

3. PFC Operation ON/OFF

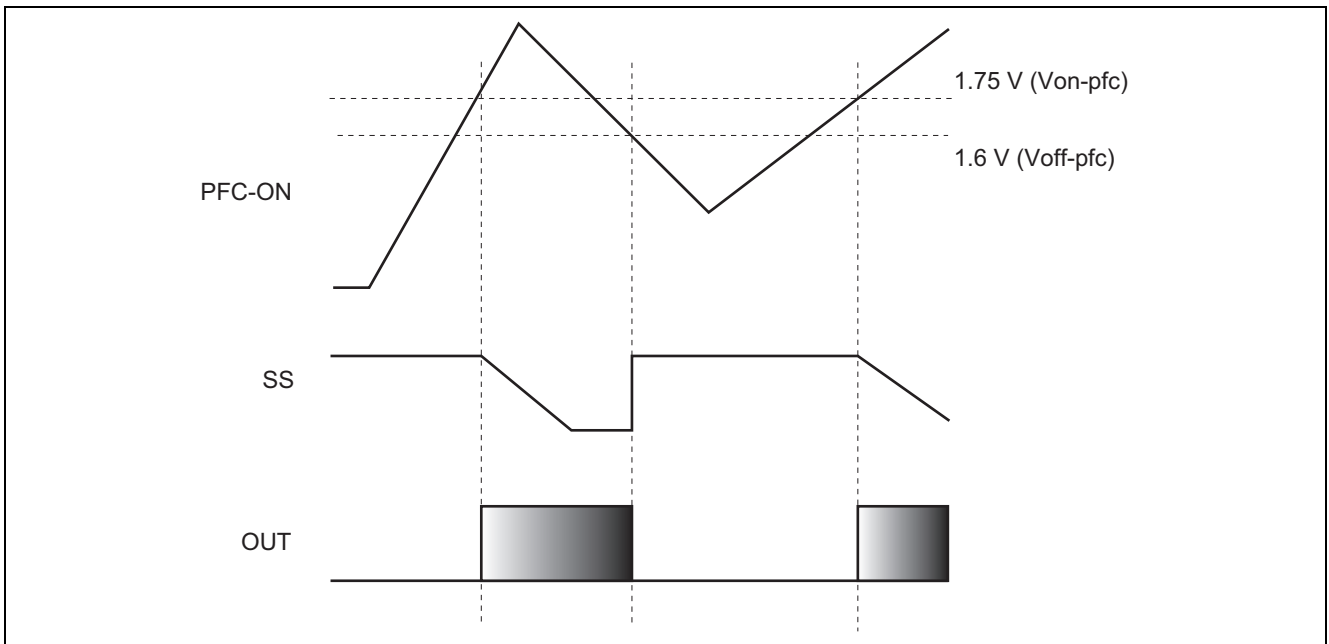

4. FB Supervisor

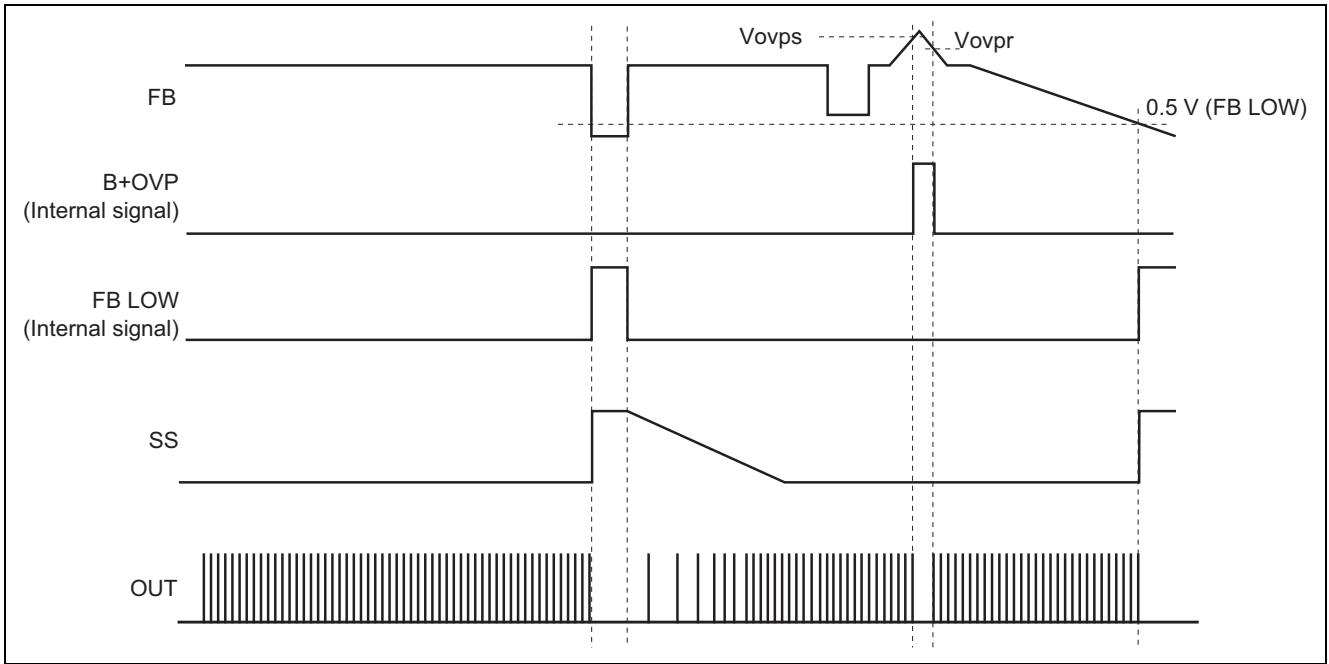

5. PFC ON/OFF Function

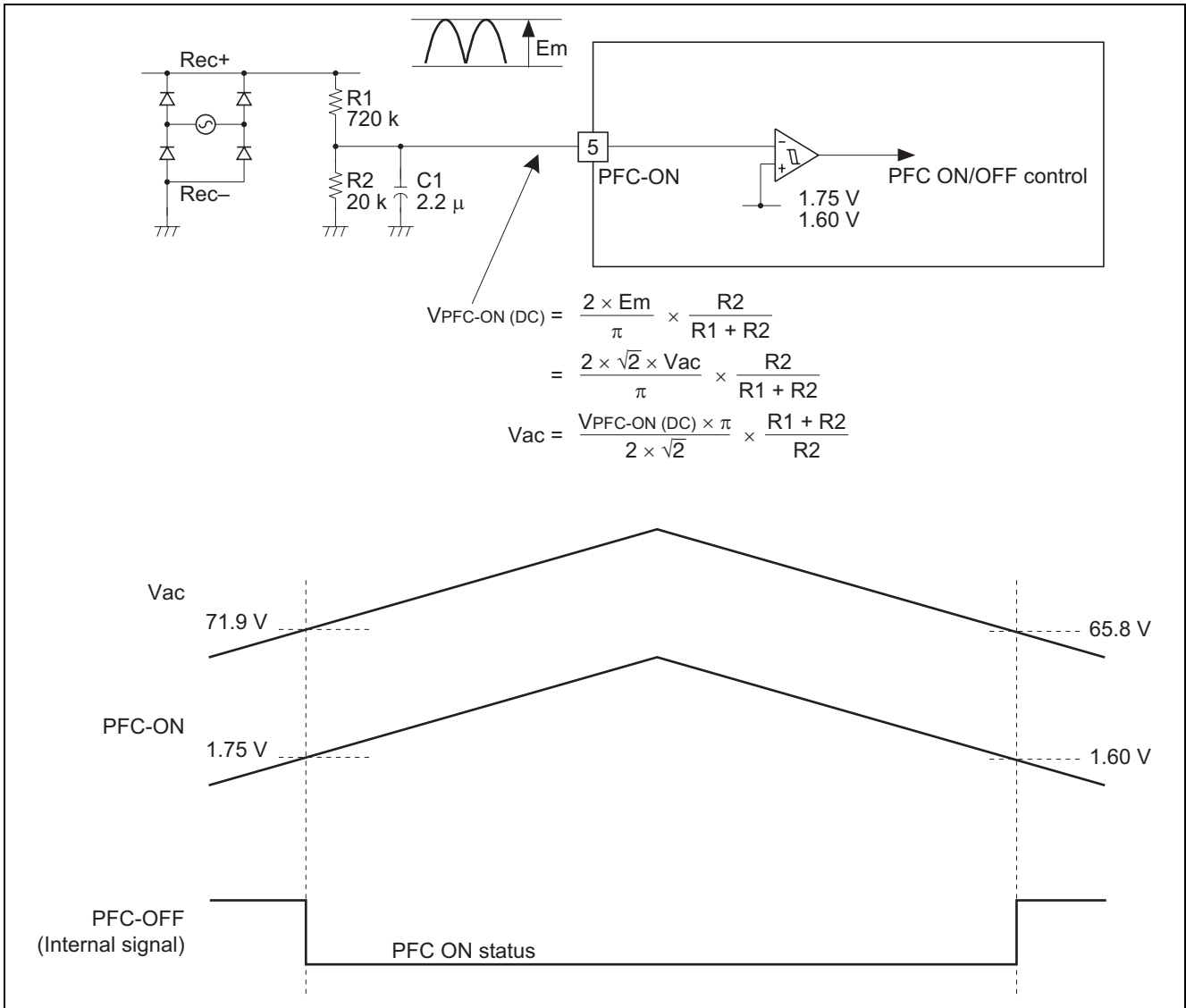

Description of Pin Functions

OUT Pin:

The power MOS FET gate-drive signal is output from this pin, and takes the form of a rectangular waveform with an amplitude of VCC-GND.

PGND Pin:

The ground terminal for OUT driver.

SGND Pin:

The ground terminal for internal circuits.

PFC-ON Pin:

This pin is applied smoothing voltage of rectified AC voltage. When 1.75 V (typ.) or more is applied to this pin, PFC operation starts. When the voltage is 1.6 V (typ.) or lower, the PFC operation stops.

VREF Pin:

Temperature-compensated voltage with an accuracy of $5\text{ V} \pm 3\%$ is output from this pin. The pin should supply no more than 5 mA (max.) source current. This pin has no sink capabilities.

CAO Pin:

This pin is the current-error amplifier output, and is connected to the phase-compensation circuit of the current-error amp. The result of comparison of the voltage on this pin and the CT pin produces the pulse output from the OUT pin.

CS Pin:

Current detection pin. The current is controlled to be proportional to the AC voltage and the power factor is corrected. When the voltage on this pin drops to -0.3 V (typ.) or below, over current detection circuit operates, and OUT pin is stopped.

RT Pin:

A pin for frequency adjustment of the oscillator.

CT Pin:

A pin for frequency adjustment of the oscillator.

IAC Pin:

This pin is for detecting the input AC voltage waveform. For processing within the IC, the AC voltage waveform is converted to current information.

FB Pin:

This pin is the input to the voltage error amp. This pin is applied to voltage divided PFC output with resistors. The feedback loop is intended to keep 2.5 V (typ.).

EO Pin:

This pin is the output of the voltage error amp. This pin is connected to the phase-compensation circuit of the voltage error amp. The voltage on this pin is the input signal to the internal multiplier.

SS Pin:

This pin is connected to GND or VREF via a capacitor. This pin is pulled up to the VREF pin voltage until PFC operation starts. When the voltage on the PFC-ON pin has reached 1.75 V (typ.) PFC operation is start and this pin flows 25 μA source current. Operation of the CAO pin is affected by that of the SS pin, the pulse width of the OUT pin is limited, and this prevents overshooting when start up.

VCC Pin:

IC power-supply pin. The IC starts up at 10.5 V (typ.), and stops at 9 V (typ.).

Description of Functions

1. UVL Circuit

The UVL circuit monitors the Vcc voltage. When the voltage is lower than 9.0 V, the IC is stopped. When the voltage is higher than 10.5 V, IC is started.

When operation of the IC is stopped by the UVL circuit, the driver circuit output is fixed low, output of VREF is stopped, and the oscillator is stopped.

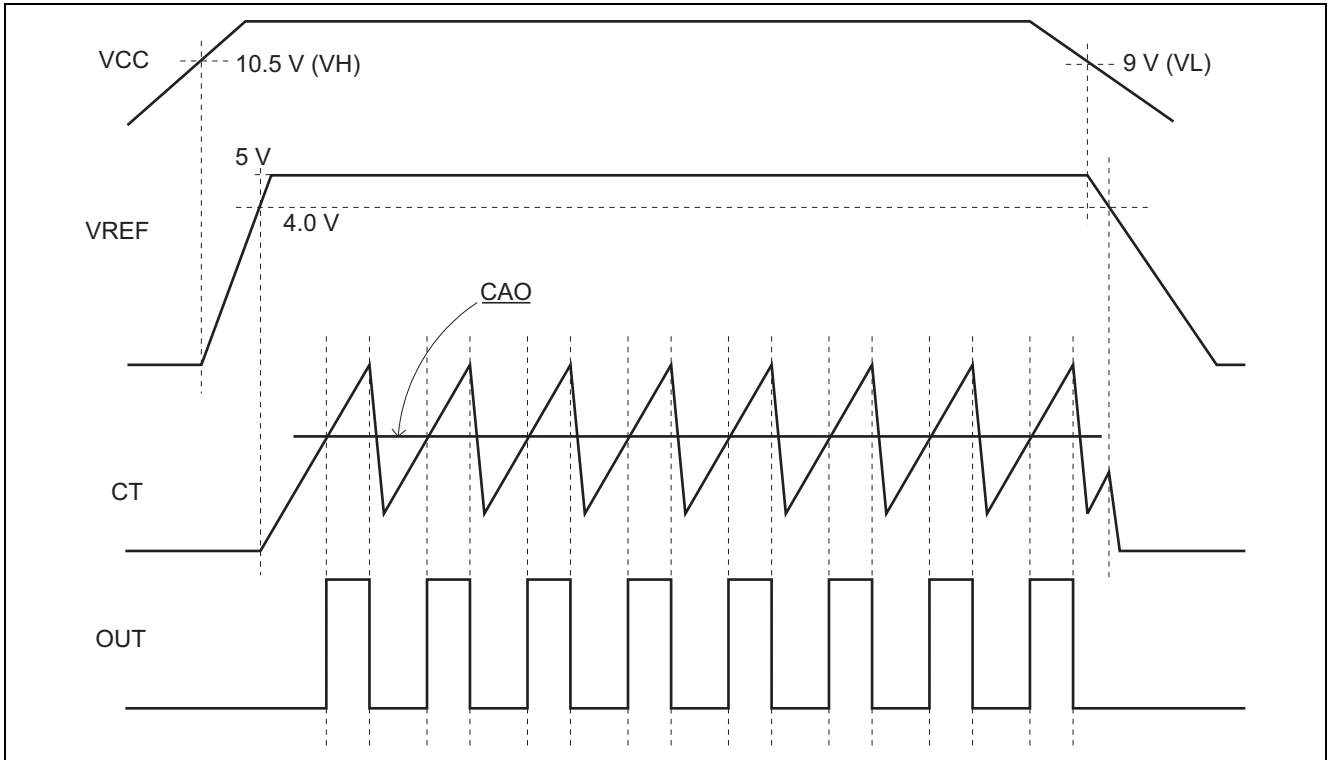

Figure 1 UVL Operation

2. Operating Frequency

The HA16178 operating frequency f_{osc} is determined by adjusting the timing resistor R_t (the RT pin, pin 9) and the timing capacitance C_t (the CT pin, pin 10). The operating frequency is approximated by the following expression:

$$f_{osc} = \frac{1.755 \times 10^6}{R_t (k\Omega) \times C_t (pF)} \text{ (kHz)}$$

When the IC is operated at high frequencies, the expression becomes less accurate due to IC internal delay time, etc. Please confirm operation the value with the actually mounted IC. The maximum operating frequency is 400 kHz. As a reference, the operating frequency data when the timing resistor and the timing capacitance are changed is shown in the below figure.

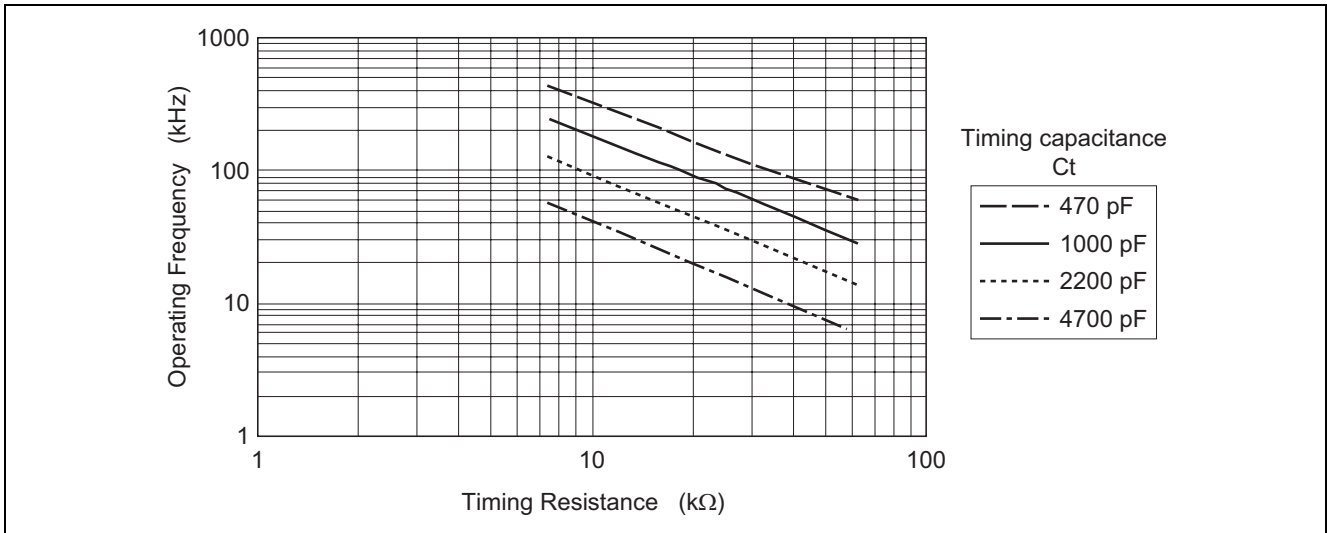

Figure 2 Operating Frequency Characteristics

3. Soft Start

This function prevents applying excessive stress on external components and overshooting of the PFC output voltage (B + voltage) when start up. The pulse width is gradually widening from 0% duty cycle. During soft-start operation, the SS and CAO signals lower with link. The duty cycle is controlled by the CAO signal.

The soft-start time can be set by an external capacity.

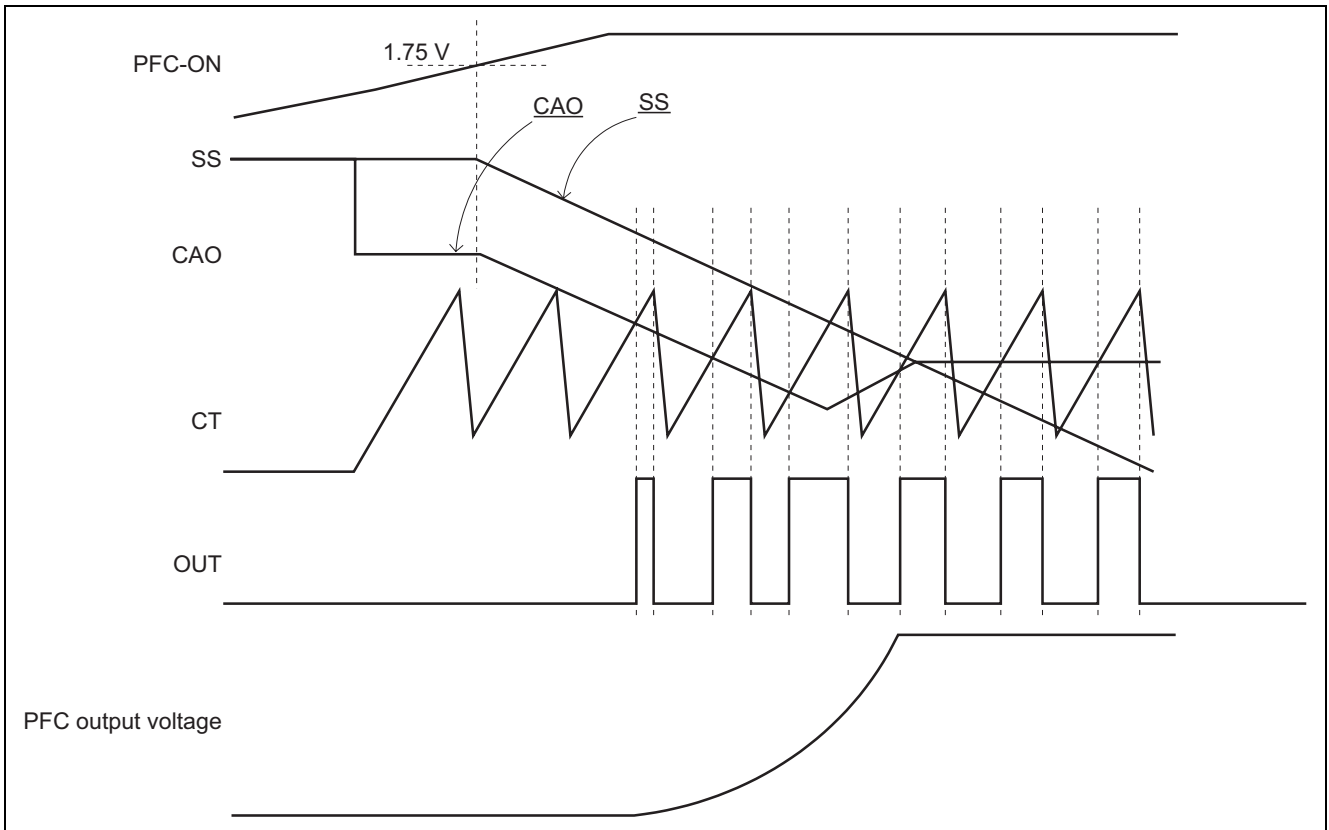
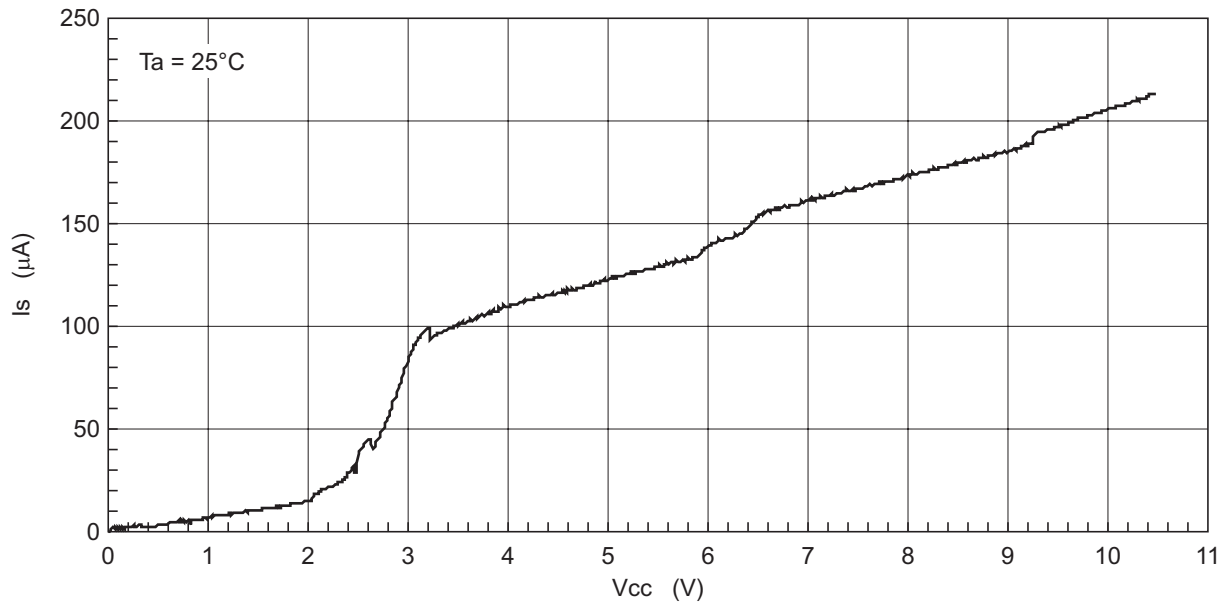

Figure 3 Soft-Start Operation Waveform

Main Characteristics

Standby Current vs. Power Supply Voltage Characteristics



Power Dissipation vs. Power Supply Voltage Characteristics

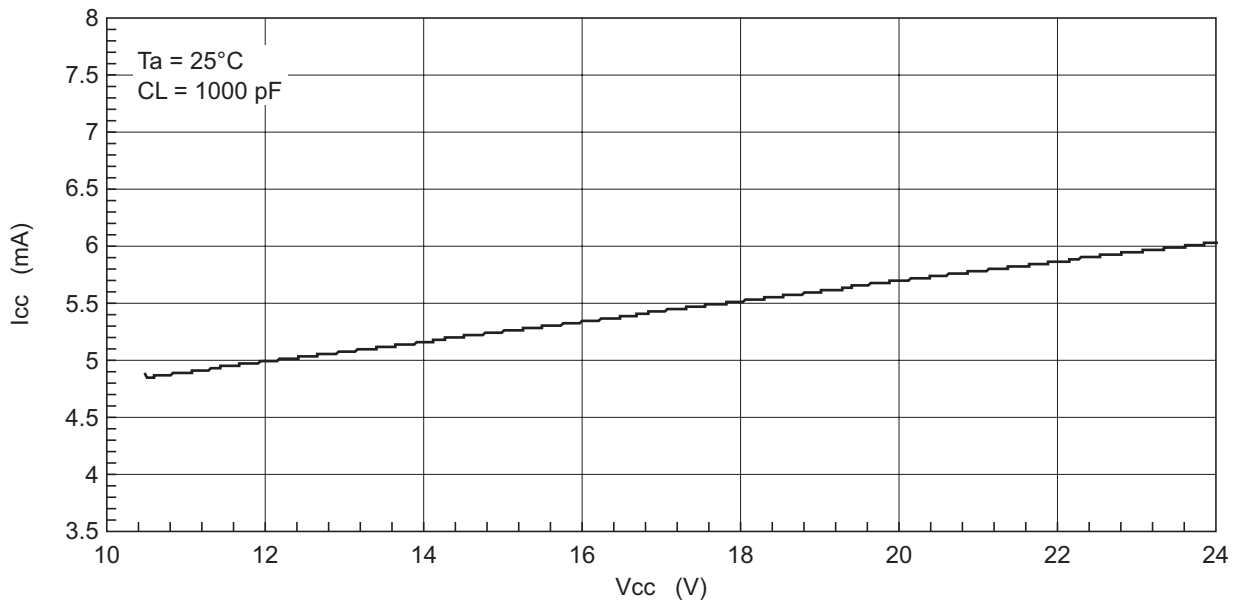

Reference Voltage Temperature Characteristics

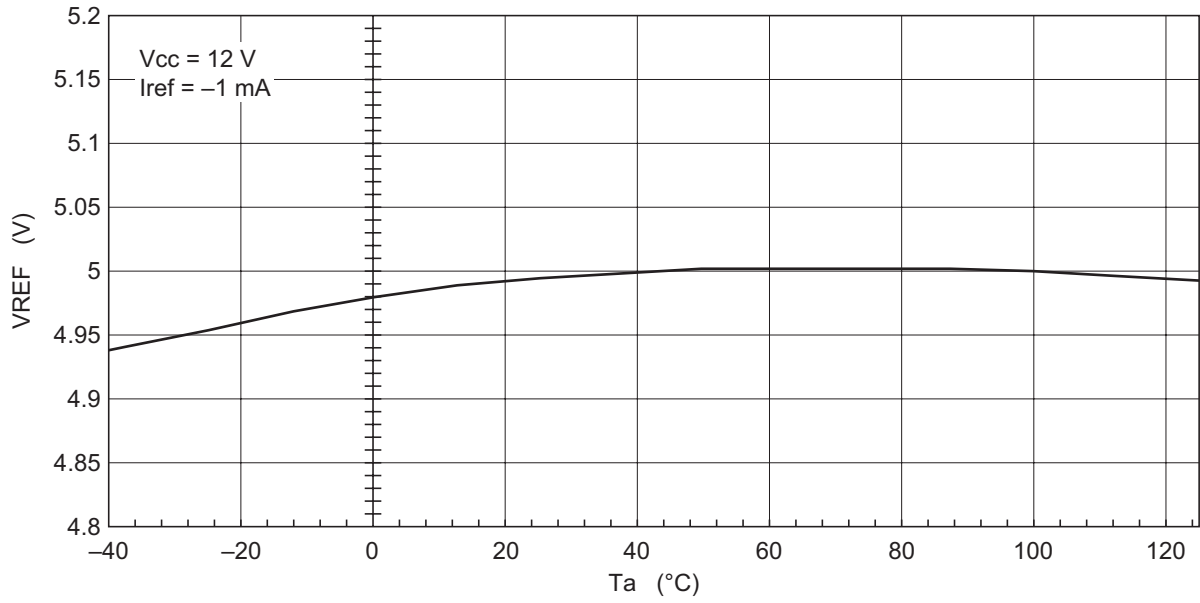

Operating Frequency Temperature Characteristics

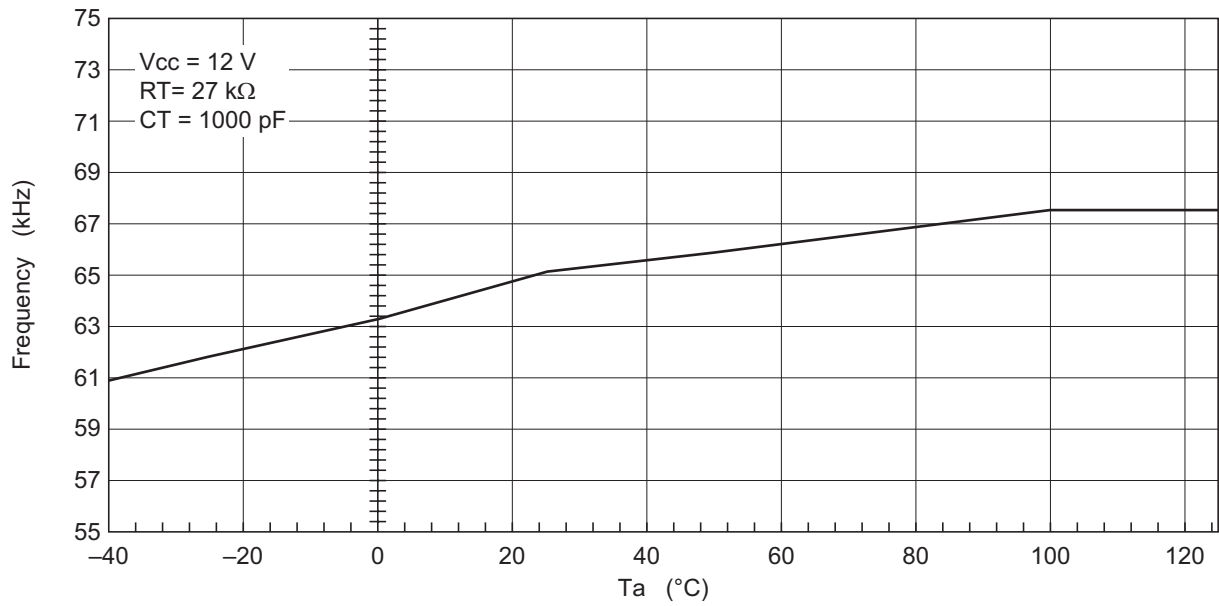

Start-up Voltage Temperature Characteristics

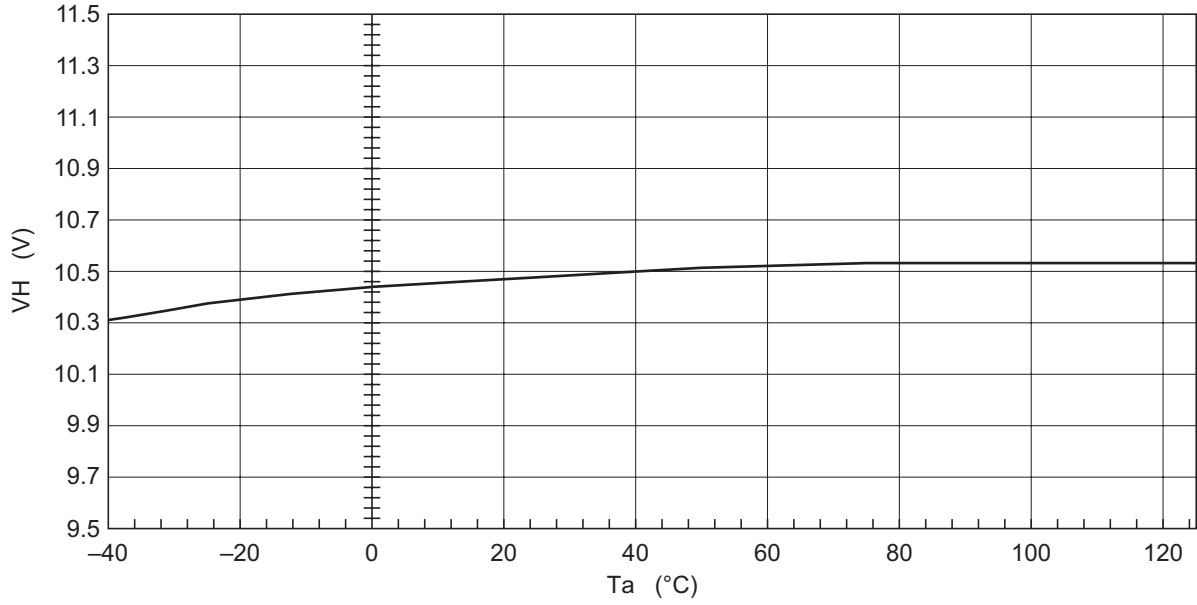

Shutdown Voltage Temperature Characteristics

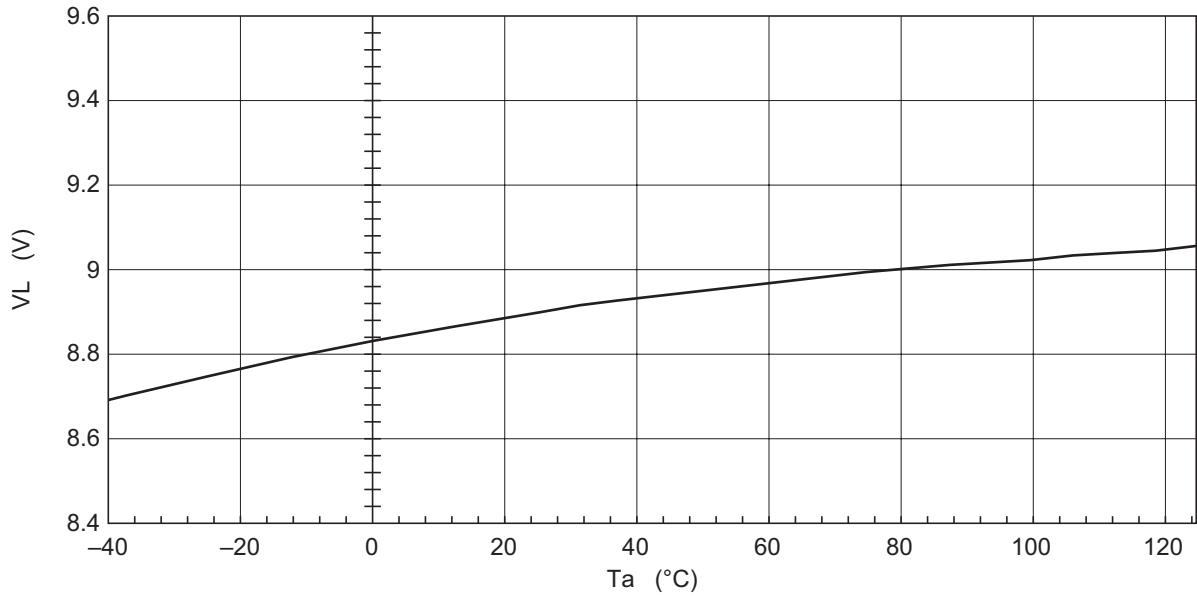

Standby Current Temperature Characteristics

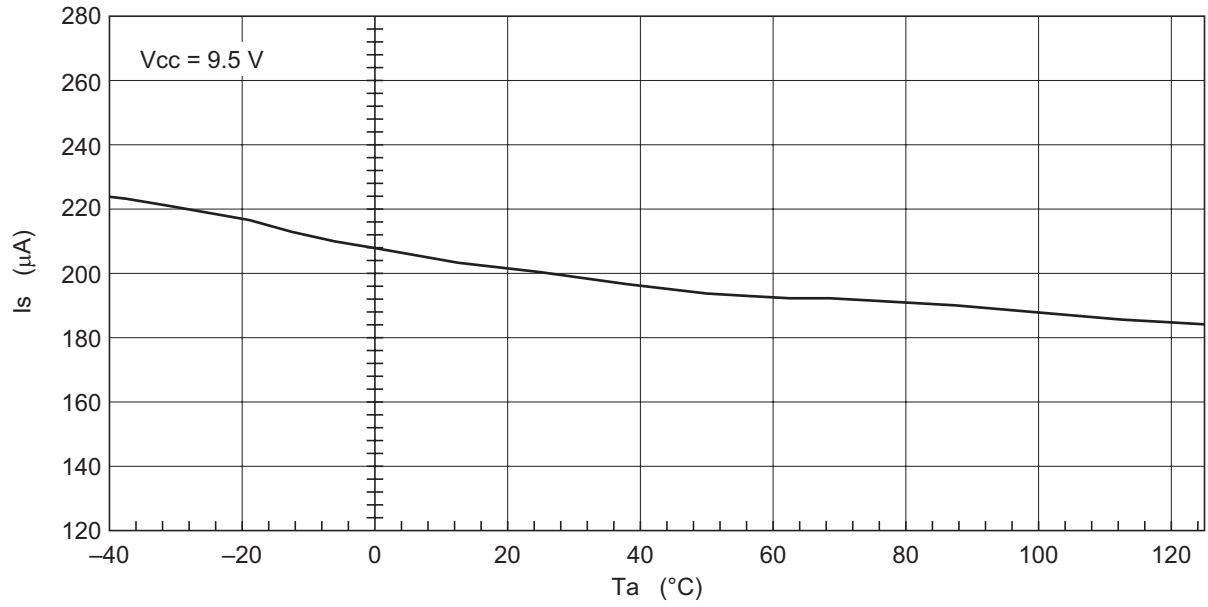

Operating Current Temperature Characteristics

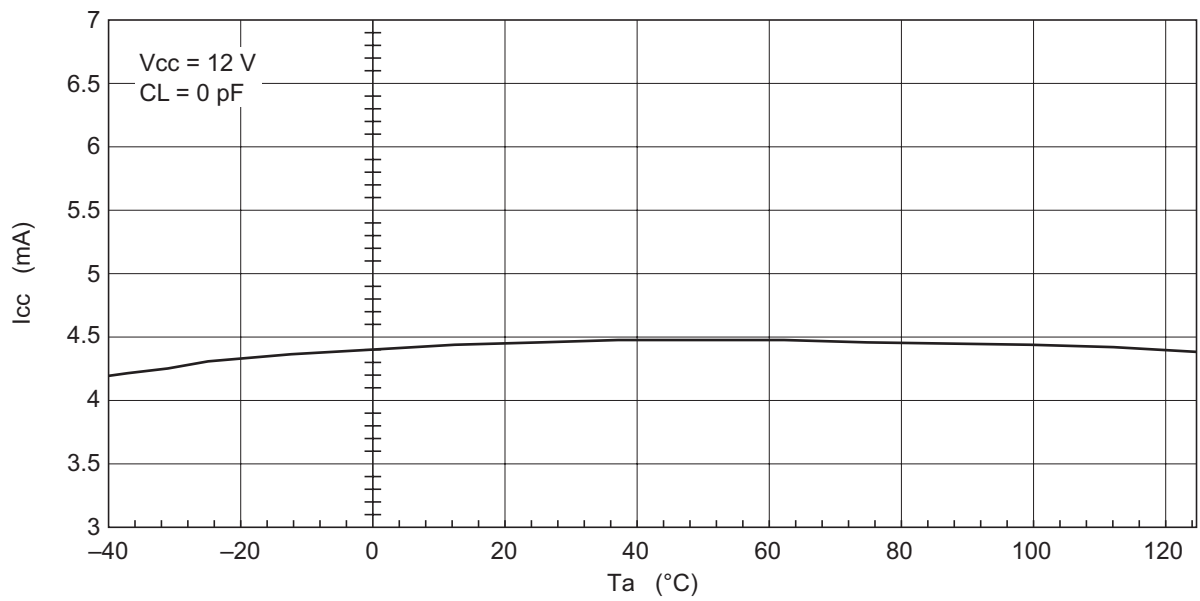

VAMP Feedback Voltage Temperature Characteristics

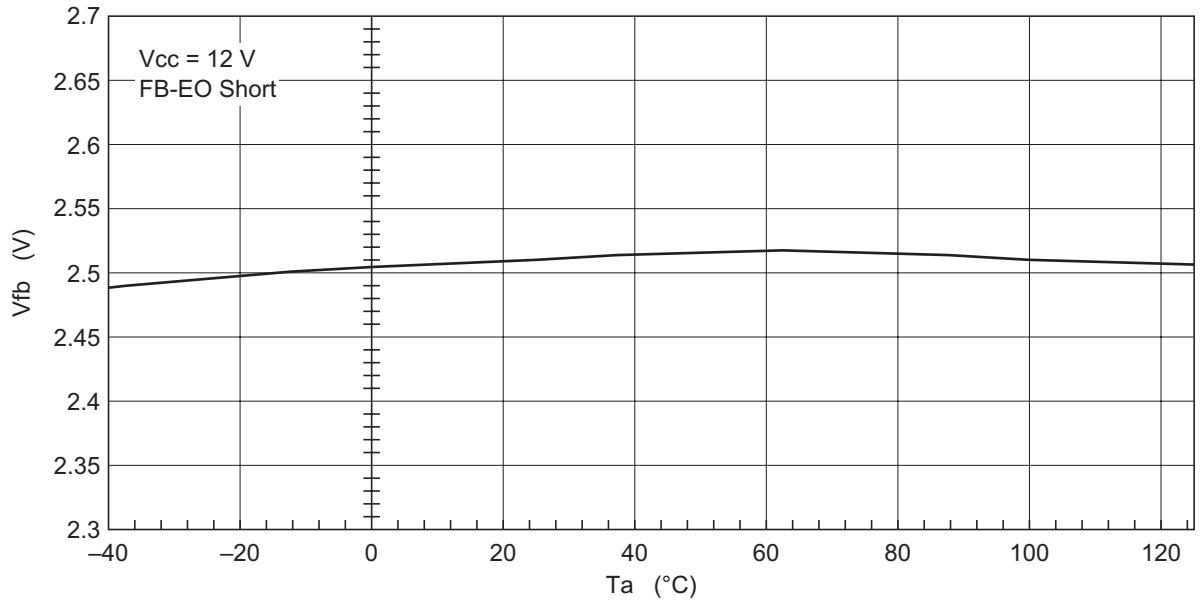

EO Pin Voltage vs. CS Pin Current Characteristics

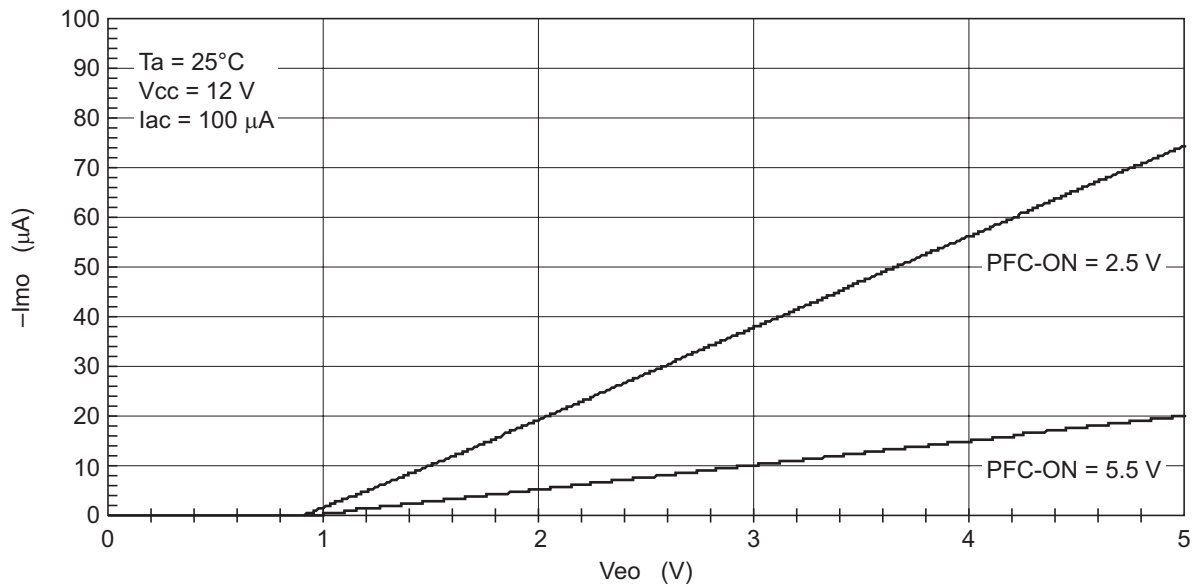

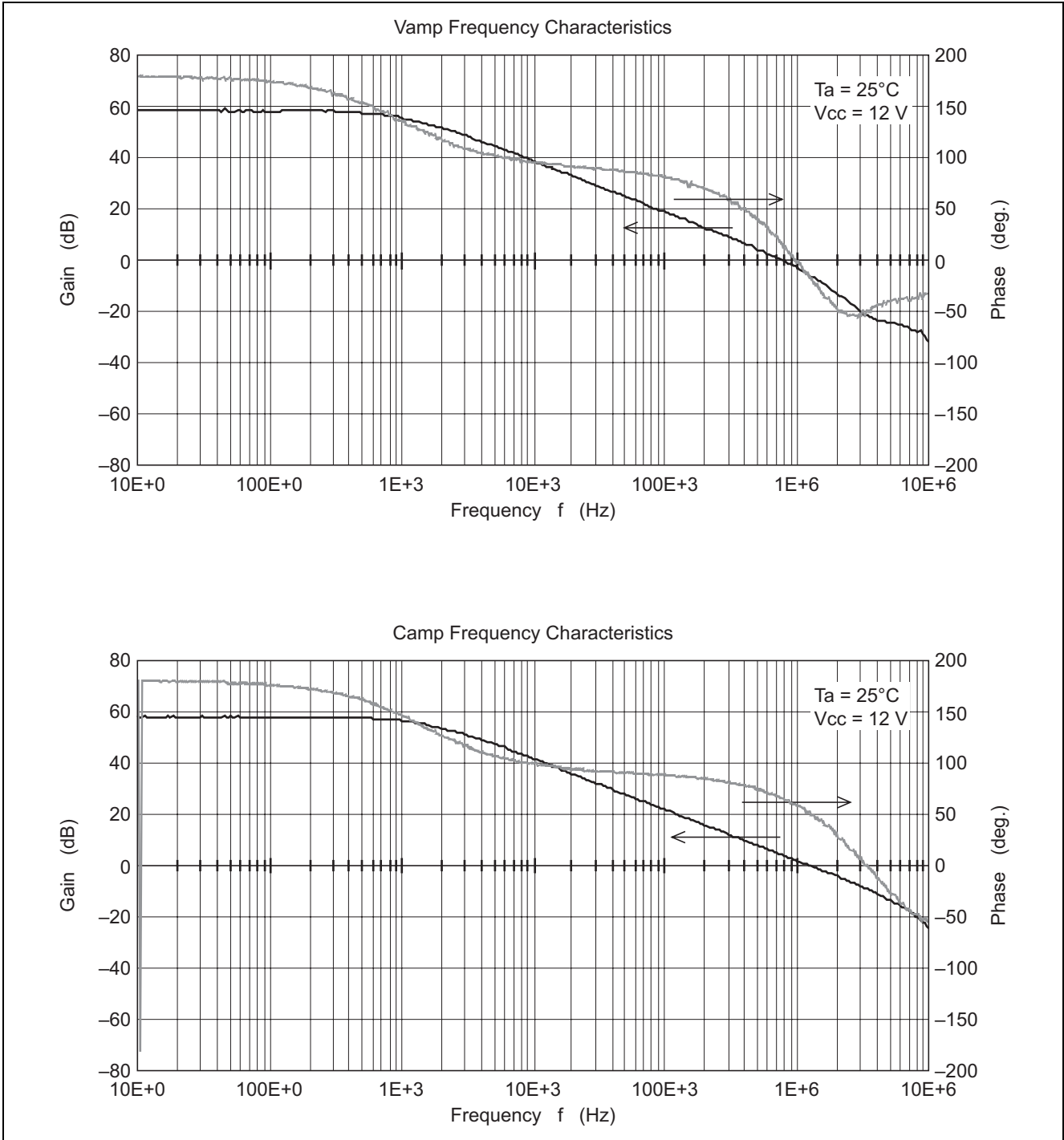

Precautions on Usage

1. CS Pin

The CS pin is used to for detection in PFC control led current. When power supply is started up, the voltage drop of inrush current must not exceed the maximum rated value of the CS pin.

2. VREF Pin

For stabilization, be sure to connect a capacitor between the pin and ground. It possible to occur overshoot of VREF by connected capacitance. The degree of the overshoot will depend on the value of the connected capacitor. Pay particular attention to this point if you intend to use the VREF pin voltage as reference voltage for an external circuit.

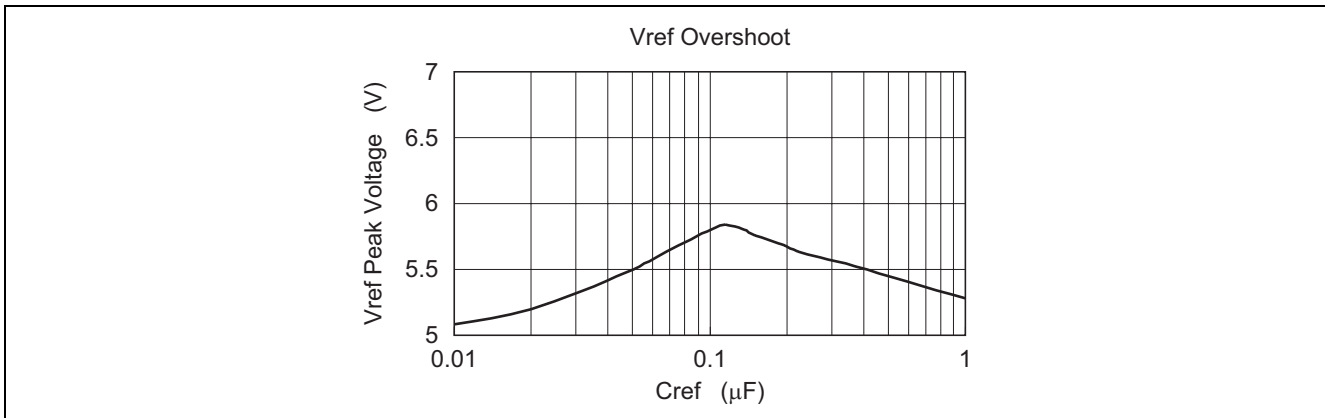

Figure 4 Overshoot on the VREF Pin vs. Capacitance

3. PFC-ON Pin

In design of worldwide power supply, it is possible that calculated voltage exceed maximum rated voltage of PFC-ON pin. Actually, as a clamp circuit is included in the PFC-ON pin, the voltage is clamped however, clamp current must not exceed 300 μA.

4. OUT Pin

Undershooting or overshooting may occur due to the wiring of the OUT pin. These may bring to malfunctions of the IC. In such a case, prevent the undershooting or overshooting by using a Schottky barrier diode, etc.

5. Pattern Layout

In designing the pattern layout, pay as much attention as is possible to the following points.

- (1) Place the stabilizing capacitor for the VREF pin as close to the IC as possible, and keep the wiring short.
- (2) Place the timing resistor of the RT pin as close to the IC as possible, and keep the wiring short.
- (3) Place the phase compensation circuit for the CAO pin as close to the IC as possible, and keep the wiring short.
- (4) Place the timing capacitor for the CT pin as close to the IC as possible, and keep the wiring short.
- (5) Place the stabilizing capacitor for the VCC pin as close to the IC as possible, and keep the wiring short.
- (6) Place the IC pins and their wiring as far from high-voltage switching lines (particularly the drain voltage for the power MOS FET) as possible and in general design the wiring to minimize switching noise.
- (7) It is probable that stability of operation is achieved by inputting signals via filters to pins with input functions. Note, however, that such filter circuits can affect the bias conditions for pins that have both input and output functions.

6. About NC Terminal

NC terminal uses open.

System Diagram

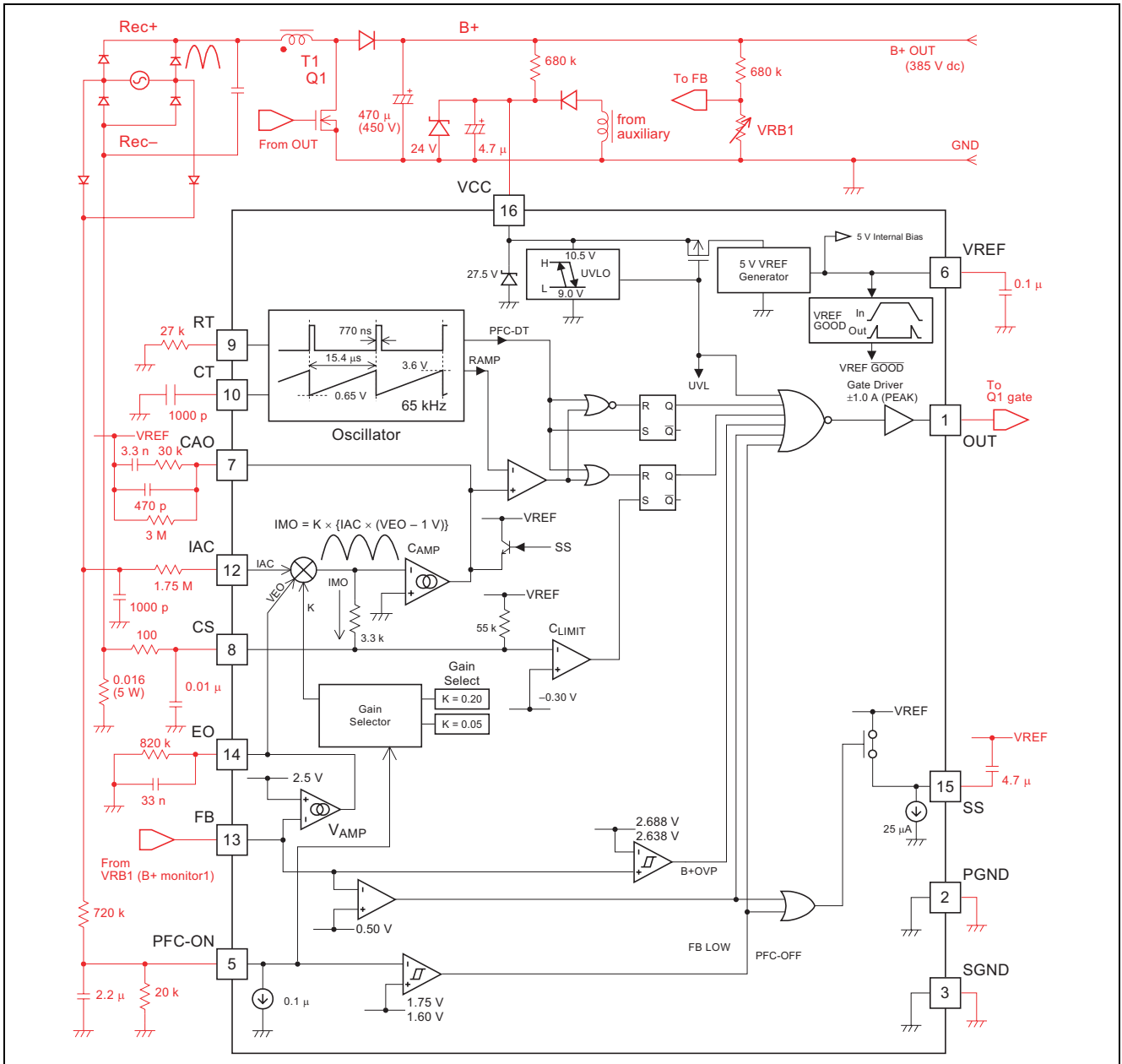

Package Dimensions

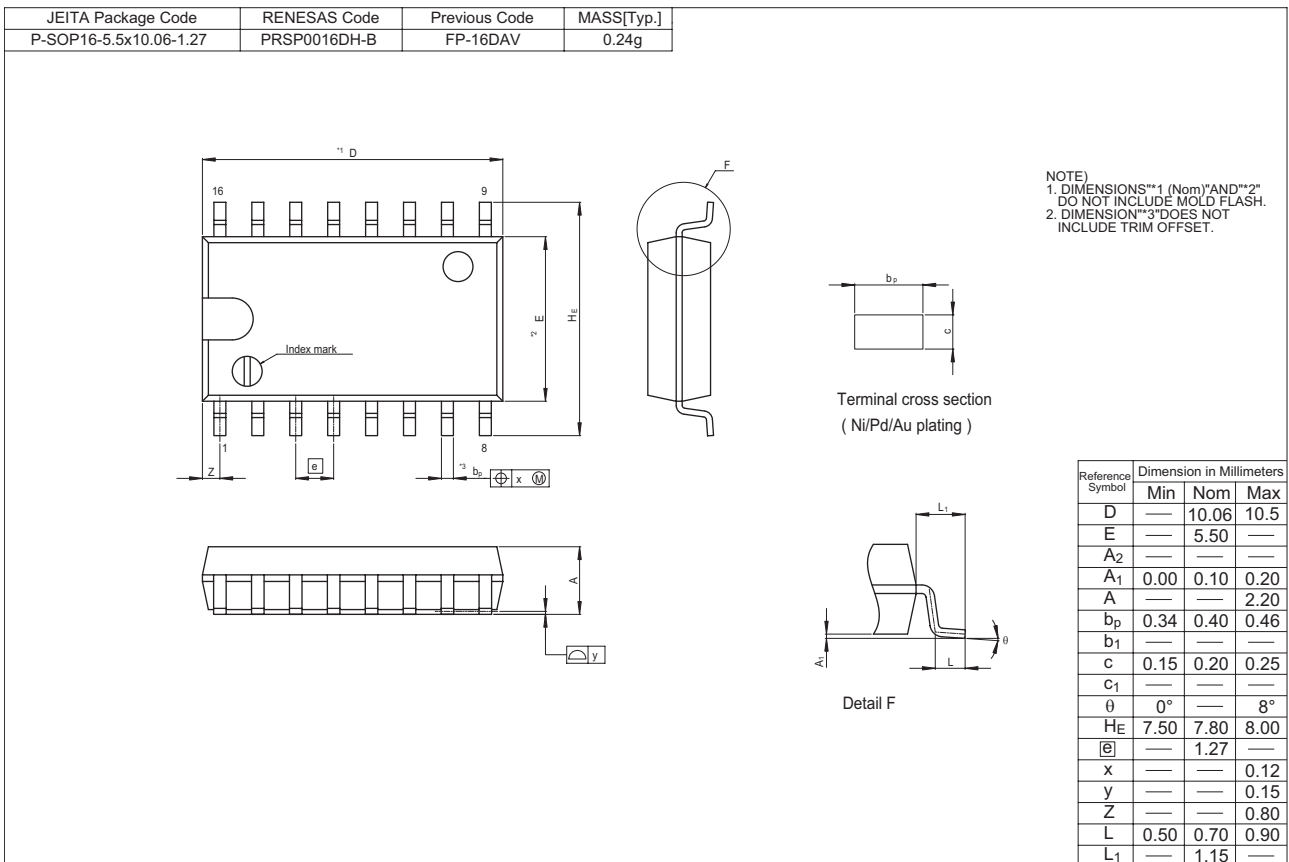
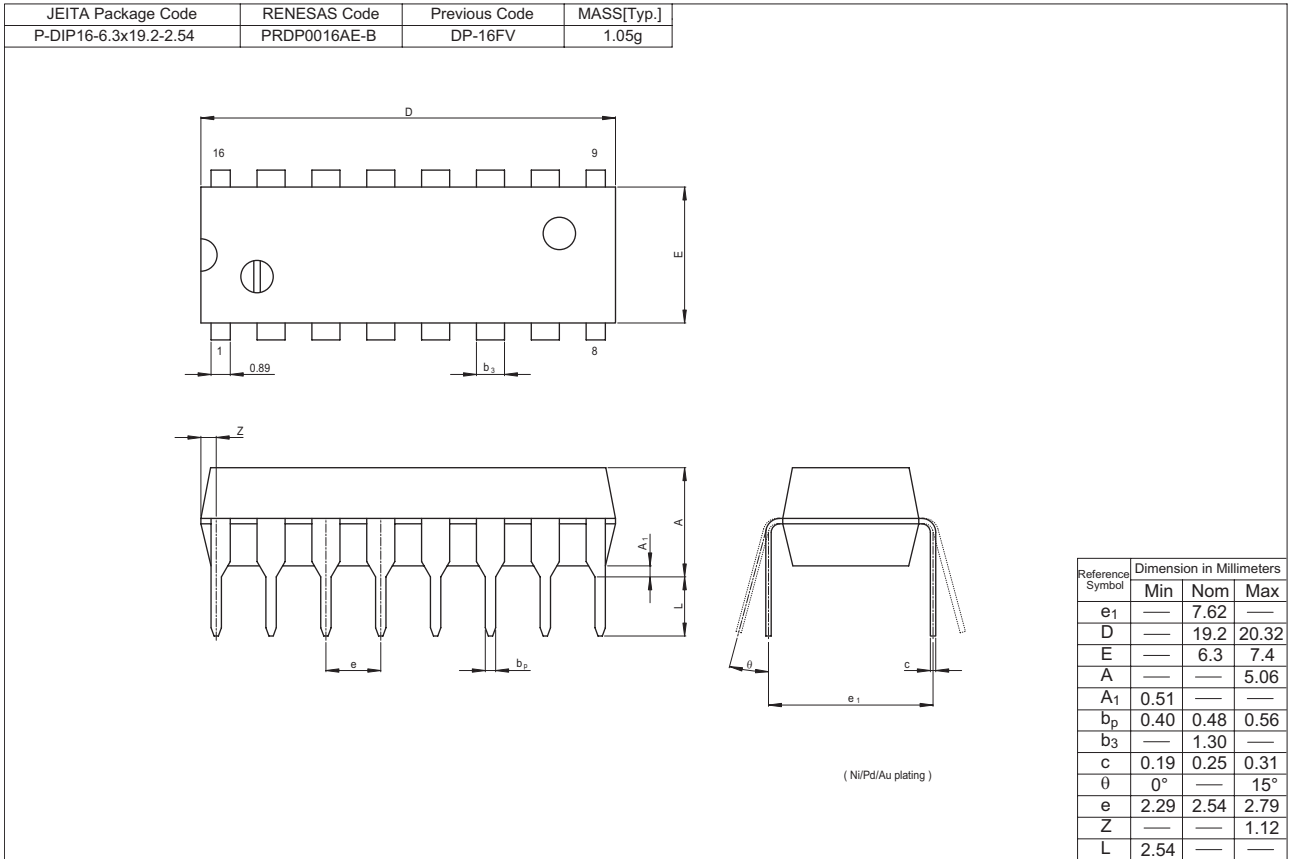

Notes:

1. This document is provided for reference purposes only so that Renesas customers may select the appropriate Renesas products for their use. Renesas neither makes warranties or representations with respect to the accuracy or completeness of the information contained in this document nor grants any license to any intellectual property rights or any other rights of Renesas or any third party with respect to the information in this document.
2. Renesas shall have no liability for damages or infringement of any intellectual property or other rights arising out of the use of any information in this document, including, but not limited to, product data, diagrams, charts, programs, algorithms, and application circuit examples.
3. You should not use the products or the technology described in this document for the purpose of military applications such as the development of weapons of mass destruction or for the purpose of any other military use. When exporting the products or technology described herein, you should follow the applicable export control laws and regulations, and procedures required by such laws and regulations.
4. All information included in this document such as product data, diagrams, charts, programs, algorithms, and application circuit examples, is current as of the date this document is issued. Such information, however, is subject to change without any prior notice. Before purchasing or using any Renesas products listed in this document, please confirm the latest product information with a Renesas sales office. Also, please pay regular and careful attention to additional and different information to be disclosed by Renesas such as that disclosed through our website. (<http://www.renesas.com>)
5. Renesas has used reasonable care in compiling the information included in this document, but Renesas assumes no liability whatsoever for any damages incurred as a result of errors or omissions in the information included in this document.
6. When using or otherwise relying on the information in this document, you should evaluate the information in light of the total system before deciding about the applicability of such information to the intended application. Renesas makes no representations, warranties or guarantees regarding the suitability of its products for any particular application and specifically disclaims any liability arising out of the application and use of the information in this document or Renesas products.
7. With the exception of products specified by Renesas as suitable for automobile applications, Renesas products are not designed, manufactured or tested for applications or otherwise in systems the failure or malfunction of which may cause a direct threat to human life or create a risk of human injury or which require especially high quality and reliability such as safety systems, or equipment or systems for transportation and traffic, healthcare, combustion control, aerospace and aeronautics, nuclear power, or undersea communication transmission. If you are considering the use of our products for such purposes, please contact a Renesas sales office beforehand. Renesas shall have no liability for damages arising out of the uses set forth above.
8. Notwithstanding the preceding paragraph, you should not use Renesas products for the purposes listed below:
 - (1) artificial life support devices or systems
 - (2) surgical implantations
 - (3) healthcare intervention (e.g., excision, administration of medication, etc.)
 - (4) any other purposes that pose a direct threat to human lifeRenesas shall have no liability for damages arising out of the uses set forth in the above and purchasers who elect to use Renesas products in any of the foregoing applications shall indemnify and hold harmless Renesas Technology Corp., its affiliated companies and their officers, directors, and employees against any and all damages arising out of such applications.
9. You should use the products described herein within the range specified by Renesas, especially with respect to the maximum rating, operating supply voltage range, movement power voltage range, heat radiation characteristics, installation and other product characteristics. Renesas shall have no liability for malfunctions or damages arising out of the use of Renesas products beyond such specified ranges.
10. Although Renesas endeavors to improve the quality and reliability of its products, IC products have specific characteristics such as the occurrence of failure at a certain rate and malfunctions under certain use conditions. Please be sure to implement safety measures to guard against the possibility of physical injury, and injury or damage caused by fire in the event of the failure of a Renesas product, such as safety design for hardware and software including but not limited to redundancy, fire control and malfunction prevention, appropriate treatment for aging degradation or any other applicable measures. Among others, since the evaluation of microcomputer software alone is very difficult, please evaluate the safety of the final products or system manufactured by you.
11. In case Renesas products listed in this document are detached from the products to which the Renesas products are attached or affixed, the risk of accident such as swallowing by infants and small children is very high. You should implement safety measures so that Renesas products may not be easily detached from your products. Renesas shall have no liability for damages arising out of such detachment.
12. This document may not be reproduced or duplicated, in any form, in whole or in part, without prior written approval from Renesas.
13. Please contact a Renesas sales office if you have any questions regarding the information contained in this document, Renesas semiconductor products, or if you have any other inquiries.



RENESAS SALES OFFICES

<http://www.renesas.com>

Refer to "<http://www.renesas.com/en/network>" for the latest and detailed information.

Renesas Technology America, Inc.
450 Holger Way, San Jose, CA 95134-1368, U.S.A
Tel: <1> (408) 382-7500, Fax: <1> (408) 382-7501

Renesas Technology Europe Limited
Dukes Meadow, Millboard Road, Bourne End, Buckinghamshire, SL8 5FH, U.K.
Tel: <44> (1628) 585-100, Fax: <44> (1628) 585-900

Renesas Technology (Shanghai) Co., Ltd.
Unit 204, 205, AZIA Center, No.1233 Lujiazui Ring Rd, Pudong District, Shanghai, China 200120
Tel: <86> (21) 5877-1818, Fax: <86> (21) 6887-7898

Renesas Technology Hong Kong Ltd.
7th Floor, North Tower, World Finance Centre, Harbour City, 1 Canton Road, Tsimshatsui, Kowloon, Hong Kong
Tel: <852> 2265-6688, Fax: <852> 2730-6071

Renesas Technology Taiwan Co., Ltd.
10th Floor, No.99, Fushing North Road, Taipei, Taiwan
Tel: <886> (2) 2715-2888, Fax: <886> (2) 2713-2999

Renesas Technology Singapore Pte. Ltd.
1 Harbour Front Avenue, #06-10, Keppel Bay Tower, Singapore 098632
Tel: <65> 6213-0200, Fax: <65> 6278-8001

Renesas Technology Korea Co., Ltd.
Kukje Center Bldg. 18th Fl., 191, 2-ka, Hangang-ro, Yongsan-ku, Seoul 140-702, Korea
Tel: <82> (2) 796-3115, Fax: <82> (2) 796-2145

Renesas Technology Malaysia Sdn. Bhd
Unit 906, Block B, Menara Amcorp, Amcorp Trade Centre, No.18, Jalan Persiaran Barat, 46050 Petaling Jaya, Selangor Darul Ehsan, Malaysia
Tel: <603> 7955-9390, Fax: <603> 7955-9510