

GP2D03

Paper Size Sensor System

■ Features

- Paper size sensor system
 - 2-beam paper size sensor **GP2D03** 3pcs.
 - E²PROM for data storage 1pc.
[Serial access type, memory capacity : 128 x 8 bit]
(E²PROM shall be applied to users'.)
- High sensitive detection because of less influence on the color or reflectivity of reflective object thanks to position sensitive detector (PSD)
- 2-beam type (**GP2D03**)
- With initial mode in order to make E²PROM store thresh level for the existence of reflective object

■ Applications

- Copiers

■ Outline Dimensions

(Unit : mm)

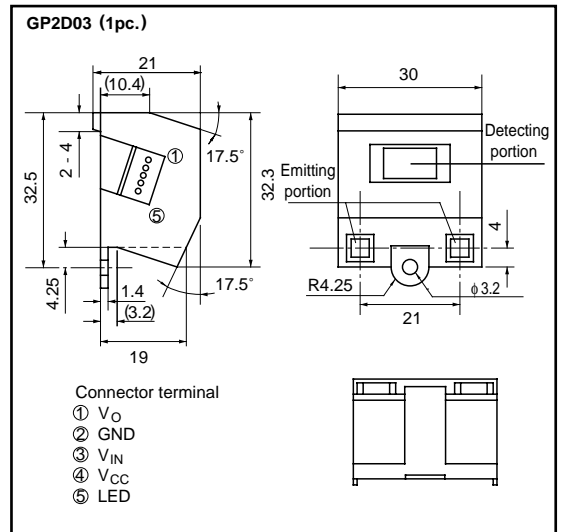

■ Specifications

(Ta = 25°C)

Parameter	Symbol	Rating	Unit
Supply voltage	V _{CC}	5± 0.5	V
*1 Paper detection height	H	TYP. 60	mm
LED beam pitch	L _P	TYP. 21	mm
*2 Approved value of paper position sliding	Δx	MIN. ± 6	mm
*3 Measuring time	t _s	TYP. 140	ms
*4 Paper detection density	OD	0.8 or less	-
Dissipation current	I _{CC}	TYP. 30	mA
Operating temperature	T _{opr}	- 10 to 60	°C

*1 Optional setting in the range of 50mm to 70mm. Between the sensor to setting glass

*2 At 60mm-height

*3 Time requiring for measurement of 6 portions

*4 Reflectivity : 16% or more, OD = log (1/T), T : Reflectivity

■ System Configuration

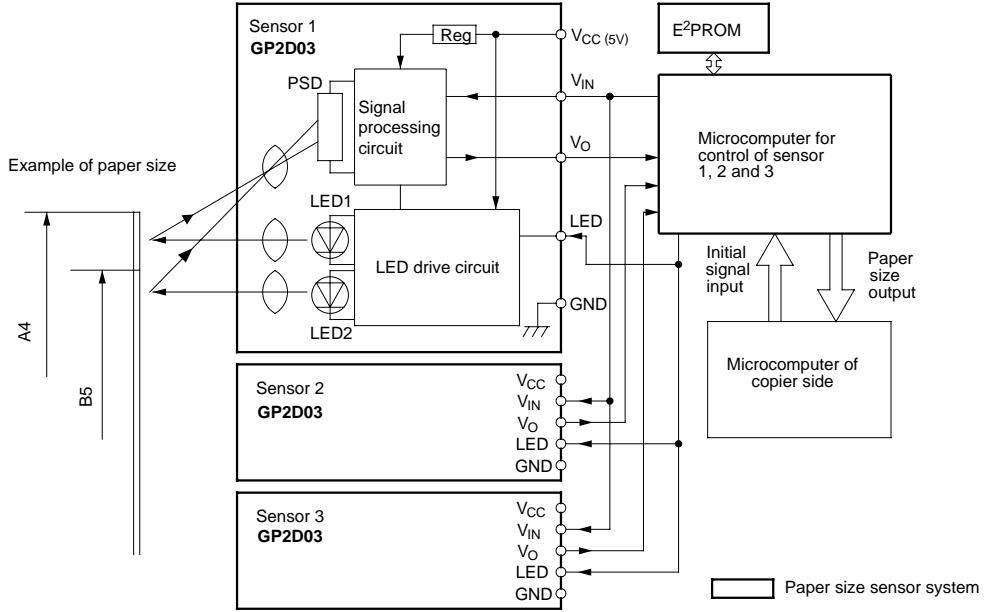

■ Example of Sensor Arrangement

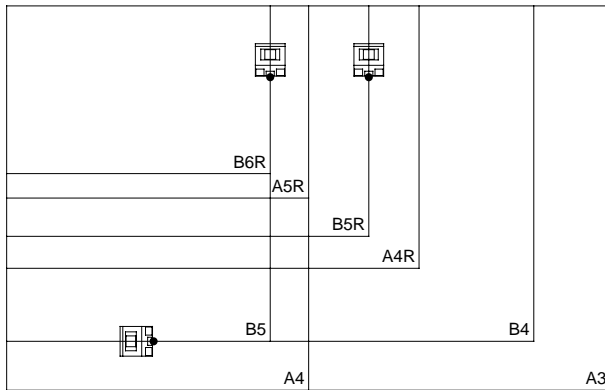

Distance Characteristics of GP2D03

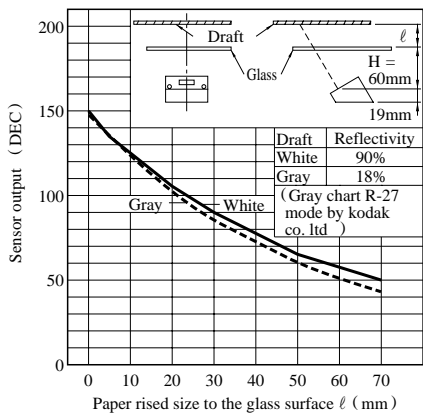

● Please refer to the chapter “Precautions for Use”