

SP4T GaAs Multi-Band GSM Antenna Switch

Features:

- ◆ Available in die form
- ◆ Suitable for multi-band GSM/DCS/PCS/EDGE applications
- ◆ Excellent low control voltage performance
- ◆ Excellent harmonic performance under GSM power levels
- ◆ Very high isolation >31dB typ. at 1.8GHz
- ◆ Very low insertion loss
- ◆ Very low control current

Functional Schematic

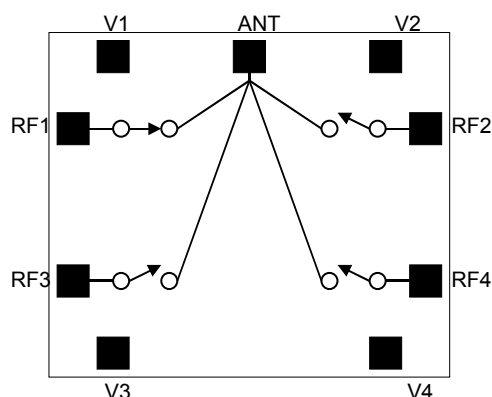

Description and Applications:

The FMS2016 is a low loss, high power and linear single pole four throw Gallium Arsenide antenna switch designed for use in mobile handset applications. The die is fabricated using the Filtronic FL05 0.5 μ m switch process technology which offers leading edge performance optimised for switch applications. The FMS2016 is designed for use in dual, tri and quad – band GSM handset antenna switch modules and RF front-end modules.

Electrical Specifications: (T_{AMBIENT} = 25°C, V_{control} = 0V/2.5V, Z_{IN} = Z_{OUT} = 50 Ω)

Parameter	Test Conditions	Min	Typ	Max	Units
Tx Insertion Loss	0.5 – 1.0 GHz		0.5		dB
	1.0 – 2.0 GHz		0.55		dB
Rx Insertion Loss	0.5 – 1.0 GHz		0.5		dB
	1.0 – 2.0 GHz		0.55		dB
Return Loss	0.5 – 2.5 GHz		32		dB
Isolation	0.5 – 1.0 GHz		34		dB
	1.0 – 2.0 GHz		31		dB
2nd Harmonic Level	1 GHz, Pin = +35 dBm, 100% Duty Cycle		-75		dBc
	2 GHz, Pin = +33 dBm, 100% Duty Cycle		-75		dBc
3rd Harmonic Level	1 GHz, Pin = +35 dBm, 100% Duty Cycle		-75		dBc
	2 GHz, Pin = +33 dBm, 100% Duty Cycle		-75		dBc
Switching speed : Trise, Tfall Ton, Toff	10% to 90% RF and 90% to 10% RF		<0.3		μ s
	50% control to 90% RF and 50% control to 10% RF		<1.0		μ s

Note: External DC blocking capacitors are required on all RF ports (typ: 100pF). All unused ports terminated in 50 Ω .

Truth Table:

V1	V2	V3	V4	PATH (ON)
High	Low	Low	Low	RF1-ANT
Low	High	Low	Low	RF2-ANT
Low	Low	High	Low	RF3-ANT
Low	Low	Low	High	RF4-ANT

Note: 'High' = +2.5V to +5V
 'Low' = 0V to 0.2V

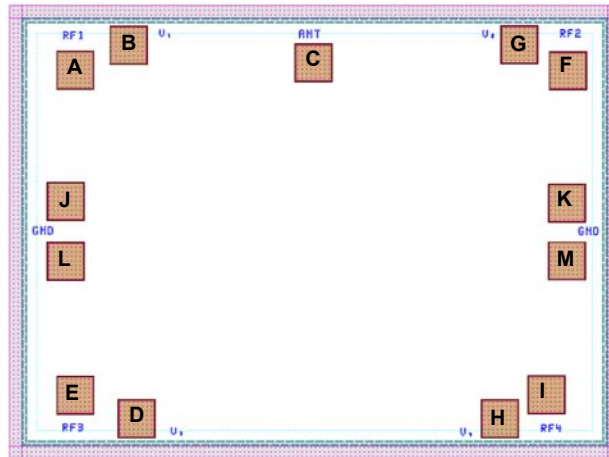
Pad and Die Layout:

Pad	Pad Name	Description	Pin Coordinates
A	RF1	RF input port 1	130, 766
B	V1	DC Control line 1	237, 815
C	ANT	Antenna	613, 783
D	V3	DC Control line 3	256, 84
E	RF3	RF input port 3	136, 128
F	RF2	RF input port 2	1124, 765
G	V2	DC Control line 2	1025, 816
H	V4	DC Control line 4	985, 81
I	RF4	RF input port 4	1080, 130
J	GND1	Ground 1	111, 508
K	GND2	Ground 2	1121, 504
L	GND3	Ground 3	111, 391
M	GND4	Ground 4	1121, 392

Note: Co-ordinates are referenced from the bottom left hand corner of the die to the centre of the bond pad opening.

Die Size (μm)	Die Thickness (μm)	Min. Bond Pad Pitch(μm)	Min. Bond pad opening (μm)
1230 x 900	100	96	70 x 70

Simulated Performance:

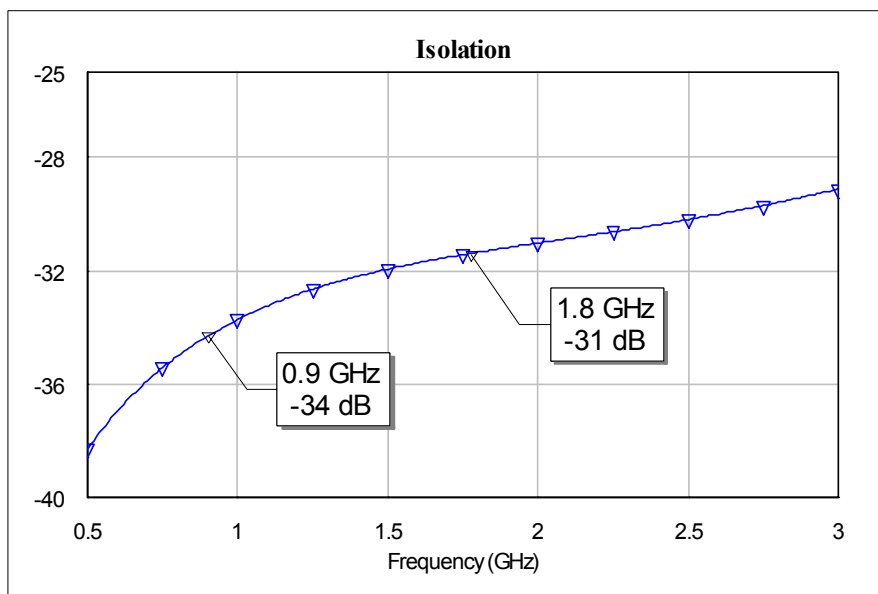
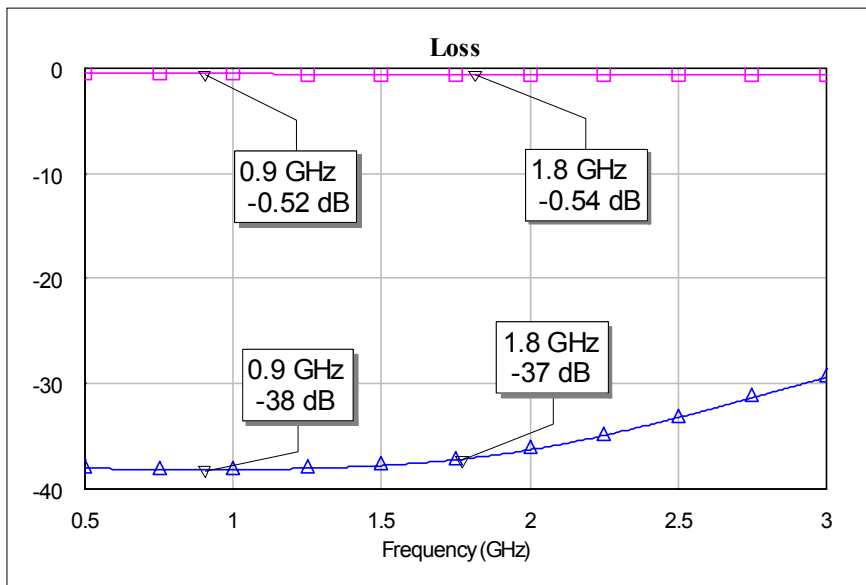

Preferred Assembly Instructions:

GaAs devices are fragile and should be handled with great care. Specially designed collets should be used where possible.

The back of the die is not metallised and the recommended mounting method is by the use of conductive epoxy. Epoxy should be applied to the attachment surface uniformly and sparingly to avoid encroachment of epoxy on to the top face of the die and ideally should not exceed half the chip height. For automated dispense Ablestick LMISR4 is recommended and for manual dispense Ablestick 84-1 LMI or 84-1 LMIT are recommended. These should be cured at a temperature of 150°C for 1 hour in an oven especially set aside for epoxy curing only. If possible the curing oven should be flushed with dry nitrogen.

This part has gold (Au) bond pads requiring the use of gold (99.99% pure) bondwire. It is recommended that 25.4µm diameter gold wire is used. Thermosonic ball bonding is preferred. A nominal stage temperature of 150°C and a bonding force of 40g has been shown to give effective results for 25µm wire. Ultrasonic energy shall be kept to a minimum. For this bonding technique, stage temperature should not be raised above 200°C and bond force should not be raised above 60g. Thermosonic wedge bonding and thermocompression wedge bonding can also be used to achieve good wire bonds.

Bonds should be made from the die first and then to the mounting substrate or package. The physical length of the bondwires should be minimised especially when making RF or ground connections.

Handling Precautions:

To avoid damage to the devices care should be exercised during handling. Proper Electrostatic Discharge (ESD) precautions should be observed at all stages of storage, handling, assembly, and testing. These devices should be treated as Class 1A (0-500 V) as defined in JEDEC Standard No. 22-A114-B. Further information on ESD control measures can be found in MIL-STD-1686 and MIL-HDBK-263.

Disclaimers:

This product is not designed for use in any space based or life sustaining/supporting equipment.