

SURFACE MOUNT SCHOTTKY BARRIER RECTIFIER
VOLTAGE RANGE 20 to 60 Volts CURRENT 3.0 Amperes

FEATURES

- * Fast switching
- * Low switching noise
- * Low forward voltage drop
- * High current capability
- * High switching capability
- * High reliability
- * High surge capability

MECHANICAL DATA

- * Case: Molded plastic
- * Epoxy: Device has UL flammability classification 94V-0
- * Lead: MIL-STD-202E method 208C guaranteed
- * Metallurgically bonded construction
- * Mounting position: Any
- * Weight: 0.098 gram

MAXIMUM RATINGS AND ELECTRICAL CHARACTERISTICS

Ratings at 25 °C ambient temperature unless otherwise specified.
 Single phase, half wave, 60 Hz, resistive or inductive load.
 For capacitive load, derate current by 20%.



DO-214AA

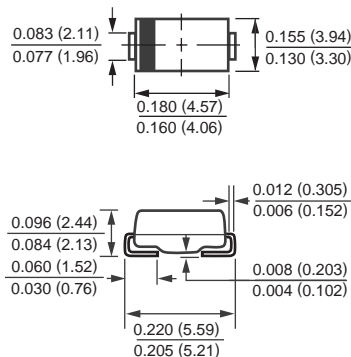

Dimensions in inches and (millimeters)

MAXIMUM RATINGS (At TA = 25°C unless otherwise noted)

RATINGS		SYMBOL	FM320B	FM330B	FM340B	FM350B	FM360B	UNITS
Maximum Recurrent Peak Reverse Voltage		VRRM	20	30	40	50	60	Volts
Maximum RMS Voltage		VRMS	14	21	28	35	42	Volts
Maximum DC Blocking Voltage		VDC	20	30	40	50	60	Volts
Maximum Average Forward Rectified Current at Derating Lead Temperature		IO	3.0					Amps
Peak Forward Surge Current 8.3 ms single half sine-wave superimposed on rated load (JEDEC method)		IFSM	80					Amps
Typical Thermal Resistance (Note 1)		RθJA	25					°C/W
Typical Junction Capacitance (Note 2)		CJ	200					pF
Operating Temperature Range		TJ	-55 to + 125			-55 to + 150		°C
Storage Temperature Range		TSTG	-55 to + 150					°C

ELECTRICAL CHARACTERISTICS (At TA = 25°C unless otherwise noted)

CHARACTERISTICS		SYMBOL	FM320B	FM330B	FM340B	FM350B	FM360B	UNITS
Maximum Instantaneous Forward Voltage at 3.0A DC		VF	.55			.75		Volts
Maximum Average Reverse Current at Rated DC Blocking Voltage	@ TA = 25°C	IR	2.0					mAmps
	@ TA = 100°C		20					mAmps

NOTES : 1. Thermal Resistance (Junction to Ambient): Vertical PC Board Mounting, 0.5" (12.7mm) Lead Length.
 2. Measured at 1 MHz and applied reverse voltage of 4.0 volts.

RATING AND CHARACTERISTIC CURVES (FM320B THRU FM360B)

FIG. 1 - TYPICAL FORWARD CURRENT DERATING CURVE

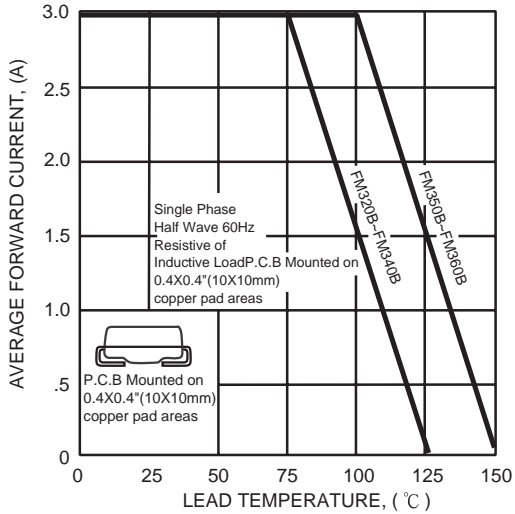

FIG. 2 - TYPICAL REVERSE CHARACTERISTICS

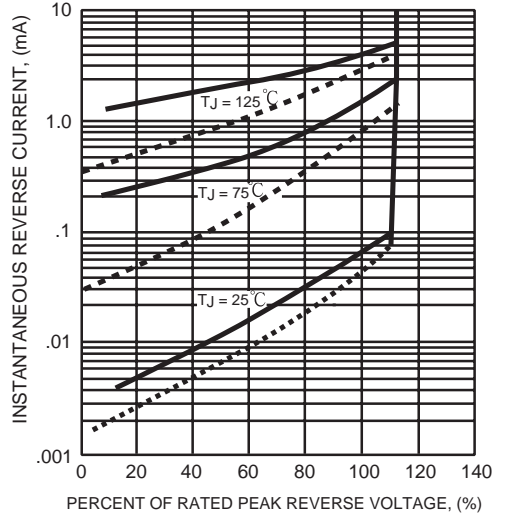

FIG. 3 - TYPICAL INSTANTANEOUS FORWARD CHARACTERISTICS

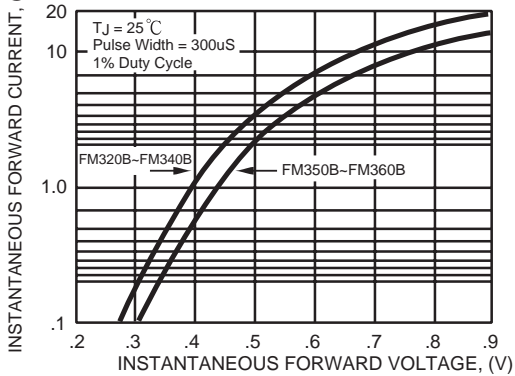

FIG. 4 - TYPICAL JUNCTION CAPACITANCE

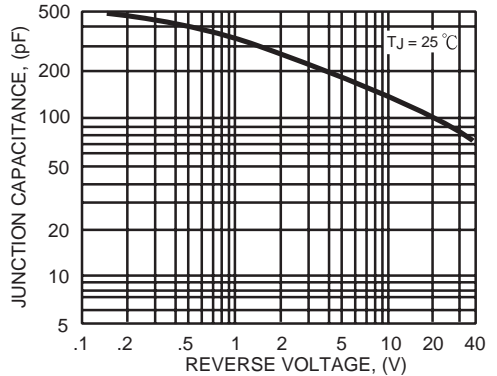
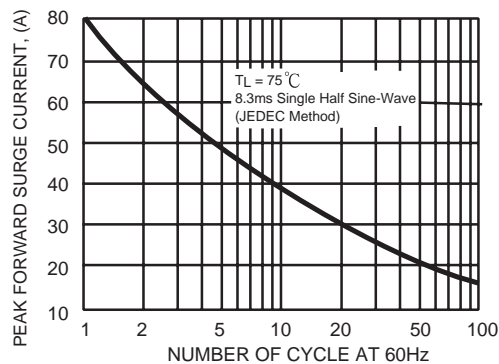
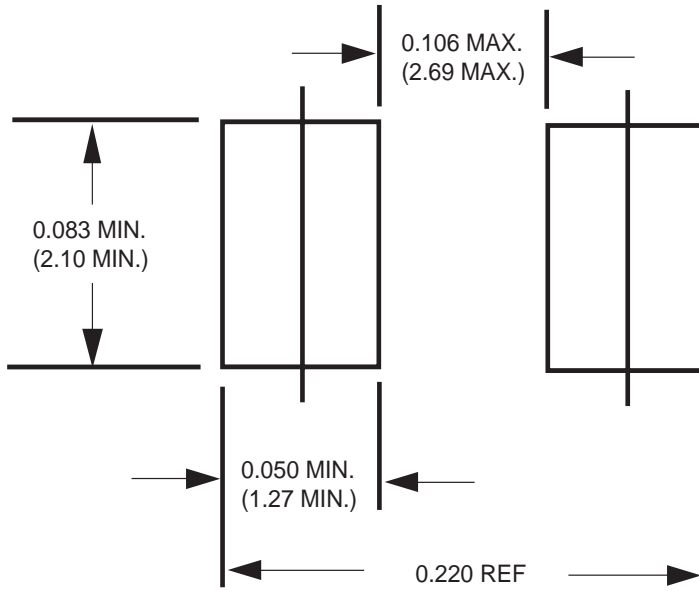

FIG. 5 - MAXIMUM NON-REPETITIVE FORWARD SURGE CURRENT



Mounting Pad Layout



Dimensions in inches and (millimeters)