



義隆電子股份有限公司  
ELAN MICROELECTRONICS CORP.

---

# EM78P915

## 8-BIT MICRO-CONTROLLER

Product  
specification v2.0

ELAN MICROELECTRONICS CORP.  
No. 12, Innovation 1<sup>st</sup> RD., Science-Based Industrial Park  
Hsin Chu City, Taiwan  
TEL: (03) 5639977  
FAX: (03) 5630118

---



## Version History

Specification revision history for EM78P915	
Version	Description
1.1	Add program pin location table
1.2	Pin assignment change, and POR=2.0V, green mode=2.2~5.5V Oscillator start to stable time will smaller/equal 0.5 sec, remove LCD driving Ability control
1.3	Add SDT characteristic table R4 page bit7 (RBF) is modified to Read-only “End of FSK to carrier detect high” is 5 ms Update table 24 Modify R7, IOC7, IOCB, value in table 1
1.4	Add interrupt node, note7 and note8 in page3
1.5	Bug modify in page 21
1.6	Add notice about setting code-option and /POVD on/off in page 3.
1.7	Remove DED function, operation voltage = 3.1V at 10.74MHz
1.8	Modify TDP1/2 description in page 34
1.9	Add chip pad diagram, modify /POVD description
2.0	Add P915/915 family list and development tool list in appendix C, D, E, F

## Relative to Rom-less, OTP and Mask

	OTP	OTP/ROMLess	OTP	Note
	78P911	78P808/78R808	78P915	
Operation voltage	2.5~5.5V(normal mode)	2.2~5.5V(normal mode)	2.2V~5.5V(normal mode)	
Work clock (Max)	3.58MHz	10.74MHz	10.74MHz	
OP	X	Yes	X	
Comparator	CMP1	CMP1, 2, 3	CMP1	
Key tone	X	Yes	X	
External INT	INT0~3	INT0~2	INT0, INT2	
LCD	SEG0~59, COM0~15	SEG0~79 COM0~23	SEG0~27, SEG48~SEG79, COM0~15	
Data Rom	X	256K*8	X	
RAM size	2.5K*8	8K*8	2.5K*8	
Programmable ROM	16K*13	32K*13	32K*13	
SDT	X	X	Yes	
Stack	8	32	8	
Bi-directional port	36	51	44	
DTMF generator	Yes	TONE generator	Current D/A	
DTMF receiver	X	Yes	Yes	
Current D/A	X	Yes	Yes	
MEI/RTF	X	X	X	
Call waiting	Yes	Yes	Yes	
Low battery detect	Yes	Comparator	Comparator	
SPI	X	Yes	Yes	
FSK decode	Yes	Yes	Yes	

\* This specification is subject to be changed without notice.



## User Guide

(Before using this chip, take a look at the following description note, it includes important messages.)

1. You will see some names for the register bits definitions. Some name will be appeared very frequently in the whole spec. The following describes the meaning for the register's definitions such as bit type, bit name, bit number and so on.

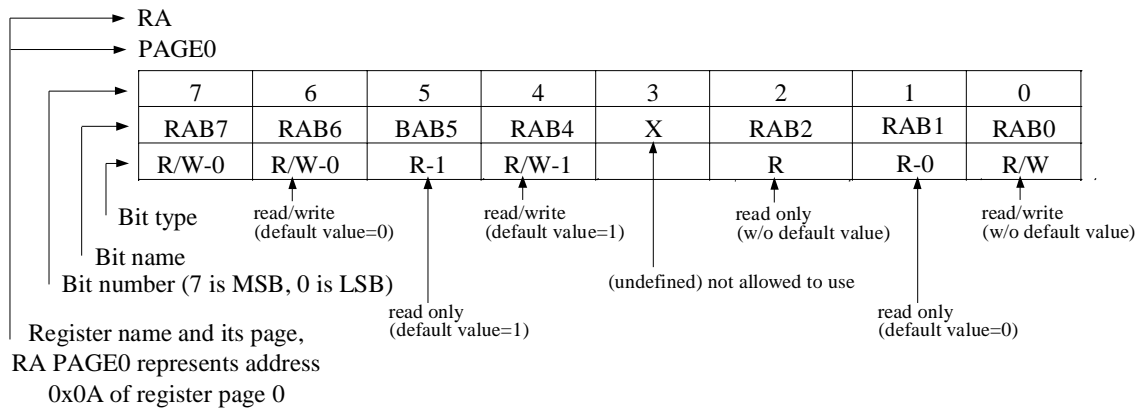

Figure 1, Register overview description

2. There are some undefined bits in the registers. The values in these bits are unpredicted. These bits are not allowed to use. We use the symbol "X" in the spec to recognize them. **A fixed value must be written in some specific unused bits by software or some unpredicted wrong will occur.** These bits are as below.

Register			Default value	Initial Setting value	Effect
Register	PAGE	Bit			
R5	0	7	0	0	Power consumption increase
R6	0	7	0	0	Power consumption increase
R6	1	7~0	00000000	00000000	Un-expect error
R7	0	6~4	000	000	Un-expect error
R7	1	7~0	00000000	00000000	Un-expect error
R8	1	7~0	00000000	00000000	Un-expect error
R9	1	7~0	00000000	00000000	Un-expect error
RE	0	6~5	00	00	Power consumption increase
RE	1	5~4	00	00	Un-expect error
IOC5	0	7	0	0	Power consumption increase
IOC5	1	7~5	000	000	Power consumption increase
IOC5	2	7~0	00000000	00000000	Un-expect error
IOC6	0	7,5~4	0,01	0,01	Un-expect error
IOC6	2	4~3	00	00	Power consumption increase
IOC7	0	6~4	111	111	Un-expect error
IOC7	1	7~0	00000000	00000000	Un-expect error
IOC8	1	7~0	00000000	00000000	Un-expect error
IOCA	1	6~4	111	111	Power consumption increase
IOCB	1	7,5~4	0,01	0,01	Power consumption increase
IOCD	1	7~0	00000000	00000000	Power consumption increase
IOCE	1	1~0	00	00	Power consumption increase
IOCE	1	7~4	000	000	Un-expect error

Table 1, initial setting reference in using ICE915

\* This specification is subject to be changed without notice.



- 3. In the appendix, it provides all operational/special purpose registers, figures and tables list for user to search quickly.
- 4. While switching main clock (regardless of high freq to low freq or on the other hand), adding 6 instructions delay (NOP) is required.
- 5. Please do not switch MCU operation mode from normal mode to sleep mode directly. Before into idle or sleep mode, please switch MCU to green mode.
- 6. For DATA RAM least address (A0~A7), when using “INC” instruction and overflow occur, the middle address will auto\_increase. If using “DEC” instruction and least address from 0x00→0xFF, the middle address can’t auto\_decrease.
- 7. With increasing frequency of using interrupt, it may be occur interrupt flag loss. But it could be solved by our suggestion. So for avoiding any instruction loss, please obey the following program way for now, of course, we already start to enable our production procedure for reducing the possibility of loss.

Suggestion way,

Clear interrupt flag (RF): change “BC” to “MOV”.

Example: clear bit0 of RF,

Before	Suggestion now
BC 0x0f, 0x00	MOV a,@0xFE MOV 0x0f,a

- 8. In the application, some users need latch interrupt flag during disable interrupt mask register (IOCF), but some users don’t need. In the application of EM78 series, we revise this status to latch. So, users must clear the latch interrupt flag before enable interrupt mask register. The method how to use instruction is showed as follows,

Example:

```

IOR   IOCF
MOV  RF,A
MOV  A,@0x??
IOW  IOCF

```

- 9. Code-option setting note: Un-used or empty bit of code-option can’t be changed to 0. So, please keep them in 1 to avoid some un-prediction occur.
- 10. /POVD setting note: please confirm whether /POVD will be enable or disable before ordering EM78P915. If users still couldn’t understand, users can get some information from our FAE or sales.

\* This specification is subject to be changed without notice.



## I. General Description

The EM78P915 is an 8-bit CID (Call Identification) RISC type microprocessor with low power, high speed CMOS technology. Integrated onto a single chip are on chip watchdog (WDT), RAM, ROM, programmable real time clock /counter, internal interrupt, power down mode, LCD driver, FSK decoder, CALL WAITING decoder, SDT detector, current DA module and tri-state I/O. The EM78P915 provides a single chip solution to design a CID of calling message display.

## II. Feature

### CPU

- Operating voltage: 2.2V~5.5V for normal mode

Main CLK (Hz)	Under 0.895M~3.58M	10.74M
Operating Voltage (min)	2.2V	3.1V

- 2.2V~5.5V for green mode
- 32K×13 on chip program ROM
- 2.5K×8 on chip RAM
- Up to 44 bi-directional tri-state I/O ports
- 8 level stack for subroutine nesting
- 8-bit real time clock/counter (TCC)
- Two independent 8 bits up-counter interrupt.
- Selective signal sources and trigger edges , and with overflow interrupt
- Programmable free running on chip watchdog timer
- 99.9% single instruction cycle commands
- 4 step Normal mode CLK : 0.895 , 1.79 , 3.58 , 10.74 MHz generated by internal PLL.
- Four operation modes.
  1. Sleep mode: CPU and PLL turn off, 32.768KHz clock turn off
  2. Idle mode: CPU and PLL turn off, 32.768KHz clock turn on
  3. Green mode: PLL turn off, CPU and 32.768KHz clock turn on
  4. Normal mode: PLL turn on, CPU and 32.768KHz clock turn on
- Universal Low battery detector
- Input port wake up function
- 9 interrupt source, 6 external, 3 internal
- Port key scan function
- Clock frequency 32.768KHz
- oscillator start to stable time will smaller/equal 0.5 sec

### SPI

- Serial Peripheral Interface (SPI) : a kind of serial I/O interface
- Interrupt flag available for the read buffer full or transmitter buffer empty.
- Programmable baud rates of communication
- Three-wire synchronous communication.(shared with IO )

### CID

- Operation Voltage 2.4V~5.5V for FSK
- Operation Voltage 2.4V~5.5V for DTMF receiver
- Compatible with Bellcore GR-30-CORE (formerly as TR-NWT-000030)
- Compatible with British Telecom (BT) SIN227 & SIN242
- FSK demodulator for Bell 202 and ITU-T V.23 (formerly as CCITT V.23)

### CALL WAITING

- Operation Voltage 2.4V~5.5V
- Compatible with Bell-core special report SR-TSV-002476
- Call-Waiting (2130Hz plus 2750Hz) Alert Signal Detector
- Good talk-down and talk-off performance
- Sensitivity compensated by adjusting input OP gain



**LCD**

- LCD operation voltage chosen by software
- Common driver pins : 16
- Segment driver pins : 60
- 1/4 bias
- 1/8,1/16 duty

**Current D/A**

- Operation Voltage 2.2V~5.5V
- 10-bit resolution and 3-bit output level
- Current D/A output can drive speaker through a transistor for sound player
- Can switch output port between DAOUT1 and DAOUT2 by user

**SDT (Stutter Dial Tone)**

- TIA/EIA-855 compatible Stutter Dial Tone detector.
- Detect the dual frequencies (350Hz and 440Hz) of SDT signal.

**PACKAGE**

- None, but only for COB

### III. Application

1. adjunct units
2. answering machines
3. feature phones





COM5	1	102	SEG16
COM4	2	101	SEG17
COM3	3	100	SEG18
COM2	4	99	SEG19
COM1	5	98	SEG20
COM0	6	97	SEG21
NC	7	96	SEG22
NC	8	95	SEG23
NC	9	94	SEG24
NC	10	93	SEG25
NC	11	92	SEG26
NC	12	91	SEG27
NC	13	90	PB0/SEG48
NC	14	89	PB1/SEG49
NC	15	88	PB2/SEG50
VDD	16	87	PB3/SEG51
XIN	17	86	PB4/SEG52
XOUT	18	85	PB5/SEG53
VDD	19	84	PB6/SEG54
PLLC	20	83	PB7/SEG55
RING	21	82	PC0/SEG56
TIP	22	81	PC1/SEG57
EGIN2	23	80	PC2/SEG58
EGIN1	24	79	PC3/SEG59
CWGS	25	78	PC4/SEG60
CWIN	26	77	PC5/SEG61
GND	27	76	PC6/SEG62
GND	28	75	PC7/SEG63
P56/EST	29	74	P80/SEG64
P55/STGT	30	73	P81/SEG65
DAOUT2	31	72	P82/SEG66
NC	32	71	P83/SEG67
NC	33	70	P84/SEG68
NC	34	69	P85/SEG69
NC	35	68	P86/SEG70
NC	36	67	NC
NC	37	66	NC
NC	38	65	NC
	39		P66/DAOUT1
	40		P63/CMP1
	41		P62/SDI
	42		P61/SDO
	43		P60/SCK
	44		TEST
	45		/RESET
	46		P73/INT0
	47		P72/INT0
	48		P71/INT0
	49		P70/INT0
	50		P67/SEG79
	51		P96/SEG78
	52		P95/SEG77
	53		P94/SEG76
	54		P93/SEG75
	55		P92/SEG74
	56		P91/SEG73
	57		NC
	58		NC
	59		NC
	60		NC
	61		NC
	62		NC
	63		NC
	64		NC

Figure 2-2, Pin assignment (for 128 pin QFP)

Package type: EM78P915AQ BD-GR94261 (/POVD disable), EM78P915BQ BD-GR94262 (/POVD enable)

\* This specification is subject to be changed without notice.



V. Functional Block Diagram

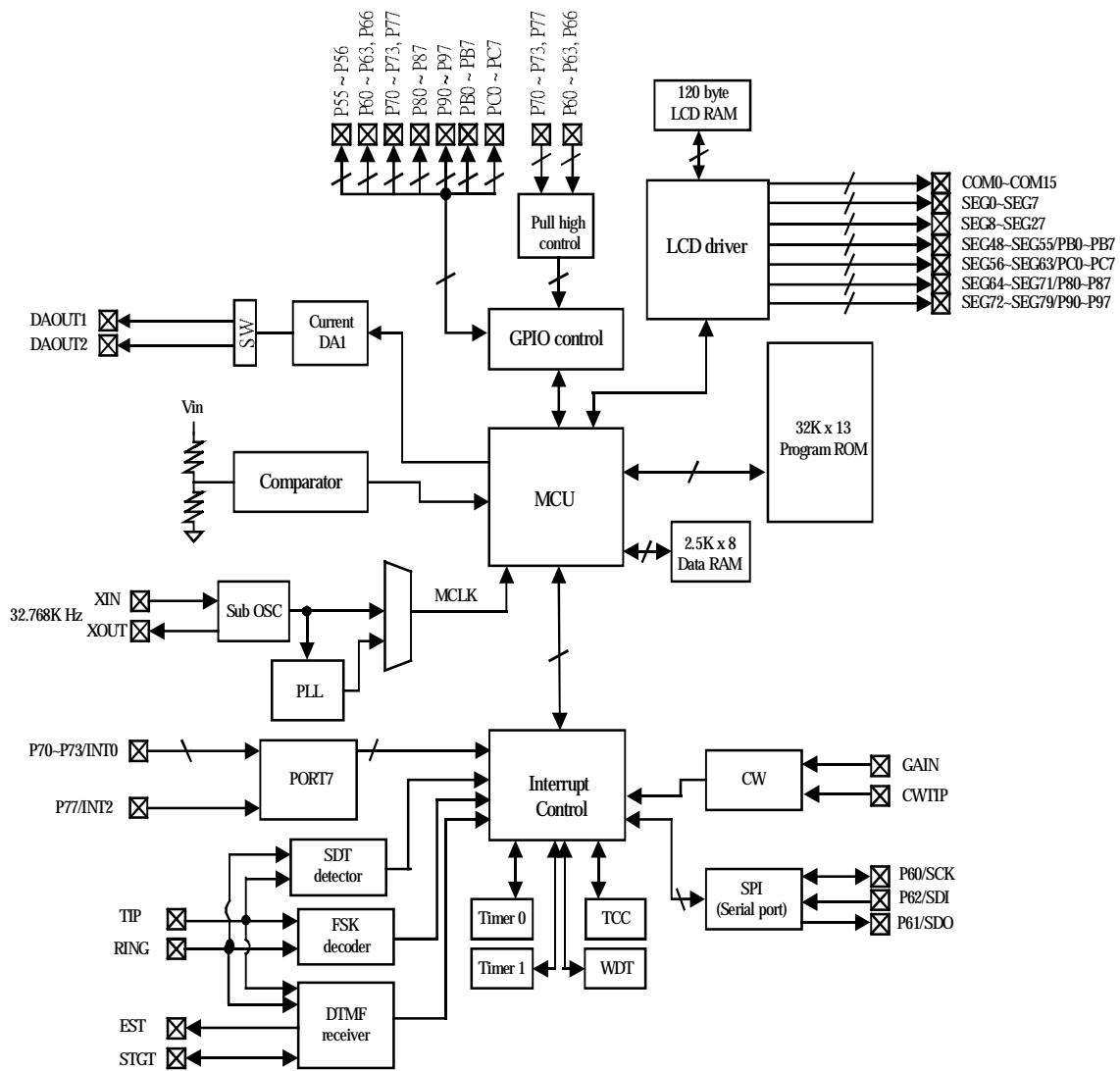

Figure 3, Block diagram1



## VI. Pin Descriptions

PIN	I/O	DESCRIPTION
<b>POWER</b>		
VDD AVDD	POWER	Digital power Analog power They connect together when package as 128 pin QFP.
GND AVSS	POWER	Digital ground Analog ground They connect together when package as 128 pin QFP.
<b>CLOCK</b>		
XIN	I	Input pin for 32.768 kHz oscillator
XOUT	O	Output pin for 32.768 kHz oscillator
PLLC	I	Phase loop lock capacitor, connect a capacitor 0.01u to 0.047u with GND
<b>LCD</b>		
COM0..COM15	O	Common driver pins of LCD drivers
SEG0..SEG7	O	Segment driver pins of LCD drivers
SEG8...SEG27	O	SEG48 to SEG79 are shared with IO PORT.
SEG48..SEG55	O (I/O: PORTB)	
SEG56..SEG63	O (I/O: PORTC)	
SEG64..SEG71	O (I/O: PORT8)	
SEG72..SEG79	O (I/O: PORT9)	
<b>FSK, TONE, KTONE</b>		
TIP	I	Should be connected with TIP side of twisted pair lines for FSK.
RING	I	Should be connected with RING side of twisted pair lines for FSK.
<b>CW</b>		
CWGS	O	Gain adjustment of single-ended input OP Amp
CWIN	I	Single-ended input OP Amp for call waiting decoder
<b>DTMF receiver</b>		
EST	O	Early steering output. Presents a logic high immediately when the digital algorithm detects a recognizable tone-pair (signal condition). Any momentary loss of signal condition will cause EST to return to a logic low. This pin shared with PORT56.
STGT	I/O	Steering input/guard time output (bi-directional). A voltage greater than $V_{tst}$ detected at ST causes the device to register the detected tone-pair and update the output latch. A voltage less than $V_{tst}$ frees the device to accept a new tone-pair. The GT output acts to reset the external steering time-constant; its state is a function of EST and the voltage on ST . This pin shared with PORT55.
<b>SERIAL IO</b>		
SCK	IO (PORT60)	Master: output pin, Slave: input pin. This pin shared with PORT60.
SDO	O (PORT61)	Output pin for serial data transferring. This pin shared with PORT61.
SDI	I (PORT62)	Input pin for receiving data. This pin shared with PORT62.

\* This specification is subject to be changed without notice.



<b>Comparator</b>		
CMP1	I (PORT63)	Comparator input pins. Shared with PORT63.
<b>CURRENT DA</b>		
DAOUT1	O (PORT66)	Current DA output pin. It can be a control signal for sound generating. Shared with PORT66.
DAOUT2	O	Current DA output pin.
<b>IO</b>		
P55 ~ P56	I/O	PORT 5 can be INPUT or OUTPUT port each bit.
P60 ~ P63, P66	I/O	PORT 6 can be INPUT or OUTPUT port each bit. Internal pull high.
P70 ~ P73, P77	I/O	PORT 7 can be INPUT or OUTPUT port each bit. Internal Pull high function. Auto key scan function. Interrupt function.
P80 ~ P87	I/O	PORT 8 can be INPUT or OUTPUT port each bit. Shared with LCD Segment signal.
P90 ~ P97	I/O	PORT 9 can be INPUT or OUTPUT port each bit. Shared with LCD Segment signal.
PB0 ~ PB7	I/O	PORT B can be INPUT or OUTPUT port each bit. Shared with LCD Segment signal.
PC0 ~ PC7	I/O	PORT C can be INPUT or OUTPUT port each bit. Shared with LCD Segment signal.
INT0	PORT70...73	Interrupt sources, which has the same interrupt flag. Any pin from PORT70 to PORT73 has a falling edge signal, it will generate a interruption.
INT2	PORT77	Interrupt source. Once PORT77 has a falling edge or rising edge signal (controlled by CONT register), it will generate a interruption.
TEST	I	Test pin into test mode for factory test only. Connect it ground in application.
/RESET	I	Low reset



## VII. Functional Descriptions

### VII. 1 Operational Registers

Address	R PAGE 0 register	R PAGE 1 register
00	R0	
01	R1 (TCC buffer)	
02	R2 (program counter)	
03	R3 (status )	
04	R4 (RSR, bank select)	R4 (SPI status and control)
05	R5 (port55~56, program ROM page)	R5 (SPI data buffer)
06	R6 (port60~63, 66, /SDT,SDTPWR)	R6 (unused)
07	R7 (port70~73, 77)	R7 (unused)
08	R8 (port80~87)	R8 (unused)
09	R9 (port90~97)	R9 (unused)
0A	RA (CPU mode, clock, FSK, WDT)	RA (LCD RAM address)
0B	RB (portB0~B7)	RB (LCD data buffer)
0C	RC (port C0~C7)	RC (DATA RAM data buffer)
0D	RD (comparator control)	RD (DATA RAM address0~7)
0E	RE (CAS, key scan, LCD control)	RE (DATA RAM address8~11 )
0F	RF (interrupt flag)	

Figure 4, operational registers overview

Address	Control PAGE 0 register	Control PAGE 1 register	Control PAGE 2 register
00			
01			
02			
03			
04			
05	IOC5 (IOC55, 56, P8S,P9S,PBS, PCS,CASPWR)	IOC5 (LCD bias control, CDAS)	IOC5 (Unused)
06	IOC6 (port60~63, 66 IO setting)	IOC6 (current DA)	IOC6 (port s/w, CDAL)
07	IOC7 (port70~73, 77 IO setting)	IOC7 (Unused)	
08	IOC8 (port80~87 IO setting)	IOC8 (Unused)	
09	IOC9 (port90~97 IO setting)	IOC9 (DTMF receiver control)	
0A	IOCA (counter1, 2 prescale and source)	IOCA (port7 pull high)	
0B	IOCB (portB0~B7 IO setting)	IOCB (port6 pull high)	
0C	IOCC (portC0~C7 IO setting)	IOCC (DAoutput2 volume control,DAoutput1/2 switch, DA0~DA2)	
0D	IOCD (counter 1 preset)	IOCD (Unused)	
0E	IOCE (counter 2 preset)	IOCE (comparator IO set)	IOCE (VRSEL)
0F	IOCF (interrupt mask flag)		

Figure 5, Special purpose registers overview

Note1: operational register page0/1 and special purpose register page0/1/2 are different from program page0~31.

Note2: in figure 4, R"X" represents that address "X" of register in the operational register page 0/1.

Note3: in figure 5, IOC"X" represents that address "X" of register in the special purpose register page 0/1/2.

\* This specification is subject to be changed without notice.



Address	
10	general purpose regigter 10
11	general purpose regigter 11
12	general purpose regigter 12
13	general purpose regigter 13
14	general purpose regigter 14
15	general purpose regigter 15
16	general purpose regigter 16
17	general purpose regigter 17
18	general purpose regigter 18
19	general purpose regigter 19
1A	general purpose regigter 1A
1B	general purpose regigter 1B
1C	general purpose regigter 1C
1D	general purpose regigter 1D
1E	general purpose regigter 1E
1F	general purpose regigter 1F

Figure 6, general purpose registers 10 ~ 1F

Address	Bank 0	Bank 1	Bank 2	Bank 3
20	general purpose regigter 20	general purpose regigter 20	general purpose regigter 20	general purpose regigter 20
21	general purpose regigter 21	general purpose regigter 21	general purpose regigter 21	general purpose regigter 21
22	general purpose regigter 22	general purpose regigter 22	general purpose regigter 22	general purpose regigter 22
.	.	.	.	.
.	.	.	.	.
.	.	.	.	.
.	.	.	.	.
3E	general purpose regigter 3E	general purpose regigter 3E	general purpose regigter 3E	general purpose regigter 3E
3F	general purpose regigter 3F	general purpose regigter 3F	general purpose regigter 3F	general purpose regigter 3F

Figure 7, general purpose registers 20 ~ 3F in Bank0/1/2/3

In figure 4 and 5, if user want to read/write one or more of these registers to enable some functions, user must take care of the page number of operational register page and special purpose register page. It must be changed to the proper page number to avoid read/write error occurring.

In figure 6, general purpose registers 10~1F can be read/write anytime without changing operational register pages and special purpose register pages.

In figure 7, general purpose registers 20~3F are the similar to general purpose registers 10~1F, but user must take care of bank0/1/2/3 to avoid read/write error occurring.

\* This specification is subject to be changed without notice.



## VII. 2 Operational Registers Detail descriptions

### R0 (Indirect Addressing Register)

R0 is not a physically implemented register. It is useful as indirect addressing pointer. Any instruction using R0 as register actually accesses data pointed by the RAM Select Register (R4).

Example:

```
MOV a, @ 0x20 ;store a address at R4 for indirect addressing
MOV 0x04,A
MOV a, @ 0xAA ;write data 0xAA to R20 at bank0 through R0
MOV 0x00,A
```

### R1 (TCC)

TCC Data buffer. Increased by 16.38KHz or by the instruction cycle clock (controlled by CONT register). Written and read by the program as any other register.

### R2 (Program Counter)

The structure is depicted in Figure. 6.

Generates  $32K \times 13$  on-chip PROGRAM ROM addresses to the relative programming instruction codes.

"JMP" instruction allows the direct loading of the low 10 program counter bits.

"CALL", this instruction loads the low 10 bits of the PC, PC+1, and then push into the stack.

"RET" ("RETL k", "RETI") instruction loads the program counter with the contents at the top of stack.

"MOV R2, A" allows the loading of an address from the A register to the PC, and the ninth and tenth bits are cleared to "0".

"ADD R2, A" allows a relative address be added to the current PC, and contents of the ninth and tenth bits are cleared to "0".

"TBL" allows a relative address be added to the current PC, and contents of the ninth and tenth bits don't change. The most significant bit (A10~A14) will be loaded with the content of bit PS0~PS3 in the status register (R5) upon the execution of a "JMP", "CALL", "ADD R2, A", or "MOV R2, A" instruction.

If a interrupt trigger, PROGRAM ROM will jump to address8 at page0. The CPU will store ACC, R3 status and R5 PAGE automatically, it will restore after instruction RETI.

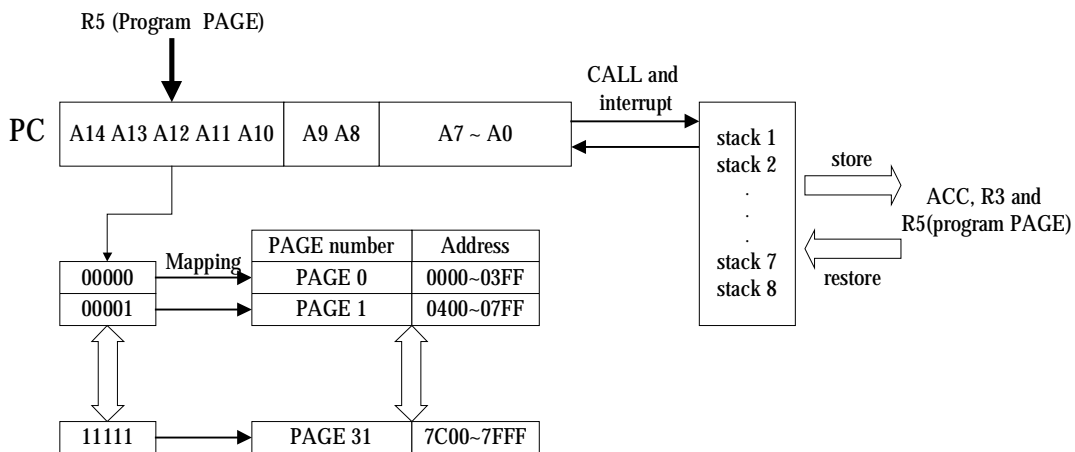

Figure 8, program counter organization

### R3 (Status Register)

#### PAGE 0

7	6	5	4	3	2	1	0
PAGE	IOCP1S	IOCPAGE	T	P	Z	DC	C
R/W-0	R/W-0	R/W-0	R/W-X	R/W-X	R/W-X	R/W-X	R/W-X

\* This specification is subject to be changed without notice.



**Bit 0 (C):** Carry flag

**Bit 1 (DC):** Auxiliary carry flag

**Bit 2 (Z):** Zero flag

**Bit 3 (P):** Power down bit.

Set to 1 during power on or by a "WDTC" command and reset to 0 by a "SLEP" command.

**Bit 4 (T):** Time-out bit.

Set to 1 by the "SLEP" and "WDTC" command, or during power up and reset to 0 by WDT timeout.

EVENT	T	P	REMARK
WDT wake up from sleep mode	0	0	
WDT time out (not sleep mode)	0	1	
/RESET wake up from sleep	1	0	
Power up	1	1	
Low pulse on /RESET	x	x	x : don't care

Table 2, Event for power down bit and timer out bit

**Bit 5(IOCPAGE):** change IOC5 ~ IOCE to another page

Please refer to Fig.4 control register configuration for details.

0/1 → page0 / page1

**Bit 6(IOCP1S):** change IOC PAGE1 and PAGE2 to another option register

Please refer to Fig.4 control register configuration for details.

0/1 → page1 /page2

Bit 6(IOCP1S)	Bit 5 (IOCPAGE)	PAGE SELECT
X	0	PAGE 0
0	1	PAGE 1
1	1	PAGE 2

Table 3, relation with IOCP1S bit and IOCPAGE bit

**Bit 7(PAGE):** change R4 ~ RE to another page

Please refer to Fig.4 control register configuration for details.

0/1 → page0 / page1

#### R4 (RAM selection for common registers R20 ~ R3F, SPI)

##### PAGE 0 (RAM selection register)

7	6	5	4	3	2	1	0
RB1	RB0	RSR5	RSR4	RSR3	RSR2	RSR1	RSR0
R/W-0	R/W-0	R/W-X	R/W-X	R/W-X	R/W-X	R/W-X	R/W-X

**Bit 0 ~ Bit 5 (RSR0 ~ RSR5):** Indirect addressing for common registers R20 ~ R3F

RSR bits are used to select up to 32 registers (R20 to R3F) in the indirect addressing mode.

**Bit 6 ~ Bit 7 (RB0 ~ RB1):** Bank selection bits for common registers R20 ~ R3F

These selection bits are used to determine which bank is activated among the 4 banks for 32 register (R20 to R3F)..

Please refer to Fig.4 control register configuration for details.

##### PAGE 1 (SPI control register)

7	6	5	4	3	2	1	0
RBF	SPIE	SRO	SE	SCES	SBR2	SBR1	SBR0
R-0	R/W-0	R/W-0	R/W-0	R/W-0	R/W-0	R/W-0	R/W-0

Fig. 6 shows how SPI to communicate with other device by SPI module. If SPI is a master controller, it sends clock through the SCK pin. An 8-bit data is transmitted and received at the same time. If SPI, however, is defined as a slave, its SCK pin could be programmed as an input pin. Data will continue to be shifted on a basis of both the clock rate and the selected edge.







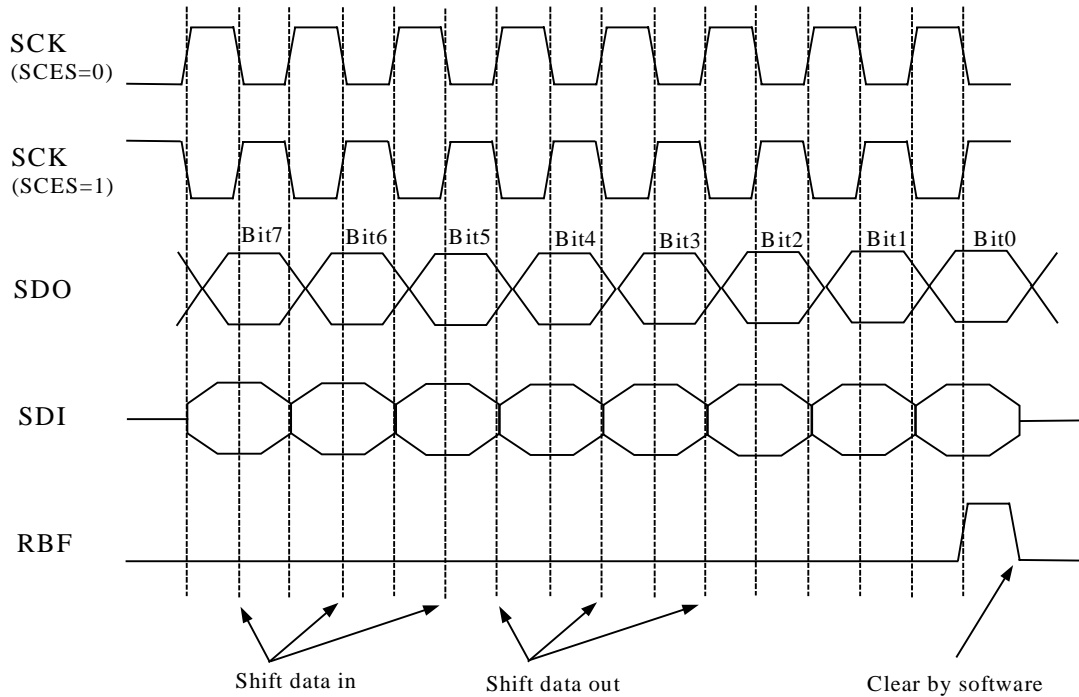

Figure 11, SPI timing

**R5 (PORT5 I/O data, Program page selection, SPI data)**

**PAGE 0 (PORT5 I/O data register, Program page register)**

7	6	5	4	3	2	1	0
X	R56	R55	PS4	PS3	PS2	PS1	PS0
	R/W-0	R/W-0	R/W-0	R/W-0	R/W-0	R/W-0	R/W-0

**Bit 0 ~ Bit 4 (PS0 ~ PS4):** Program page selection bits

PS4	PS3	PS2	PS1	PS0	Program memory page (Address)
0	0	0	0	0	Page 0
0	0	0	0	1	Page 1
0	0	0	1	0	Page 2
0	0	0	1	1	Page 3
:	:	:	:	:	:
:	:	:	:	:	:
1	1	1	1	0	Page 30
1	1	1	1	1	Page 31

Table 5, program page selection

User can use PAGE instruction to change page to maintain program page by user. And the program page is maintained by EMC's compiler. It will change user's program by inserting instructions within program.

**Bit 5 ~ Bit 6 (P55 ~ P56):** 2-bit PORT55~56 I/O data register

User can use IOC5 page0 register to define input or output each bit.

**Bit 7(Unused)**



**PAGE 1 (SPI data buffer)**

7	6	5	4	3	2	1	0
SPIB7	SPIB6	SPIB5	SPIB4	SPIB3	SPIB2	SPIB1	SPIB0
R/W-0	R/W-0	R/W-0	R/W-0	R/W-0	R/W-0	R/W-0	R/W-0

**Bit 0 ~ Bit 7 (SPIB0 ~ SPIB7):** SPI data buffer

If you write data to this register, the data will write to SPIW register. If you read this data, it will read the data from SPIR register. Please refer to figure7

**R6 (PORT6 I/O data)**

**PAGE 0 (PORT6 I/O data register)**

7	6	5	4	3	2	1	0
X	P66	SDTPWR	/SDT	P63	P62	P61	P60
	R/W-0	R/W-0	R	R/W-0	R/W-0	R/W-0	R/W-0

**Bit 0 ~ Bit 3, Bit 6 (P60 ~ P63, P66):** 8-bit PORT60~63, PORT66 I/O data register

User can use IOC6 page0 register to define input or output each bit.

**Bit 4 (/SDT):** Data of /SDT, “0” is expressed the valid signal and “1” is expressed the invalid.

**Bit 5 (SDTPWR):** Control SDT on/off by 1/0.

**Bit 7 (Unused)**

**PAGE 1 (Unused)**

7	6	5	4	3	2	1	0
X	X	X	X	X	X	X	X

**Bit 0 ~ Bit 7 (Unused)**

**R7 (PORT7 I/O data)**

**PAGE 0 (PORT7 I/O data register)**

7	6	5	4	3	2	1	0
P77	X	X	X	P73	P72	P71	P70
R/W-0				R/W-0	R/W-0	R/W-0	R/W-0

**Bit 0 ~ Bit 4, Bit 7(P70 ~ P73, P77):** 8-bit PORT70~74, PORT77 I/O data register

User can use IOC7 page0 register to define input or output each bit.

**Bit 4 ~ 6(Unused)**

**PAGE 1 (Unused)**

7	6	5	4	3	2	1	0
X	X	X	X	X	X	X	X

**Bit 0 ~ Bit 7 (Unused)**

**R8 (PORT8 I/O data)**

**PAGE 0 (PORT8 I/O data register)**

7	6	5	4	3	2	1	0
P87	P86	P85	P84	P83	P82	P81	P80
R/W-0	R/W-0	R/W-0	R/W-0	R/W-0	R/W-0	R/W-0	R/W-0

**Bit 0 ~ Bit 7 (P80 ~ P87):** 8-bit PORT8 ( 0~7 ) I/O data register

User can use IOC8 page0 register to define input or output each bit.

**PAGE 1 (Unused)**

7	6	5	4	3	2	1	0
X	X	X	X	X	X	X	X

**Bit 0 ~ Bit 7 (Unused)**

\* This specification is subject to be changed without notice.



**R9 (PORT9 I/O data)**

**PAGE 0 (PORT9 I/O data register)**

7	6	5	4	3	2	1	0
P97	P96	P95	P94	P93	P92	P91	P90
R/W-0	R/W-0	R/W-0	R/W-0	R/W-0	R/W-0	R/W-0	R/W-0

**Bit 0 ~ Bit 7 (P90 ~ P97):** 8-bit PORT9 (0~7 ) I/O data register

User can use IOC9 page0 register to define input or output each bit.

**PAGE 1 (Unused)**

7	6	5	4	3	2	1	0
X	X	X	X	X	X	X	X

**Bit 0 ~ Bit 7 (Unused)**

**RA (CPU power saving, PLL, Main clock selection, FSK, Watchdog timer, LCD address)**

**PAGE 0 (CPU power saving bit, PLL, Main clock selection bits, FSK, Watchdog timer enable bit)**

7	6	5	4	3	2	1	0
IDLE	PLLEN	CLK1	CLK0	FSKPWR	FSKDATA	/CD	WDTEN
R/W-0	R/W-0	R/W-0	R/W-0	R/W-0	R	R	R/W-0

**Bit 0 (WDTEN):** Watch dog control register

User can use WDTC instruction to clear watch dog counter. The counter 's clock source is 32768/2 Hz. If the prescaler assigns to TCC. Watch dog will time out by  $(1/32768)*2 * 256 = 15.616\text{ms}$ . If the prescaler assigns to WDT, the time of time out will be more times depending on the ratio of prescaler.

0/1 → disable/enable

**Bit 1 (/CD):** FSK carrier detect indication

0/1 → Carrier Valid/CARRIER Invalid

It's a read only signal. If FSK decoder detect the energy of mark or space signal. The Carrier signal will go to low level. Otherwise it will go to high.. Note!! Should be at normal mode.

**Bit 2 (FSKDATA):** FSK decoding data output

It's a read only signal. If FSK decode the mark or space signal , it will output high level signal or low level signal at this register. It's a raw data type. That means the decoder just decode the signal and has no process on FSK signal. Note!! Should be at normal mode.

User can use FSK data falling edge interrupt function to help data decoding.

Ex:

```
MOV A,@01000000
```

```
IOW IOCF ;enable FSK interrupt function
```

```
CLR RF
```

```
ENI ;wait for FSK data's falling edge
```

:

0 = Space data ( 2200Hz )

1 = Mark data (1200Hz)

**Bit 3 (FSKPWR):** FSK power control

0/1 → FSK decoder powered down / FSK decoder powered up

It's the control register of FSK block power.

The relation between bit 1 to bit 3 is shown in Figure.10. You have to power FSK decoder up first, then wait a setup time (Tsup) and check carrier signal (/CD). If the carrier is low, program can process the FSK data.

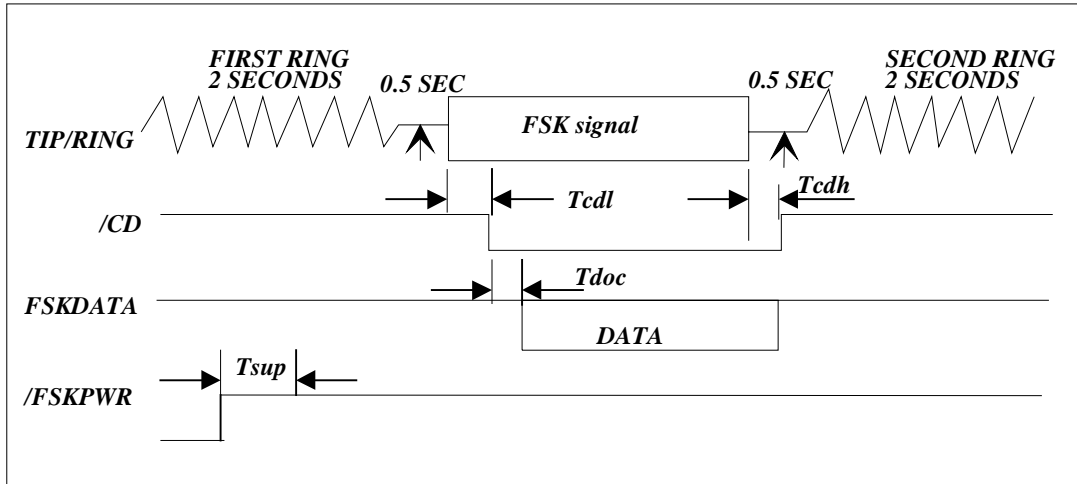

Figure 12, the relation between bit 1 ~ bit 3 of FSK in RA

The controller is a CMOS device designed to support the Caller Number Deliver feature which is offered by the Regional Bell Operating Companies. The FSK block comprises one path: the signal path. The signal path consist of an input differential buffer, a band pass filter, an FSK demodulator and a data valid with carrier detect circuit.

In a typical application, user can use his own external ring detect output as a triggering input to IO port. User can use this signal to wake up whole chip by external ring detect signal.

By setting "1" to bit 3 (FSKPWR) of register RA to activate the block of FSK decoder. If bit 3 (FSKPWR) of register RA is set to "0", the block of FSK decoder will be powered down.

The input buffer accepts a differential AC coupled input signal through the TIP and RING input and feeds this signal to a band pass filter. Once the signal is filtered, the FSK demodulator decodes the information and sends it to a post filter. The output data is then made available at bit 2 (FSKDATA) of register RA. This data, as sent by the central office, includes the header information (alternate "1" and "0") and 150 ms of marking which precedes the date, time and calling number. If no data is present, the bit 2 (DATA) of register RA is held on "1" state. This is accomplished by an carrier detect circuit which determines if the in-band energy is high enough. If the incoming signal is valid, bit 1 (/CD) of register RA will be "0" otherwise it will be held on "1". And thus the demodulated data is transferred to bit 2 (DATA) of register RA. If it is not, then the FSK demodulator is blocked.

#### Bit 4 ~ Bit 5 (CLK0 ~ CLK1): Main clock selection bits

User can choose different frequency of main clock by CLK1 and CLK2. All the clock selection is list below.

PLLEN	CLK1	CLK0	Sub clock	MAIN clock	CPU clock
1	0	0	32.768kHz	895.658kHz	895.658kHz (Normal mode)
1	0	1	32.768kHz	1.7913MHz	1.7913MHz (Normal mode)
1	1	0	32.768kHz	10.7479MHz	10.7479MHz (Normal mode)
1	1	1	32.768kHz	3.5826MHz	3.5826MHz (Normal mode)
0	Don't care	don't care	32.768kHz	Don't care	32.768kHz (Green mode)
0	Don't care	don't care	32.768kHz	Don't care	32.768kHz (Green mode)
0	Don't care	don't care	32.768kHz	Don't care	32.768kHz (Green mode)
0	Don't care	don't care	32.768kHz	Don't care	32.768kHz (Green mode)

Table 6, main clock selection

#### Bit 6 (PLLEN): PLL enable control bit

It is CPU mode control register. If PLL is enabled, CPU will operate at normal mode (high frequency, main clock); otherwise, it will run at green mode (low frequency, 32768 Hz).

0/1 → disable/enable

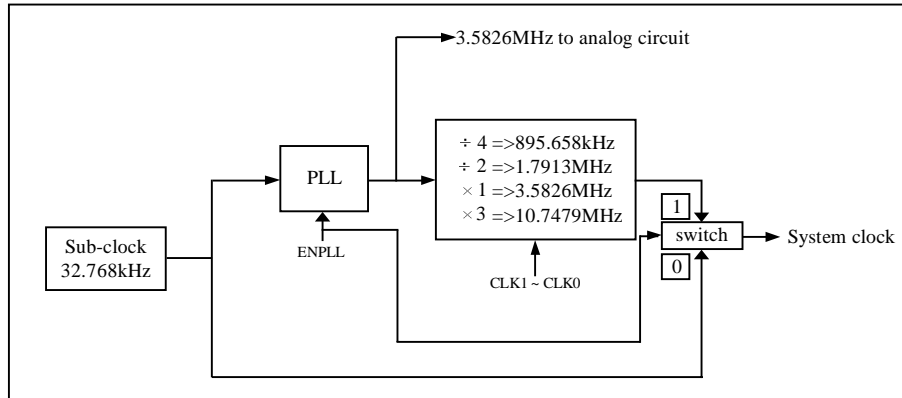

Figure 13, the relation between 32.768kHz and PLL

**Bit 7 (IDLE): power saving mode control register**

When PLL is disable, users can set this bit after using "SLEP" instruction for SLEEP mode or IDLE mode selection.

0/1 -> SLEEP/IDLE

this bit will decide SLEP instruction which to go.

The status after wake-up and the wake-up sources list as the table below.

Wakeup signal	SLEEP mode RA(7,6)=(0,0) + SLEP	IDLE mode RA(7,6)=(1,0) + SLEP	GREEN mode RA(7,6)=(x,0) no SLEP	NORMAL mode RA(7,6)=(x,1) no SLEP
TCC time out IOCF bit 0=1 And "ENI"	No function	(1) wake-up (2) interrupt (jump to address 8 at page 0) (3) after RETI instruction, jump to SLEP next instruction	Interrupt (jump to address 8 at page0)	Interrupt (jump to address 8 at page0)
COUNTER1 time out IOCF bit 1=1 And "ENI"	No function	(1) wake-up (2) interrupt (jump to address 8 at page 0) (3) after RETI instruction, jump to SLEP next instruction	Interrupt (jump to address 8 at page0)	Interrupt (jump to address 8 at page0)
COUNTER2 time out IOCF bit 2=1 And "ENI"	No function	(1) wake-up (2) interrupt (jump to address 8 at page 0) (3) after RETI instruction, jump to SLEP next instruction	Interrupt (jump to address 8 at page0)	Interrupt (jump to address 8 at page0)
WDT time out	RESET and Jump to address 0	(1) wake-up (2) next instruction	RESET and Jump to address 0	RESET and Jump to address 0



PORT7 IOCF bit3 or bit5 = 1 And "ENI"	RESET and Jump to address 0	(1) wake-up (2) interrupt (jump to address 8 at page 0) (3) after RETI instruction, jump to SLEP next instruction	Interrupt (jump to address 8 at page0)	Interrupt (jump to address 8 at page0)
---	-----------------------------------	--	--	--

Table 7, sleep/green/normal modes with wake up signal

<Note> Stack overflow interrupt function is exist in ROM less and OTP chip only.

<Note> PORT70 ~ PORT73 's wakeup function is controlled by IOCF bit3 and ENI instruction. They are falling edge trigger.

PORT77 's wakeup function is controlled by IOCF bit5 and ENI instruction. It's falling edge or rising edge trigger (controlled by CONT register).

**PAGE 1 (LCD address)**

7	6	5	4	3	2	1	0
LCDA7	LCDA6	LCDA5	LCDA 4	LCDA 3	LCDA 2	LCDA 1	LCDA 0
R/W-0	R/W-0	R/W-0	R/W-0	R/W-0	R/W-0	R/W-0	R/W-0

**Bit 0 ~ Bit 7 (LCDA0 ~ LCDA7):** LCD address for LCD RAM reading or writing

The data in the LCD RAM correspond to the COMMON and SEGMENT signals as the table.

COM15 ~COM8 (set R9 PAGE1 bit7=0)	COM7 ~ COM0 (set R9 PAGE1 bit7=0)	
Address 80H	Address 00H	SEG0
Address 81H	Address 01H	SEG1
Address 82H	Address 02H	SEG2
:	:	:
Address 9BH	Address 1BH	SEG27
Address 9CH	Address 1CH	Empty
:	:	:
Address AFH	Address 2FH	Empty
Address B0H	Address 30H	SEG48
:	:	:
Address CEH	Address 4EH	SEG78
Address CFH	Address 4FH	SEG79
Address D0H	Address 50H	Empty
:	:	:
Address FFH	Address 7FH	Empty

Table 8, Common/Segment signal

**RB (PORTB I/O data, LCD data)**

**PAGE 0 (PORTB I/O data register)**

7	6	5	4	3	2	1	0
PB7	PB6	PB5	PB4	PB3	PB2	PB1	PB0
R/W-0	R/W-0	R/W-0	R/W-0	R/W-0	R/W-0	R/W-0	R/W-0

**Bit 0 ~ Bit 7 (PB0 ~ PB7):** 8-bit PORTB0~B7 I/O data register

User can use IOCB page0 register to define input or output each bit.

\* This specification is subject to be changed without notice.



**PAGE 1 (LCD data buffer)**

7	6	5	4	3	2	1	0
LCDD7	LCDD6	LCDD5	LCDD4	LCDD3	LCDD2	LCDD1	LCDD0
R/W-0	R/W-0	R/W-0	R/W-0	R/W-0	R/W-0	R/W-0	R/W-0

**Bit 0 ~ Bit 7 (LCDD0 ~ LCDD7):** LCD data buffer for LCD RAM reading or writing

Example.

```
MOV A, @0
MOV R9_PAGE1, A
MOV RA_PAGE1, A ;ADDRESS
MOV A, @0XAA
MOV RB_PAGE1, A ;WRITE DATA 0XAA TO LCD RAM
MOV A, RB_PAGE1 ;READ DATA FROM LCD RAM
```

**RC (PORTC I/O data, Data RAM data)**

**PAGE 0 (PORTC I/O data register)**

7	6	5	4	3	2	1	0
PC7	PC6	PC5	PC4	PC3	PC2	PC1	PC0
R/W-0	R/W-0	R/W-0	R/W-0	R/W-0	R/W-0	R/W-0	R/W-0

**Bit 0 ~ Bit 7 (PC0 ~ PC7):** 8-bit PORTC0~C7 I/O data register

User can use IOCC page0 register to define input or output each bit.

**PAGE 1 (Data RAM data buffer)**

7	6	5	4	3	2	1	0
RAMD7	RAMD6	RAMD5	RAMD4	RAMD3	RAMD2	RAMD1	RAMD0
R/W-0	R/W-0	R/W-0	R/W-0	R/W-0	R/W-0	R/W-0	R/W-0

**Bit 0 ~ Bit 7 (RAMD0 ~ RAMD7):** Data RAM data buffer for RAM reading or writing.

Example.

```
MOV A, @1
MOV RD_PAGE1, A
MOV A, @0
MOV RE_PAGE1, A
MOV A, @0x55
MOV RC_PAGE1, A ;write data 0x55 to DATA RAM which address is "0001".
MOV A, RC_PAGE1 ;read data
```

**RD (Comparator control, Data RAM address (0 ~ 7))**

**PAGE 0 (Comparator control bits)**

7	6	5	4	3	2	1	0
CMPEN	CMPFLAG	CMPS1	CMPS0	CMP_B3	CMP_B2	CMP_B1	CMP_B0
R/W-0	R	R-0	R-0	R/W-0	R/W-0	R/W-0	R/W-0

If user define the PORT63 (by COMPIN1 at IOCE page1) to a comparator input. User can use this register to control comparator's function.

**Bit 0~Bit 3(CMP\_B0~CMP\_B3):** Reference voltage selection of internal bias circuit for comparator.

$$\text{Reference voltage for comparator} = VDD \times \frac{n + 0.5}{16}, \text{ for } n = 0 \sim 15$$

**Bit 4~Bit 5(CMPS0~CMPS1):** Channel selection to CMP1

CMPS1	CMPS0	Input
0	0	CMP1

Table 9, channel selection of CMP

**Bit 6(CMPFLAG):** Comparator output flag

0 → Input voltage < reference voltage

\* This specification is subject to be changed without notice.



1 → Input voltage > reference voltage

**Bit 7(CMPEN):** Enable control bit of comparator.

0/1 → disable/enable, when this bit is set to “0”, 2.0V ref circuit is also powered off.

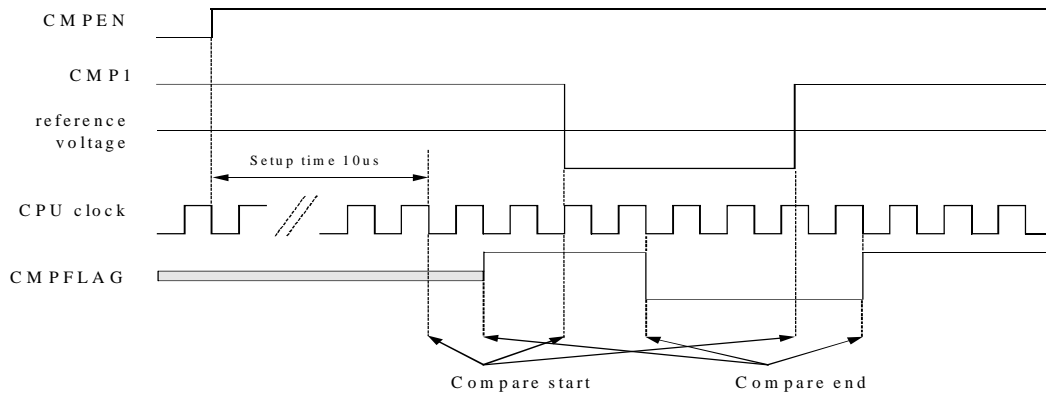

Figure 14, Comparator timing

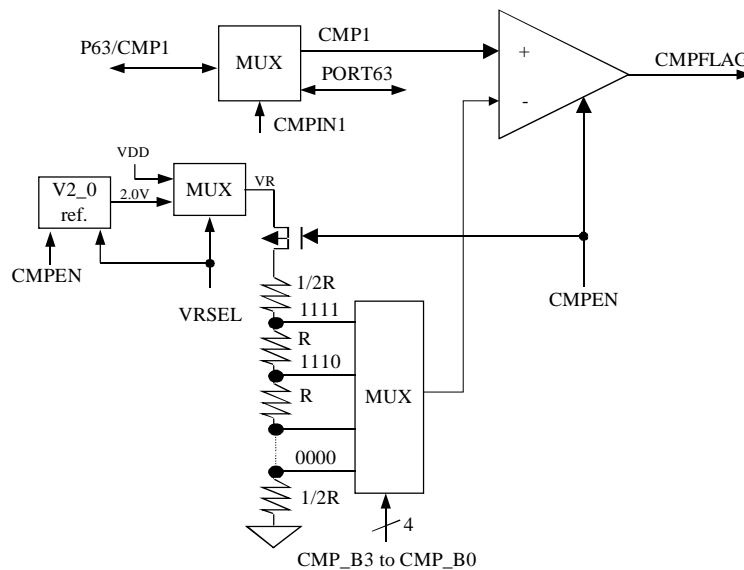

Figure 15, Comparator circuit

If users want to enable/disable 2.0V to be reference voltage, please refer to bit7 (VRSEL) of IOCE page 2.

**PAGE 1 (Data RAM address0 ~ address7)**

7	6	5	4	3	2	1	0
RAMA7	RAMA6	RAMA5	RAMA4	RAMA3	RAMA2	RAMA1	RAMA0
R/W-0	R/W-0	R/W-0	R/W-0	R/W-0	R/W-0	R/W-0	R/W-0

**Bit 0~Bit 7(RAMA0~RAMA7):** Data RAM address (address0 to address7) for RAM reading or writing

*Note: if users read address, which out the range (2.5K), the data maybe a random value or previous data.*

\* This specification is subject to be changed without notice.



**RE (CAS, Key scan, LCD control, Data RAM address (8 ~ 11))**

**PAGE 0 (Key scan control, LCD control)**

7	6	5	4	3	2	1	0
CAS	X	X	KEYSCAN	LCD1	LCD0	LCDM1	LCDM0
R			R/W-0	R/W-0	R/W-0	R/W-0	R-0

**Bit 0~Bit 1(LCDM0~LCDM1):** LCD common mode, bias select and COM/SEG switch control bits

LCDM1, LCDM0	COM output mode	LCD bias	COM/SEG switch
0,0	16 common	1/4 bias	SEG0 ~ SEG7 select
0,1	Unused		
1,0	8 common	1/4 bias	SEG0 ~ SEG7 select
1,1	Unused		

Table 10, LCD common mode

<Note> When 8 and 16 LCD common mode is set, SEG0 ~ SEG7 and LCD bias is 1/4 bias.

**Bit 2~Bit 3 (LCD0~LCD1):** LCD operation function definition.

LCD1, LCD0	LCD operation
0,0	Disable
0,1	Blanking
1,0	Reserved
1,1	LCD enable

Table 11, LCD operation function define

The controller can drive LCD directly. LCD block is made up of LCD driver, display RAM, segment output pins, common output pins and LCD operating bias pins.

Duty, the number of segment, the number of common and frame frequency are determined by LCD mode register RE PAGE0 Bit 0~ Bit 1.

The basic structure contains a timing control, which uses the basic frequency 32.768kHz to generate the proper timing for different duty and display access. RE PAGE1 register is a command register for LCD driver and display. The LCD display (disable, enable, blanking) is controlled by RE PAGE0 Bit 2 ~ Bit 3 and the driving duty is decided by RE PAGE Bit 0 ~ Bit 2. LCD display data is stored in data RAM which address and data access controlled by registers RA PAGE1 and RB PAGE1.

User can regulate the contrast of LCD display by IOC5 PAGE1 (BIAS3..BIAS0). Up to 16 levels contrast is convenient for better display. And the internal voltage follower can afford large driving source.

**COM signal:** The number of COM pins varies according to the duty cycle used, as following:

In 1/8 duty mode COM8 ~ COM15 must be open.

In 1/16 duty mode COM0 ~ COM15 pins must be used.

Duty	COM0 ~ COM7	COM8	COM9	..	COM15
1/8	o	x	x	..	x
1/16	o	o	o	..	o

x : open, o : select

Table 12, relation with Duty mode and COM

**SEG signal:** The segment signal pins are connected to the corresponding display RAM. The high byte to the low byte Bit 0 ~ Bit 7 are correlated to COM0 ~ COM15 respectively. When a bit of display RAM is 1, a select signal is sent to the corresponding segment pin, and when the bit is 0, a non-select signal is sent to the corresponding segment pin.

\* This specification is subject to be changed without notice.

**Bit 4(KEYSCAN):** Key scan function enable control bit

0/1 → disable/enable

If you enable key scan function LCD waveform will has a small pulse within a period like Fig.14.

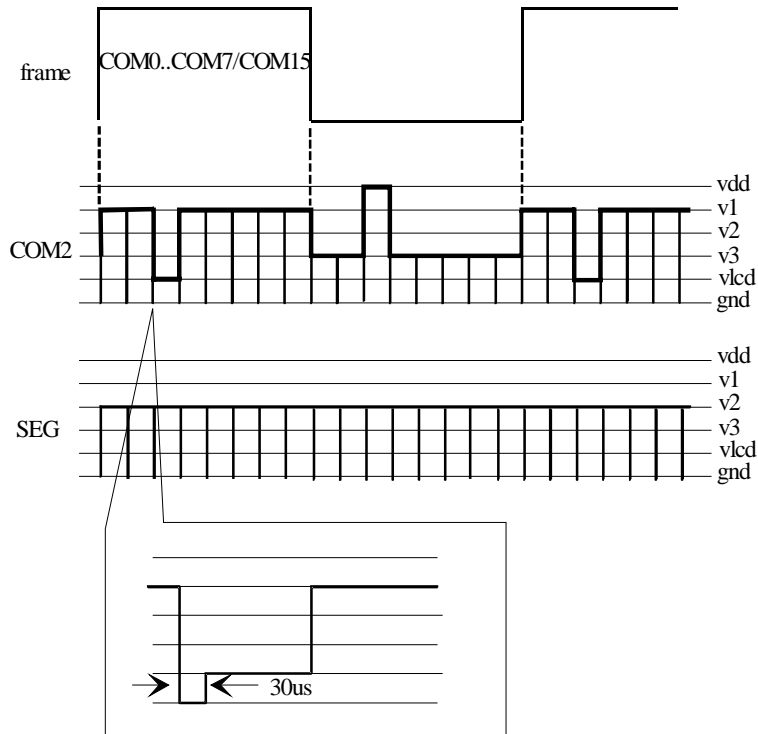

Figure 16, key scan waveform for 1/8, 1/16 duty

**Bit 5(Unused)**

**Bit 6(Unused)**

RELATION BETWEEN SEG , KEYSKAN

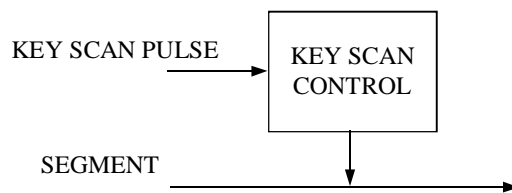

Figure 17, KEYSKAN and segments

**Bit 7(CAS):** CALL WAITING decoding output

0/1 → CW data valid / No data



Software design flow:

- Step1: Port70 ~ port73 set to input mode
- Step2: Port70~port73 pull high
- Step3: Enable key scan signal
- Step4: Once push a key. Set RA bit6 = "1" and switch to normal mode
- Step5: Blank LCD. Disable scan key signal
- Step6: Set portX as normal i/o. PortX sent probe signal to port70~73 and read port70~73. Get the key.  
*Note: a probe signal should be delay a instruction at least to another probe signal*
- Step7: Set portX to SEG port, enable LCD.

*Note: one port must be port70~73 (INT0), and another port is the shared port like port9, port8, portC and portB.*

**PAGE 1 (Data RAM address8 ~ address11)**

7	6	5	4	3	2	1	0
X	X	X	X	RAMA11	RAMA10	RAMA9	RAMA8
				R/W-0	R/W-0	R/W-0	R/W-0

**Bit 0~Bit 4(RAMA8~RAMA11)** : Data RAM address (address8 to address11) for RAM reading.

**Bit 6 (Unused)**

**Bit 7 (Unused)**

**RF (Interrupt flags)**

7	6	5	4	3	2	1	0
RBF/SDT	FSK/CW	INT2	SDTI	INT0	CNT2	CNT1	TCIF
R/W-0	R/W-0	R/W-0	R/W-0	R/W-0	R/W-0	R/W-0	R/W-0

"1" means interrupt request, "0" means non-interrupt

**Bit 0(TCIF)**: TCC timer overflow interrupt flag

Set when TCC timer overflows.

**Bit 1(CNT1)**: Counter1 timer overflow interrupt flag

Set when counter1 timer overflows.

**Bit 2(CNT2)**: Counter2 timer overflow interrupt flag

Set when counter2 timer overflows.

**Bit 3(INT0)**: External INT0 pin interrupt flag

If PORT70, PORT7, PORT72 or PORT73 has a falling edge trigger signal. CPU will set this bit.

**Bit 4(SDTI)**: SDT interrupt flag

Set when receive a SDT valid data.

**Bit 5(INT2)**: External INT2 pin interrupt flag

If PORT77 has a falling edge or rising edge (controlled by CONT register) trigger signal. CPU will set this bit.

**Bit 6(FSK/CW)**: FSK data or Call waiting data interrupt flag.

If FSKDATA or CAS has a falling edge trigger signal, CPU will set this bit.

**Bit 7(RBF/STD)**: SPI data transfer complete or DTMF receiver signal valid interrupt

If serial IO 's RBF signal has a rising edge signal (RBF set to "1" when transfer data completely), CPU will set this bit.

Or DTMF receiver's STD signal has a rising edge signal (DTMF decode a DTMF signal).

IOCF is the interrupt mask register. User can read and clear.

Trigger edge as the table



---

Signal	Trigger	<Note>
TCC	Time out	
COUNTER1	Time out	
COUNTER2	Time out	
INT0	Falling edge	
SDTI	SDT valid data	
INT2	Falling/Falling & rising edge	Controlled by CONT register
FSK	Falling edge	
RBF/STD	Rising edge	

Table 13, interrupt trigger



**R10~R3F (General Purpose Register)**

**R10~R3F (Banks 0 ~ 3):** All of them are general purpose registers.

**VII. 2 Special Purpose Registers**

**A (Accumulator)**

Internal data transfer, or instruction operand holding  
It's not an addressable register.

**CONT (Control Register)**

7	6	5	4	3	2	1	0
INT_EDGE	INT	TS	X	PAB	PSR2	PSR1	PSR0
R/W-1	R/W-1	R/W-1	R/W-1	R/W-1	R/W-1	R/W-1	R/W-1

**Bit 0~Bit 2(PSR0~PSR2):** TCC/WDT prescaler bits

PSR2	PSR1	PSR0	TCC rate	WDT rate
0	0	0	1:2	1:1
0	0	1	1:4	1:2
0	1	0	1:8	1:4
0	1	1	1:16	1:8
1	0	0	1:32	1:16
1	0	1	1:64	1:32
1	1	0	1:128	1:64
1	1	1	1:256	1:128

Table 14, pre-scale of TCC and WDT

**Bit 3(PAB):** Prescaler assignment bit

0/1 → TCC/WDT

**Bit 4:** undefined

**Bit 5(TS):** TCC signal source

0 → Instruction clock

1 → 16.384kHz

Instruction clock = MCU clock/2, Refer to RA Bit 4 ~ Bit 6 for PLL and Main clock selection. See fig.17.

**Bit 6(INT):** INT enable flag

0 → interrupt masked by DISI or hardware interrupt

1 → interrupt enabled by ENI/RETI instructions

**Bit 7(INT\_EDGE):** interrupt edge type of P77

0 → P77's interruption source is a rising edge signal and falling edge signal.

1 → P77's interruption source is a falling edge signal.

CONT register is readable (CONTR) and writable (CONTW).

**TCC and WDT:**

There is an 8-bit counter available as prescaler for the TCC or WDT. The prescaler is available for the TCC only or WDT only at the same time.

An 8 bits counter is available for TCC or WDT determined by the status of the bit 3 (PAB) of the CONT register.

See the prescaler ratio in CONT register.

Fig.16 depicts the circuit diagram of TCC/WDT.

Both TCC and prescaler will be cleared by instructions which write to TCC each time.

The prescaler will be cleared by the WDTC and SLEP instructions, when assigned to WDT mode.

The prescaler will not be cleared by SLEP instructions, when assigned to TCC mode.

\* This specification is subject to be changed without notice.

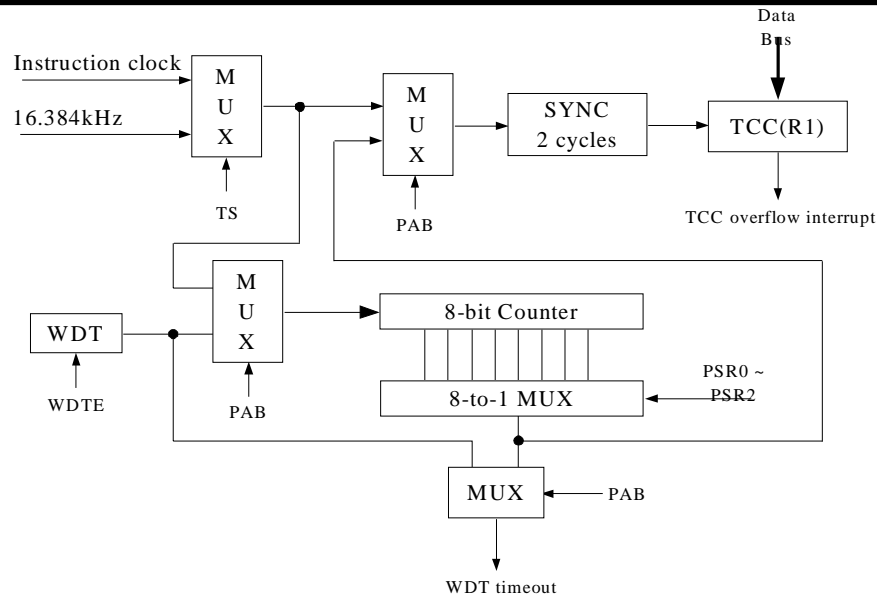

Figure 18, TCC/WDT structure

### TCC Input Timing

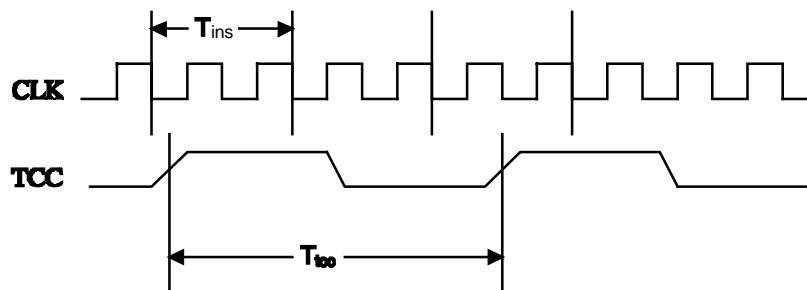

Figure 19, TCC timing

### IOC5 (PORT5 I/O control, PORT switch, CDAS, LCD bias, CASPWR) PAGE 0 (PORT5 I/O control register, PORT switch)

7	6	5	4	3	2	1	0
X	IOC56	IOC55	CASPWR	P9SH	P9SL	P8SH	P8SL
	R/W-1	R/W-1	R/W-0	R/W-0	R/W-0	R/W-0	R/W-0

**Bit 0 (P8SL):** Switch low nibble I/O PORT8 or LCD segment output for share pins SEGxx/P8x pins

0 → select normal P80 ~ P83 for low nibble PORT8

1 → select SEG64 ~ SEG67 output for LCD SEGMENT output.

**Bit 1 (P8SH):** Switch high nibble I/O PORT8 or LCD segment output for share pins SEGxx/P8x pins

0 → select normal P84 ~ P87 for high nibble PORT8

1 → select SEG68 ~ SEG71 output for LCD SEGMENT output.

**Bit 2 (P9SL):** Switch low nibble I/O PORT9 or LCD segment output for share pins SEGxx/P9x pins

0 → select normal P90 ~ P93 for low nibble PORT9

1 → select SEG72 ~ SEG75 output for LCD SEGMENT output.

**Bit 3 (P9SH):** Switch high nibble I/O PORT9 or LCD segment output for share pins SEGxx/P9x pins

0 → select normal P94 ~ P97 for high nibble PORT9

1 → select SEG76 ~ SEG79 output for LCD SEGMENT output.\*Bit 4:general register

**Bit 4 (CWPWR):** Power control of Call Waiting circuit

1/0 → enable circuit /disable circuit



**Bit 5~Bit 6(IOC55~IOC56):** PORT5 I/O direction control registers.

0 → put the relative I/O pin as output

1 → put the relative I/O pin into high impedance

**Bit 7(Unused)**

**PAGE 1 (CDAS, LCD bias control)**

7	6	5	4	3	2	1	0
X	X	X	CDAS	BIAS3	BIAS2	BIAS1	BIAS0
			R/W-0	R/W-0	R/W-0	R/W-0	R/W-0

**Bit 0~Bit 3(BIAS0~BIAS3):** LCD operation voltage selection

$$V_{diff} = VDD \times \frac{5 - \frac{n}{15}}{5}, \text{ n can be set by BIAS0~BIAS3.}$$

$$V_{LCD} = VDD - V_{diff}, \therefore V_{LCD} = VDD \times \left(1 - \frac{5 - \frac{n}{15}}{5}\right)$$

(BIAS3 to BIAS0)	$V_{diff}$ voltage	
0000	$VDD * (5-0/15)/5$	5V
0001	$VDD * (5-1/15)/5$	4.93V
0010	$VDD * (5-2/15)/5$	4.86V
0011	$VDD * (5-3/15)/5$	4.79V
0100	$VDD * (5-4/15)/5$	4.72V
:	:	:
1101	$VDD * (5-13/15)/5$	4.14V
1110	$VDD * (5-14/15)/5$	4.07V
1111	$VDD * (5-15/15)/5$	4V

Table 15, LCD operation voltage selection

\* This specification is subject to be changed without notice.



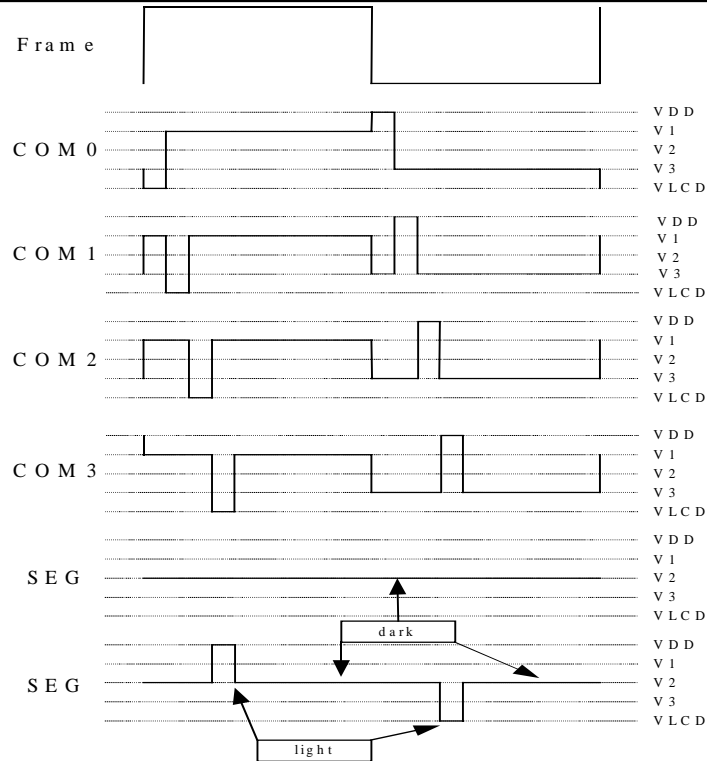

Figure 20, LCD waveform (1/4 bias) for 1/8 duty, 1/16 duty

**Bit 4(CDAS):** Current DA switch

- 0 → normal PORT66
- 1 → Current DA output

**Bit 5 ~ Bit7 (Unused)**

**PAGE 2 (Unused)**

7	6	5	4	3	2	1	0
X	X	X	X	X	X	X	X

**Bit 0 ~ Bit 7 (Unused)**

**IOC6 (PORT6 I/O control, CDA, PORT switch)**

**PAGE 0 (PORT6 I/O control register)**

7	6	5	4	3	2	1	0
X	IOC66	X	X	IOC63	IOC62	IOC61	IOC60
	R/W-1			R/W-1	R/W-1	R/W-1	R/W-1

**Bit 0~Bit 3, Bit 6 (IOC60~IOC63, IOC66):** PORT60~63, PORT66 I/O direction control register

- 0 → put the relative I/O pin as output
- 1 → put the relative I/O pin into high impedance

**Bit 4~5, 7(Unused)**

**PAGE 1 (Current DA control, DA9~DA3)**

7	6	5	4	3	2	1	0
DAEN	DA9	DA8	DA7	DA6	DA5	DA4	DA3
R/W-0	R/W-0	R/W-0	R/W-0	R/W-0	R/W-0	R/W-0	R/W-0

**Bit 0~Bit 6(DA0~DA6):** Current DA output buffer

User can use this buffer to control the output current of current DA for the driving transistor of speaker.

\* This specification is subject to be changed without notice.

**Bit 7 (DAEN):** Current DA enable control  
0/1 → disable/enable

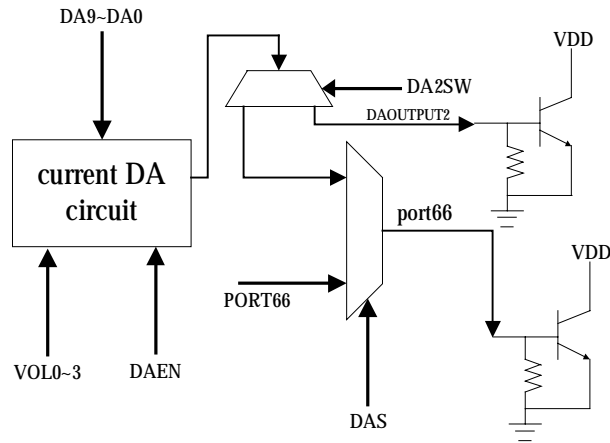

Figure 21, Current DA structure

**PAGE 2 (PORT switch, CDAL0~CDAL2)**

7	6	5	4	3	2	1	0
PCSH	PCSL	PBS	X	X	CDAL2	CDAL1	CDAL0
R/W-0	R/W-0	R/W-0	R-0	R-0	R/W-0	R/W-0	R/W-0

**Bit 0~Bit 2(DAL0~DAL2):** change output level of current DA

CDAL2	CDAL1	CDAL0	Output current (mA)
0	0	0	$5 \times 1/16 = 0.3125$
0	0	1	$5 \times 3/16 = 0.9375$
0	1	0	$5 \times 5/16 = 1.5625$
0	1	1	$5 \times 7/16 = 2.1875$
1	0	0	$5 \times 9/16 = 2.8125$
1	0	1	$5 \times 11/16 = 3.4375$
1	1	0	$5 \times 13/16 = 4.0625$
1	1	1	$5 \times 15/16 = 4.6875$

Table 16, current DAout1 output level

**Bit 3~Bit 4(Unused)**

**Bit 5(PBS):** Switch I/O PORTB or LCD segment output for share pins SEGxx/PBx

0 → select normal PB0 ~ PB7 for PORTB

1 → select SEG48 ~ SEG55 output for LCD SEGMENT output.

**Bit 6(PCSL):** Switch low nibble I/O PORTC or LCD segment output for share pins SEGxx/PCx

0 → select normal PC0 ~ PC3 for low nibble PORTC

1 → select SEG56 ~ SEG59 output for LCD SEGMENT output.

**Bit 7(PCSH):** Switch high nibble I/O PORTC or LCD segment output for share pins SEGxx/PCx

0 → select normal PC4 ~ PC7 for high nibble PORTC

1 → select SEG60 ~ SEG63 output for LCD SEGMENT output.



**IOC7 (PORT7 I/O control)**

**PAGE 0 (PORT7 I/O control register)**

7	6	5	4	3	2	1	0
IOC77	X	X	X	IOC73	IOC72	IOC71	IOC70
R/W-1				R/W-1	R/W-1	R/W-1	R/W-1

**Bit 0~Bit 3, Bit 7(IOC70~IOC73, IOC77):** PORT70~73, PORT77 I/O direction control register

0 → put the relative I/O pin as output

1 → put the relative I/O pin into high impedance

**Bit 4~6(Unused)**

**PAGE 1 (Unused)**

7	6	5	4	3	2	1	0
X	X	X	X	X	X	X	X

**Bit 0~Bit 7(Unused)**

**IOC8 (PORT8 I/O control)**

**PAGE 0 (PORT8 I/O control register)**

7	6	5	4	3	2	1	0
IOC87	IOC86	IOC85	IOC84	IOC83	IOC82	IOC81	IOC80
R/W-1	R/W-1	R/W-1	R/W-1	R/W-1	R/W-1	R/W-1	R/W-1

**Bit 0~Bit 7(IOC80~IOC87):** PORT80~87 I/O direction control register

0 → put the relative I/O pin as output

1 → put the relative I/O pin into high impedance

**PAGE 1 (Unused)**

7	6	5	4	3	2	1	0
X	X	X	X	X	X	X	X

**Bit 0~Bit 7(Unused)**

**IOC9 (PORT9 I/O control, DTMF receiver)**

**PAGE 0 (PORT9 I/O control register)**

7	6	5	4	3	2	1	0
IOC97	IOC96	IOC95	IOC94	IOC93	IOC92	IOC91	IOC90
R/W-1	R/W-1	R/W-1	R/W-1	R/W-1	R/W-1	R/W-1	R/W-1

**Bit 0~Bit 7(IOC90~IOC97):** PORT90~97 I/O direction control register

0 → put the relative I/O pin as output

1 → put the relative I/O pin into high impedance

\* This specification is subject to be changed without notice.



**PAGE1 (DTMF receiver)**

7	6	5	4	3	2	1	0
DREN	STD	TDP2	TDP1	Q4	Q3	Q2	Q1
R/W-0	R/W-0	R/W-0	R/W-0	R	R	R	R

**Bit 0~Bit 3(Q1~Q4):** DTMF receiver decoding data

To provide the code corresponding to the last valid tone-pair received (see code table). STD signal which steering output presents a logic high when a received tone-pair has been registered and the Q4 ~ Q1 output latch updated and generate a interruption (IOCF has enabled); returns to logic low when the voltage on ST/GT falls below Vtst.

TDP2	TDP1	Tdp
0	0	20 ms
0	1	15 ms
1	0	10 ms
1	1	5 ms

Table 17, Tone detection present time setup

F low	F high	Key	DREN	Q4~Q1
697	1209	1	1	0001
697	1336	2	1	0010
697	1477	3	1	0011
770	1209	4	1	0100
770	1336	5	1	0101
770	1477	6	1	0110
852	1209	7	1	0111
852	1336	8	1	1000
852	1477	9	1	1001
941	1209	0	1	1010
941	1336	*	1	1011
941	1477	#	1	1100
697	1633	A	1	1101
770	1633	B	1	1110
852	1633	C	1	1111
941	1633	D	1	0000
Any	Any	Any	0	xxxx (x:unknown)

Table 18, DTMF receiver

**Bit 4~Bit 5(TDP1, TDP2):** we recommend that keep them in [0,0] please.

**Bit 6(STD):** Delayed steering output.

Presents a logic high when a received tone-pair has been registered and the output latch updated; returns to logic low when the voltage on St/GT falls below V tst.

0/1 → Data invalid/data valid

**Bit 7(DREN):** DTMF receiver power control

0/1 → power down/ power up

Be sure open main clock before using DTMF receiver circuit . A logic low applied to DREN will shut down power of the device to minimize the power consumption in a standby mode. It stops functions of the filters.

In many situations not requiring independent selection of receive and pause, the simple steering circuit of is applicable. Component values are chosen according to the following formulae:

$$t_{REC} = t_{DP} + t_{GTP} \quad t_{ID} = t_{DA} + t_{GTA}$$

The value of t DP is a parameter of the device and t REC is the minimum signal duration to be recognized by the receiver. A value for C of 0.1 uF is recommended for most applications, leaving R to be selected by the designer. For example, a suitable value of R for a t REC of 30mS would be 300k.

\* This specification is subject to be changed without notice.

Different steering arrangements may be used to select independently the guard-times for tone-present ( $t_{GTP}$ ) and tone-absent ( $t_{GTA}$ ). This may be necessary to meet system specifications which place both accept and reject limits on both tone duration and inter digital pause.

Guard-time adjustment also allows the designer to tailor system parameters such as talk off and noise immunity. Increasing  $t_{REC}$  improves talk-off performance, since it reduces the probability that tones simulated by speech will maintain signal condition for long enough to be registered. On the other hand, a relatively short  $t_{REC}$  with a long  $t_{DO}$  would be appropriate for extremely noisy environments where fast acquisition time and immunity to drop-outs would be required.

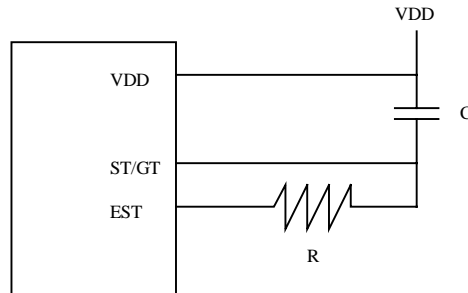

Figure 22, DTMF receiver delay time control

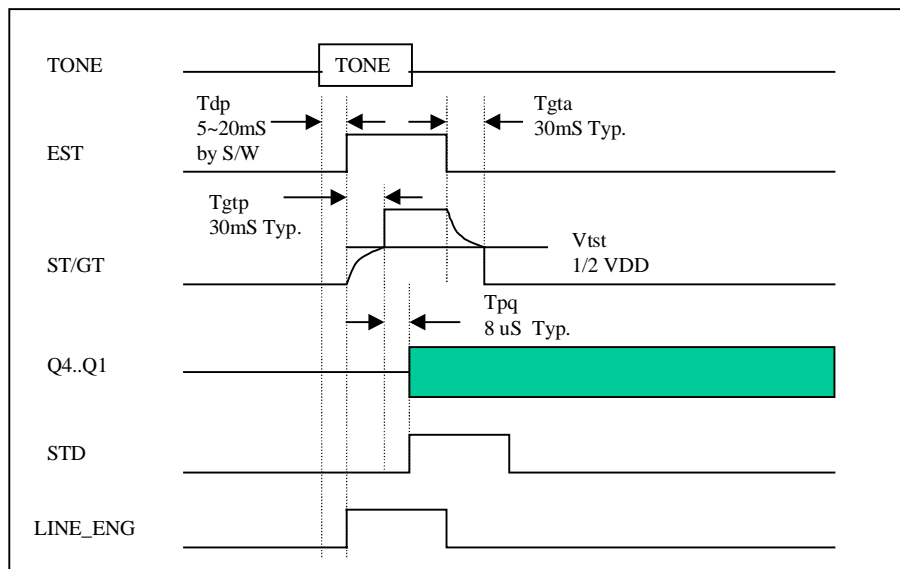

Figure 23, DTMF receiver timing



**IOCA (CN1's and CN2's clock and scaling, PORT7 pull high control)**  
**PAGE 0 (Counter1's and Counter2's clock and scale setting)**

7	6	5	4	3	2	1	0
CNT2S	C2P2	C2P1	C2P0	CNT1S	C1P2	C1P1	C1P0
R/W-0	R/W-0	R/W-0	R/W-0	R/W-0	R/W-0	R/W-0	R/W-0

**Bit 0~Bit 2(C1P0~C1P2):** Counter1 scaling

C1P2	C1P1	C1P0	COUNTER1
0	0	0	1:2
0	0	1	1:4
0	1	0	1:8
0	1	1	1:16
1	0	0	1:32
1	0	1	1:64
1	1	0	1:128
1	1	1	1:256

Table 19, counter1 scaling

**Bit 3(CNT1S):** Counter1 clock source

0/1 → 16.384kHz/instruction clock

**Bit 4~Bit 6(C2P0~C2P2):** Counter2 scaling

C2P2	C2P1	C2P0	COUNTER2
0	0	0	1:2
0	0	1	1:4
0	1	0	1:8
0	1	1	1:16
1	0	0	1:32
1	0	1	1:64
1	1	0	1:128
1	1	1	1:256

Table 20, counter2 scaling

**Bit 7(CNT2S):** Counter2 clock source

0/1 → 16.384kHz/instruction clock

**PAGE1 (PORT7 pull high control register)**

7	6	5	4	3	2	1	0
PH77	X	X	X	PH73	PH72	PH71	PH70
R/W-0				R/W-0	R/W-0	R/W-0	R/W-0

**Bit 0~Bit 3, Bit 7(PH70~PH73, PH77):** PORT70~73, PORT 77 pull high control register

0 → disable pull high function.

1 → enable pull high function

**Bit 4~6(Unused)**

**IOCB (PORTB I/O control, PORT6 pull high control)**

**PAGE 0 (PORTB I/O control register)**

7	6	5	4	3	2	1	0
IOCB7	IOCB6	IOCB5	IOCB4	IOCB3	IOCB2	IOCB1	IOCB0
R/W-1	R/W-1	R/W-1	R/W-1	R/W-1	R/W-1	R/W-1	R/W-1

**Bit 0~Bit 7(IOCB0~IOCB7) :** PORTB(0~7) I/O direction control register

0 → put the relative I/O pin as output

1 → put the relative I/O pin into high impedance

\* This specification is subject to be changed without notice.



**PAGE 1 (PORT6 pull high control register)**

7	6	5	4	3	2	1	0
X	PH66	X	X	PH63	PH62	PH61	PH60
	R/W-0			R/W-0	R/W-0	R/W-0	R/W-0

**Bit 0~Bit 3, Bit 6 (PH60~PH63, PH66):** PORT60~63, PORT66 pull high control register

0 → disable pull high function.

1 → enable pull high function

**Bit 4~5, 7(Unused)**

**IOCC (PORTC I/O control, DA0~DA2, DA2SW, VOL0~3)**

**PAGE 0 (PORT9 I/O control register)**

7	6	5	4	3	2	1	0
IOCC7	IOCC6	IOCC5	IOCC4	IOCC3	IOCC2	IOCC1	IOCC0
R/W-1	R/W-1	R/W-1	R/W-1	R/W-1	R/W-1	R/W-1	R/W-1

**Bit 0~Bit 7(IOCC0~IOCC7):** PORTC (0~7) I/O direction control register

0 → put the relative I/O pin as output

1 → put the relative I/O pin into high impedance

**PAGE 1 (DA0~DA2)**

7	6	5	4	3	2	1	0
VOL3	VOL2	VOL1	VOL0	DA2SW	DA2	DA1	DA0
R/W-0	R/W-0	R/W-0	R/W-0	R/W-0	R/W-0	R/W-0	R/W-0

**Bit0~Bit2 (DA0~DA2):** Current DA bit0~bit2

**Bit 3 (DA2SW):** This bit “1”/”0” control DAOUTPUT 2 on/off. If turn on DAOUTPUT 2 than DAOUTPUT 1 will be disable, DAOUTPUT 2 is turn off than DAOUTPUT will be enable (assume port66 as DAOUTPUT 1).

**Bit 4~7 (VOL0~VOL3):** There are four bits to control DAout2 output volume level.

VOL3 ~ VOL0	Max voice output current (mA)
0000	$5 \times 1/16 \text{ mA} = 0.3125 \text{ mA}$
0001	$5 \times 2/16 \text{ mA} = 0.625 \text{ mA}$
0010	$5 \times 3/16 \text{ mA} = 0.9375 \text{ mA}$
0011	$5 \times 4/16 \text{ mA} = 1.25 \text{ mA}$
0100	$5 \times 5/16 \text{ mA} = 1.5625 \text{ mA}$
0101	$5 \times 6/16 \text{ mA} = 1.875 \text{ mA}$
0110	$5 \times 7/16 \text{ mA} = 2.1875 \text{ mA}$
0111	$5 \times 8/16 \text{ mA} = 2.5 \text{ mA}$
1000	$5 \times 9/16 \text{ mA} = 2.8125 \text{ mA}$
1001	$5 \times 10/16 \text{ mA} = 3.125 \text{ mA}$
1010	$5 \times 11/16 \text{ mA} = 3.4375 \text{ mA}$
1011	$5 \times 12/16 \text{ mA} = 3.75 \text{ mA}$
1100	$5 \times 13/16 \text{ mA} = 4.0625 \text{ mA}$
1101	$5 \times 14/16 \text{ mA} = 4.375 \text{ mA}$
1110	$5 \times 15/16 \text{ mA} = 4.6875 \text{ mA}$
1111	5 mA

Table 21, DAout2 output volume level

\* This specification is subject to be changed without notice.



**IOCD (Counter1 data)**

**PAGE 0 (Counter1 data buffer)**

7	6	5	4	3	2	1	0
CN17	CN16	CN15	CN14	CN13	CN12	CN11	CN10
R/W-0	R/W-0	R/W-0	R/W-0	R/W-0	R/W-0	R/W-0	R/W-0

**Bit 0~Bit 7(CN10~CN17):** Counter1's data buffer

User can read and write this buffer. Counter1 is a eight bit up-counter with 8-bit prescaler that user can use IOCD to preset and read the counter. ( write = preset) After an interruption, it will reload the preset value.

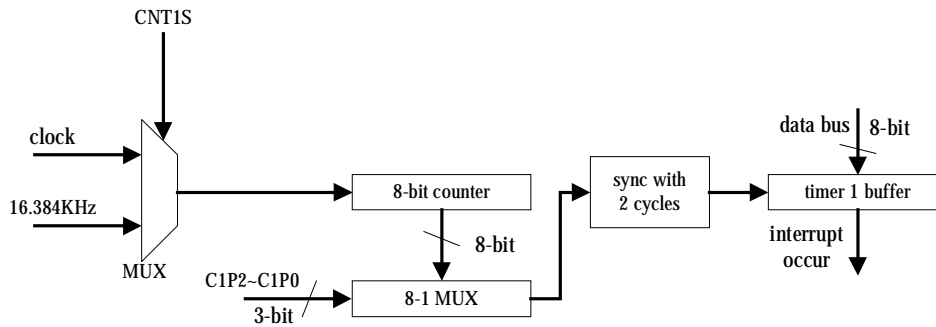

Figure 24, counter1 structure

Example:

write:

IOW 0x0D ; write the data at accumulator to counter1 (preset)

Example:

read:

IOR 0x0D ;read IOCD data and write to accumulator

**PAGE 1 (Unused)**

7	6	5	4	3	2	1	0
X	X	X	X	X	X	X	X

**Bit 0~Bit 7(Unused)**

**IOCE (Counter2 data, Comparator)**

**PAGE 0 (Counter2 data buffer)**

7	6	5	4	3	2	1	0
CN27	CN26	CN25	CN24	CN23	CN22	CN21	CN20
R/W-0	R/W-0	R/W-0	R/W-0	R/W-0	R/W-0	R/W-0	R/W-0

**Bit 0~Bit 7(CN20~CN27):** Counter2's data buffer

User can read and write this buffer. Counter2 is a eight bit up-counter with 8-bit prescaler that user can use IOCE to preset and read the counter. (write = preset) After an interruption, it will reload the preset value.

Example:

write:

IOW 0x0E ; write the data at accumulator to counter2 (preset)

Example:

read:

IOR 0x0E ;read IOCE data and write to accumulator

\* This specification is subject to be changed without notice.





**PAGE 1 (Comparator IO set)**

7	6	5	4	3	2	1	0
X	X	X	CMPIN1	P5S2	P5S1	X	X
			R/W-0	R/W-0	R/W-0		

**Bit 0 ~ Bit 1(Unused)**

**Bit 2~Bit 3 (P5S1~P5S2):** PORT5 switch

P5S2	P5S1	PORT55	PORT56	Status
0	0	PORT55	PORT56	Normal PORT5 IO
1	1	STGT	EST	DTMF receiver IO
0	1			Unused
1	0			Unused

Table 22, PORT5 switch

**Bit 4 (CMPIN1):** Switch for controlling PORT63 as IO PORT or a comparator input.

0 → IO PORT63

1 → comparator input

**Bit 5 ~ Bit 7 (Unused)**

**PAGE 2 (Energy Detector)**

7	6	5	4	3	2	1	0
VRSEL	X	X	X	X	X	X	X
R/W-0							

**Bit 0 ~ 6(Unused)**

**Bit 7 (VRSEL):** Reference voltage VR selection bit for Comparator

0/1 → VR = VDD/VR = 2.0V, When this bit is set to “0”, V2\_0 ref. circuit will be powered off.

2.0V ref. circuit is only powered on when this bit and RD page0 bit 7(CMPEN) are all set to “1”.

Notice: IOCE page 2 register is a write-only register. To avoid some un-predicted error, please don't read..

**IOCF (Interrupt Mask Register)**

7	6	5	4	3	2	1	0
RBF/STD	FSK/CW	INT2	SDTMI	INT0	CNT2	CNT1	TCIF
R/W-0	R/W-0	R/W-0	R/W-0	R/W-0	R/W-0	R/W-0	R/W-0

**Bit 0 ~ Bit 7:** Interrupt enable bits.

0/1 → disable interrupt/enable interrupt

**VII. 3 I/O Port**

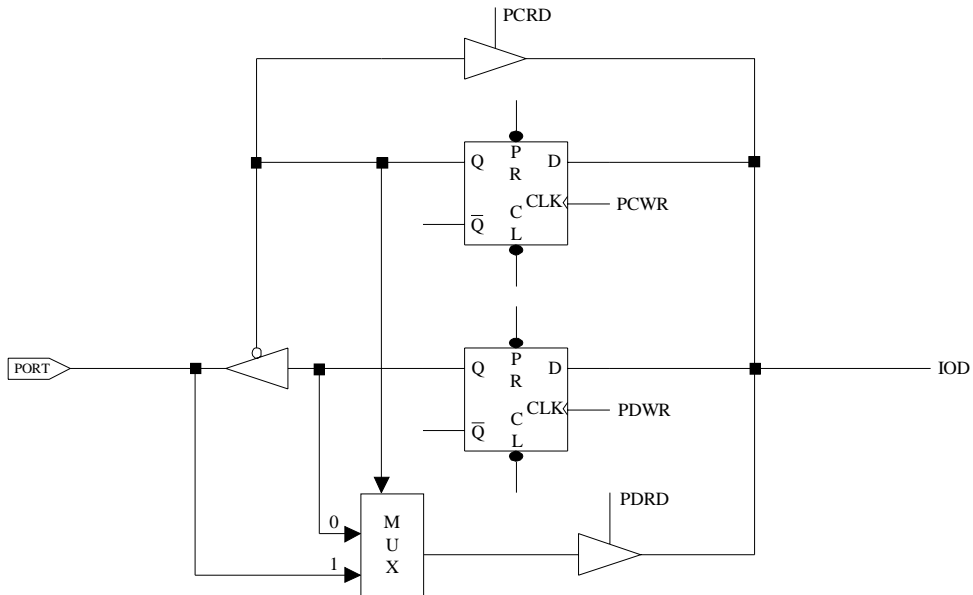

Figure 25, The circuit of I/O port and I/O control register

The I/O registers are bi-directional tri-state I/O ports. The I/O ports can be defined as "input" or "output" pins by the I/O control registers under program control. The I/O registers and I/O control registers are both readable and writable. The I/O interface circuit is shown in Fig.24



## VII. 4 RESET

The RESET can be caused by

- (1) Power on voltage detector reset (POVD) and power on reset
- (2) WDT timeout. (if enabled and in GREEN or NORMAL mode)
- (3) /RESET pin pull low

<Note> At case (1), POVD is controlled by CODE OPTION. If you enable POVD, CPU will reset at 2V under. And CPU will consume more current about 3uA. And the power on reset is a circuit always enable. It will reset CPU at about 1.4V and consume about 0.5uA.

Once the RESET occurs, the following functions are performed.

- The oscillator is running, or will be started.
- The Program Counter (R2) is set to all "0".
- When power on, the upper 3 bits of R3 and the upper 2 bits of R4 are cleared.
- The Watchdog timer and prescaler counter are cleared.
- The Watchdog timer is disabled.
- The CONT register is set to all "1"
- The other register (bit7 ~ bit0)

address	R register page0	R register page1	IOC register page0	IOC register page1	IOC register page2
4	00xxxxxx	00000000			
5	x0000000	00000000	x1100000	xxx00000	xxxxxxx
6	x0010000	xxxxxxx	x1xx1111	00000000	00000000
7	0xxx0000	xxxxxxx	1xxx1111	xxxxxxx	
8	00000000	xxxxxxx	11111111	xxxxxxx	
9	00000000	xxxxxxx	11111111	00000000	
A	0000x10	00000000	00000000	0xxx0000	
B	00000000	00000000	11111111	x0xx0000	
C	00000000	00000000	11111111	00000000	
D	0x000000	00000000	00000000	xxxxxxx	
E	1xx00000	x0xx0000	00000000	xxx000xx	00000000
F	00000000	-	00000000	-	

Table 24, registers value after reset

### RESET Timing

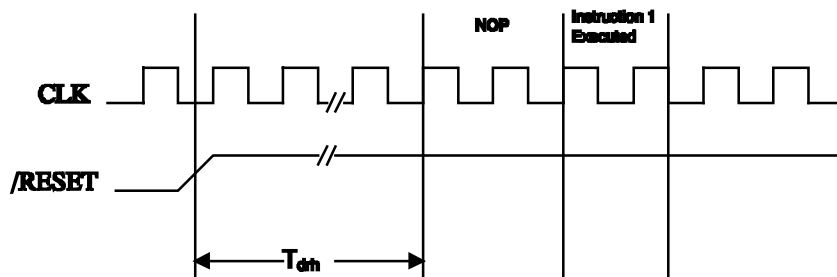

Figure 26, Reset timing

\* This specification is subject to be changed without notice.



## VII. 5 wake-up

The controller provided sleep mode for power saving.

(1) SLEEP mode, RA (7)=0 + "SLEP" instruction.

The controller will turn off all the CPU and crystal. Other circuit with power control like key tone control or PLL control (which has enable register), user has to turn it off by software.

Wake-up from SLEEP mode

- (1) WDT time out
- (2) External interrupt
- (3) /RESET pull low

All these cases will reset controller , and run the program at address zero. The status just like the power on reset. Be sure to enable circuit at case (1) or (2).

## VII. 6 Interrupt

RF is the interrupt status register, which records the interrupt request in flag bits. IOCF is the interrupt mask register. TCC timer, Counter1 and Counter2 are internal interrupt source. P70 ~ P74, P77 (INT0 ~ INT2) are external interrupt input which interrupt sources are come from the external. If the interrupts are happened by these interrupt sources, then RF register will generate '1' flag to corresponding register if you enable IOCF register. Global interrupt is enabled by ENI instruction and is disabled by DISI instruction. When one of the interrupts (when enabled) generated, will cause the next instruction to be fetched from address 008H. Once in the interrupt service routine the source of the interrupt can be determined by polling the flag bits in the RF register. The interrupt flag bit must be cleared in software before leaving the interrupt service routine and enabling interrupts to avoid recursive interrupts.

## VII. 7 Instruction Set

Instruction set has the following features:

- (1) Every bit of any register can be set, cleared, or tested directly.
- (2) The I/O register can be regarded as general register. That is, the same instruction can operates on I/O register.

The symbol "R" represents a register designator which specifies which one of the 64 registers (including operational registers and general purpose registers) is to be utilized by the instruction. Bits 6 and 7 in R4 determine the selected register bank. "b" represents a bit field designator which selects the number of the bit, located in the register "R", affected by the operation. "k" represents an 8 or 10-bit constant or literal value.

INSTRUCTION BINARY	HEX	MNEMONIC	OPERATION	STATUS AFFECTED	Instruction cycle
0 0000 0000 0000	0000	NOP	No Operation	None	1
0 0000 0000 0001	0001	DAA	Decimal Adjust A	C	1
0 0000 0000 0010	0002	CONTW	A → CONT	None	1
0 0000 0000 0011	0003	SLEP	0 → WDT, Stop oscillator	T,P	1
0 0000 0000 0100	0004	WDTC	0 → WDT	T,P	1
0 0000 0000 rrrr	000r	IOW R	A → IOCR	None	1
0 0000 0001 0000	0010	ENI	Enable Interrupt	None	1
0 0000 0001 0001	0011	DISI	Disable Interrupt	None	1
0 0000 0001 0010	0012	RET	[Top of Stack] → PC	None	2
0 0000 0001 0011	0013	RETI	[Top of Stack] → PC Enable Interrupt	None	2
0 0000 0001 0100	0014	CONTR	CONT → A	None	1
0 0000 0001 rrrr	001r	IOR R	IOCR → A	None	1
0 0000 0010 0000	0020	TBL	R2+A → R2 bits 9,10 do not clear	Z,C,DC	2
0 0000 01rr rrrr	00rr	MOV R,A	A → R	None	1
0 0000 1000 0000	0080	CLRA	0 → A	Z	1
0 0000 11rr rrrr	00rr	CLR R	0 → R	Z	1

\* This specification is subject to be changed without notice.



0	0001	00rr	rrrr	01rr	SUB A,R	$R-A \rightarrow A$	Z,C,DC	1
0	0001	01rr	rrrr	01rr	SUB R,A	$R-A \rightarrow R$	Z,C,DC	1
0	0001	10rr	rrrr	01rr	DECA R	$R-1 \rightarrow A$	Z	1
0	0001	11rr	rrrr	01rr	DEC R	$R-1 \rightarrow R$	Z	1
0	0010	00rr	rrrr	02rr	OR A,R	$A \vee R \rightarrow A$	Z	1
0	0010	01rr	rrrr	02rr	OR R,A	$A \vee R \rightarrow R$	Z	1
0	0010	10rr	rrrr	02rr	AND A,R	$A \& R \rightarrow A$	Z	1
0	0010	11rr	rrrr	02rr	AND R,A	$A \& R \rightarrow R$	Z	1
0	0011	00rr	rrrr	03rr	XOR A,R	$A \oplus R \rightarrow A$	Z	1
0	0011	01rr	rrrr	03rr	XOR R,A	$A \oplus R \rightarrow R$	Z	1
0	0011	10rr	rrrr	03rr	ADD A,R	$A + R \rightarrow A$	Z,C,DC	1
0	0011	11rr	rrrr	03rr	ADD R,A	$A + R \rightarrow R$	Z,C,DC	1
0	0100	00rr	rrrr	04rr	MOV A,R	$R \rightarrow A$	Z	1
0	0100	01rr	rrrr	04rr	MOV R,R	$R \rightarrow R$	Z	1
0	0100	10rr	rrrr	04rr	COMA R	$/R \rightarrow A$	Z	1
0	0100	11rr	rrrr	04rr	COM R	$/R \rightarrow R$	Z	1
0	0101	00rr	rrrr	05rr	INCA R	$R+1 \rightarrow A$	Z	1
0	0101	01rr	rrrr	05rr	INC R	$R+1 \rightarrow R$	Z	1
0	0101	10rr	rrrr	05rr	DJZA R	$R-1 \rightarrow A$ , skip if zero	None	2 if skip
0	0101	11rr	rrrr	05rr	DJZ R	$R-1 \rightarrow R$ , skip if zero	None	2 if skip
0	0110	00rr	rrrr	06rr	RCCA R	$R(n) \rightarrow A(n-1)$ $R(0) \rightarrow C, C \rightarrow A(7)$	C	1
0	0110	01rr	rrrr	06rr	RRC R	$R(n) \rightarrow R(n-1)$ $R(0) \rightarrow C, C \rightarrow R(7)$	C	1
0	0110	10rr	rrrr	06rr	RLCA R	$R(n) \rightarrow A(n+1)$ $R(7) \rightarrow C, C \rightarrow A(0)$	C	1
0	0110	11rr	rrrr	06rr	RLC R	$R(n) \rightarrow R(n+1)$ $R(7) \rightarrow C, C \rightarrow R(0)$	C	1
0	0111	00rr	rrrr	07rr	SWAPA R	$R(0-3) \rightarrow A(4-7)$ $R(4-7) \rightarrow A(0-3)$	None	1
0	0111	01rr	rrrr	07rr	SWAP R	$R(0-3) \leftrightarrow R(4-7)$	None	1
0	0111	10rr	rrrr	07rr	JZA R	$R+1 \rightarrow A$ , skip if zero	None	2 if skip
0	0111	11rr	rrrr	07rr	JZ R	$R+1 \rightarrow R$ , skip if zero	None	2 if skip
0	100b	brrr	rrrr	0xxx	BC R,b	$0 \rightarrow R(b)$	None	1
0	101b	brrr	rrrr	0xxx	BS R,b	$1 \rightarrow R(b)$	None	1
0	110b	brrr	rrrr	0xxx	JBC R,b	if $R(b)=0$ , skip	None	2 if skip
0	111b	brrr	rrrr	0xxx	JBS R,b	if $R(b)=1$ , skip	None	2 if skip
1	00kk	kkkk	kkkk	1kkk	CALL k	$PC+1 \rightarrow [SP]$ $(Page, k) \rightarrow PC$	None	2
1	01kk	kkkk	kkkk	1kkk	JMP k	$(Page, k) \rightarrow PC$	None	2
1	1000	kkkk	kkkk	18kk	MOV A,k	$k \rightarrow A$	None	1
1	1001	kkkk	kkkk	19kk	OR A,k	$A \vee k \rightarrow A$	Z	1
1	1010	kkkk	kkkk	1Akk	AND A,k	$A \& k \rightarrow A$	Z	1
1	1011	kkkk	kkkk	1Bkk	XOR A,k	$A \oplus k \rightarrow A$	Z	1
1	1100	kkkk	kkkk	1Ckk	RETL k	$k \rightarrow A, [Top\ of\ Stack] \rightarrow PC$	None	2
1	1101	kkkk	kkkk	1Dkk	SUB A,k	$k-A \rightarrow A$	Z,C,DC	1
1	1110	0000	0001	1E01	INT	$PC+1 \rightarrow [SP]$ $001H \rightarrow PC$	None	1
1	1110	100k	kkkk	1E8k	PAGE k	$K \rightarrow R5(4:0)$	None	1
1	1111	kkkk	kkkk	1Fkk	ADD A,k	$k+A \rightarrow A$	Z,C,DC	1

1 instruction cycle = 2 main clock.

Table 25, instructions overview

\* This specification is subject to be changed without notice.



## VII. 8 CODE Option Register

The controller has one CODE option register, which is not part of the normal program memory. The option bits cannot be accessed during normal program execution.

### CODE Option Register1 (Program ROM)

7	6	5	4	3	2	1	0
-	-	CWMODE	-	-	-	-	/POT

**Bit 0(/POT):** program ROM protect option

If set 1 to the bit, program memory can be access; else if clear this bit, program memory can be written only.

**Bit 2~4(Unused)**

**Bit 5(CWMODE):** CAS tone (2130 Hz plus 2750 Hz) accepted frequency range deviation select.

0 → ±2% Call waiting accepted frequency range deviation.(Application for China protocol : ±1.5% )

1 → ±1.2% Call waiting accepted frequency range deviation.(Application for Europe and USA protocol : ±0.5% )

**Bit 6~7(Unused)**

## VII. 8. 1 PAD Option

### PAD Option

Please refer to figure2-1 in page 6. /POVD function will be decided to enable or disable by VDTBL or VDTBH pin.

/POVD	Pin connect	2.2V reset	Power on reset 2.0V	sleep mode current
1	VDTBH connect to VDD and VDTBL floated	No	yes	1uA
0	VDTBL connect to GND and VDTBH floated	Yes	yes	10uA

Table 26, /POVD

Note: In instruction table, “MOV R, R”, R must be the same register.

\* This specification is subject to be changed without notice.

## VII. 9 CALL WAITING Function Descriptions

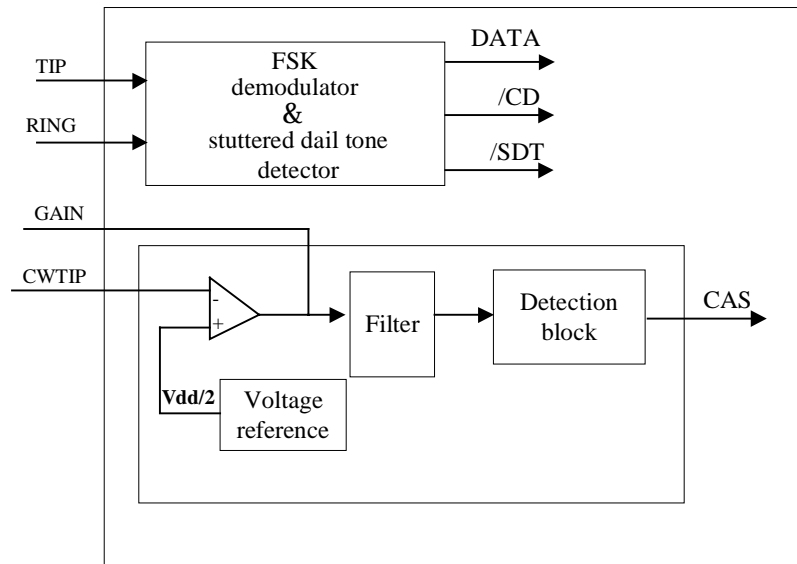

Figure 27, Call Waiting Block Diagram

Call Waiting service works by alerting a customer engaged in a telephone call to a new incoming call. This way the customer can still receive important calls while engaged in a current call. The CALL WAITING DECODER can detect CAS(Call-Waiting Alerting Signal 2130Hz plus 2750Hz) and generate a valid signal on the data pins.

The call waiting decoder is designed to support the Caller Number Deliver feature, which is offered by regional Bell Operating Companies.

In a typical application, after enabling CW circuit (by IOC5 page0 bit4 CWPWR) this IC receives Tip and Ring signals from twisted pairs. The signals as inputs of pre-amplifier, and the amplifier sends input signal to a band pass filter. Once the signal is filtered, the Detection block decodes the information and sends it to R3 register bit7 . The output data made available at R3 CAS bit.

The data is CAS signals. The CAS is normal high. When this IC detects 2130Hz and 2750Hz frequency, then CAS pin goes to low.

## VII. 11 Stuttered dial tone detect (SDT)

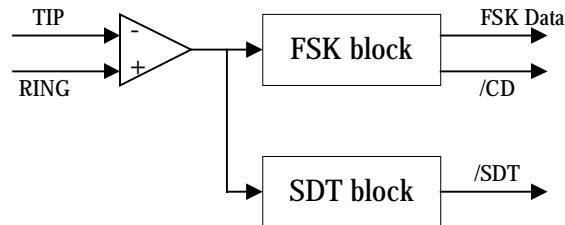

Figure 29, SDT block

SDT (Stuttered dial tone) circuit and FSK circuit use the same input OP Amp. When SDTPWR bit (bit 5 of register R6) is set, SDT circuit is powered on and SDT detection is enabled. SDT detection enable means it is power on and detect 350Hz plus 440Hz dual frequency. And SDT signal detection output is sent to /SDT bit (bit 4 of register R6) with low enable.

If SDT circuit works, it consists of high-band and low-band pass tone filter, level detect, frequency counting and digital algorithm to qualify timing.





## VIII. Absolute Operation Maximum Ratings

RATING	SYMBOL	VALUE	UNIT
DC SUPPLY VOLTAGE	VDD	-0.3 To 6	V
INPUT VOLTAGE	V <sub>in</sub>	-0.5 to VDD +0.5	V
OPERATING TEMPERATURE RANGE	T <sub>a</sub>	0 to 70	°C

## IX. DC Electrical Characteristic

(Operation current consumption for Analog circuit)

Parameter	Symbol	Condition	Min	Typ	Max	Unit
Operation current for FSK	I <sub>FSK</sub>	VDD=5V, CID power on		2.5	4.0	mA
		VDD=3V, CID power on		2.0	3.5	
Operation current for CW	I <sub>CW</sub>	VDD=5V, CID power on		2.5	4.0	mA
		VDD=3V, CID power on		2.0	3.5	
Operation current for DTMF receiver	I <sub>DR</sub>	VDD=3V, DTMFr power on		2.5	4.0	mA
		VDD=3V, DTMFr power on		2.0	3.5	
Current DA output current	I <sub>DA</sub>	VDD=5V, CDA power on		2.5	4	mA
		VDD=3V, CDA power on		2.0	3.5	
Operation current for Comparator	I <sub>CMP</sub>	VDD=5V, PT power on		0.15	0.3	mA
		VDD=3V, PT power on		0.13	0.2	
SDT	I <sub>SDT</sub>	VDD=5V, SDT power on		1.8	3.3	mA
		VDD=3V, SDT power on		1.5	3.0	

(T<sub>a</sub>=25°C, VDD=5V±5%, VSS=0V)

Parameter	Symbol	Condition	Min	Typ	Max	Unit
Input Leakage Current for input pins	IIL1	VIN = VDD, VSS			±1	μA
Input Leakage Current for bi-directional pins	IIL2	VIN = VDD, VSS			±1	μA
Input High Voltage	VIH		2.0			V
Input Low Voltage	VIL				0.8	V
Input High Threshold Voltage	VIHT	/RESET, TCC, RDET1	2.0			V
Input Low Threshold Voltage	VILT	/RESET, TCC, RDET1			0.8	V
Clock Input High Voltage	VIHX	OSCI	1.8			V
Clock Input Low Voltage	VILX	OSCI			1.2	V
Output High Voltage (port5,8,9,B,C)	VOH1	IOH = -5mA	2.0			V
		IOH = -8mA	2.0			
Output Low Voltage (port5,8,9,B,C)	VOL1	IOL = 5mA			0.4	V
		IOL = 8mA			0.4	
Pull-high current	IPH	Pull-high active input pin at VSS		-10	-15	μA
Power down current (SLEEP mode)	ISB1	All input and I/O pin at VDD, output pin floating, WDT disabled		1	4	μA

\* This specification is subject to be changed without notice.



Low clock current (GREEN mode)	ISB2	CLK=32.768KHz, All analog circuit disable , All input and I/O pin at VDD, output pin floating, WDT disabled, LCD disable	35	50	μA
Operating supply current (NORMAL mode)	ICC	/RESET=High, PLL enable CLK=3.579MHz, output pin floating and LCD enable, all analog circuit disable	2.8	3.5	mA
Tone generator reference voltage	Vref2		0.5	0.7	VDD

## X. AC Electrical Characteristic

CPU instruction timing (Ta=25°C, VDD=5V, VSS=0V)

Parameter	Symbol	Condition	Min	Typ	Max	Unit
Input CLK duty cycle	Dclk		45	50	55	%
Instruction cycle time	Tins	32.768kHz 3.579MHz		60 550		us ns
Device delay hold time	Tdrh			16		ms
TCC input period	Ttcc	Note 1	(Tins+20)/N			ns
Watchdog timer period	Twdt	Ta = 25°C		16		ms

Note 1: N= selected prescaler ratio.

FSK AC Characteristic (Vdd=5V, Ta=+25°C)

CHARACTERISTIC	Min	Typ	Max	Unit
<b>FSK sensitivity</b>				
Low Level Sensitivity Tip & Ring @SNR 20dB	-40	-48		dBm
High Level Sensitivity Tip & Ring @SNR 20dB		0		dBm
Signal Reject		-51		dBm
<b>FSK twist</b>				
Positive Twist (High Level)	+10			dB
Positive Twist (Low Level)	+10			dB
Negative Twist (High Level)	-6			dB
Negative Twist (Low Level)	-6			dB

CW AC Characteristic (Vdd=5V, Ta=+25°C)

CHARACTERISTIC	Min	Typ	Max	Unit
<b>CW sensitivity</b>				
Sensitivity @SNR 20dB		-38		dBm
Low Tone Frequency 2130Hz		±1.2		%
High Tone Frequency 2750Hz		±1.2		%
<b>CW twist</b>				
Twist	±7			dB



DTMFr (DTMF receiver) AC Characteristic (Vdd=5V, Ta=+25°C)

CHARACTERISTIC	Min	Typ	Max	Unit
<b>DTMFr</b>				
Low Level Signal Sensitivity		-36		dBm
High Level Signal Sensitivity		0		dBm
Low Tone Frequency		±2		%
High Tone Frequency		±2		%
<b>DTMFr noise endurance</b>				
Signal to noise ratio	15			dB

Timing characteristic (Vdd=5V, Ta=+25°C)

Description	Symbol	Min	Typ	Max	Unit
<b>Oscillator timing characteristic</b>					
OSC start up	32.768kHz	Tosc		500	ms
	3.579MHz PLL			10	
<b>FSK timing characteristic</b>					
Carrier detect low	Tcdl	--	10	20	ms
Data out to Carrier det low	Tdoc	--	10	20	ns
Power up to FSK(setup time)	Tsup	--	15	20	ms
End of FSK to Carrier Detect high	Tcdh		-	5	ms
<b>CW timing characteristic</b>					
CAS input signal length (2130, 2750 Hz @ -20dBm )	Tcasi		80		ms
Call waiting data detect delay time	Tc wd		42		ms
Call waiting data release time	Tc wr		26		ms
<b>DTMF receiver timing characteristic</b>					
Tone Present Detection Time	Tdp		(ps1)		
the guard-times for tone-present (C=0.1uF, R=300K)	Tgtp		30		ms
the guard-times for tone-absent (C=0.1uF, R=300K)	Tgta		30		mS
Propagation Delay (St to Q)	Tpq		8		us
Tone Absent Detection Time	Tda		(ps2)		ms
<b>SPI timing characteristic (CPU clock 3.58MHz and Fsc0 = 3.58Mhz /2)</b>					
/SS set-up time	Tcss	560			ns
/SS hold time	Tcsh	250			
SCLK high time	Thi	250			ns
SCLK low time	Tlo	250			ns
SCLK rising time	Tr		15	30	ns
SCLK falling time	Tf		15	30	ns
SDI set-up time to the reading edge of SCLK	Tisu	25			ns
SDI hold time to the reading edge of SCLK	Tihd	25			ns
SDO disable time	Tdis			560	ns

(ps1) : Controlled by software  
(ps2) : Controlled by RC circuit.



SDT characteristic

	Min	Typ	Max	Unit
SDT characteristic				
Input sensitivity Tip & Ring pins, VDD=5.0V		-38		dBm
Input frequency tolerance		± 2.0		%
SDT timing characteristic				
SDT signal detect delay time		30		ms
SDT signal release tme		30		ms

## XI. Timing Diagrams

### AC Test Input/Output Waveform

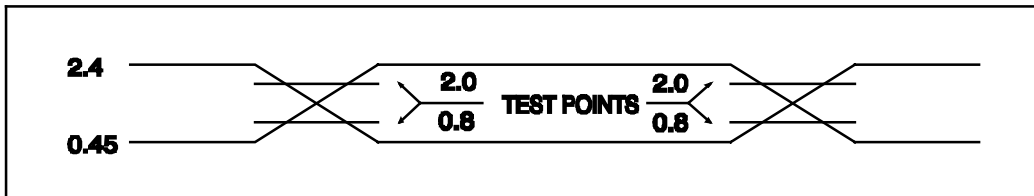

**AC Testing: Input are driven at 2.4V for logic "1", and 0.45V for logic "0". Timing measurements are made at 2.0V for logic "1", and 0.8V for logic "0".**

Figure 30, AC test timing

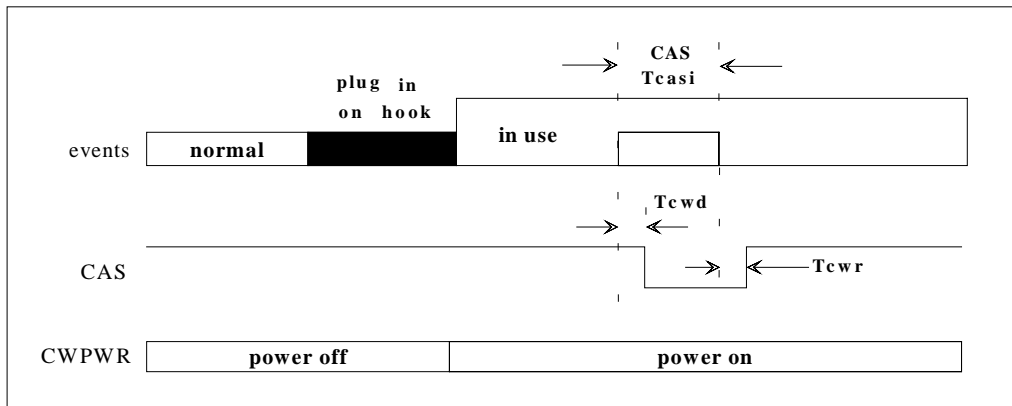

Figure 31, Call waiting timing

## XII. Application Circuit

Using 78P915 build-in LCD driver

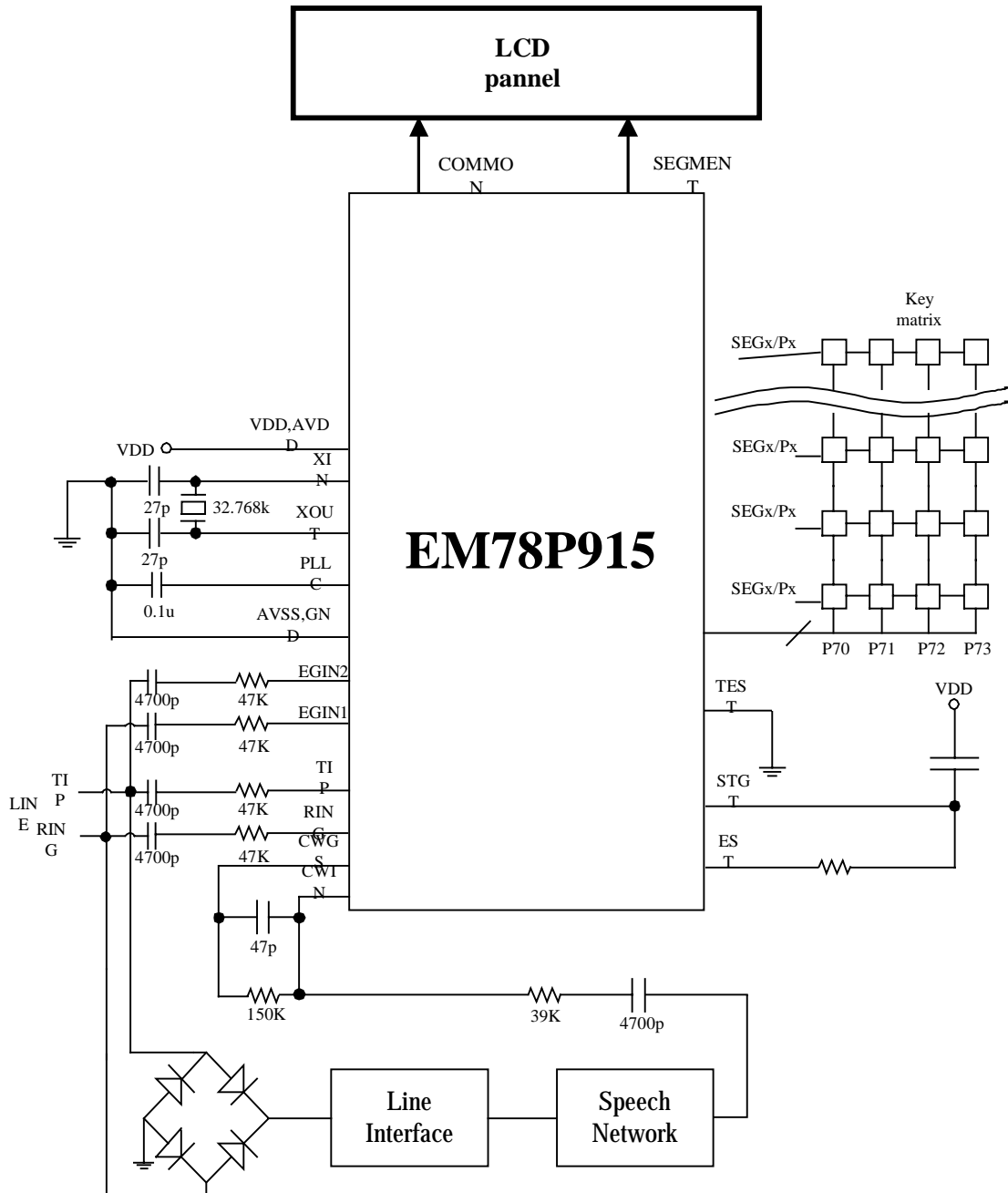

Figure 32, Use 78915 build-in LCD driver circuit



---

---

### XIII. Program Pins location of EM78P915

Port	Name	Note
P70	ACLK	
P71	DINCLK	
P72	PGMB	
P73	OEB	
P77	Data I/O	

Table 28, program pin location



---

---

## Appendix

### A. Operational/special purpose/code option registers location

#### Operational register

R0 .....	12
R1 .....	12
R2 .....	12
R3 .....	12
R4 .....	13
R5 .....	16
R6 .....	17
R7 .....	17
R8 .....	17
R9 .....	18
RA .....	18
RB .....	21
RC .....	22
RD .....	22
RE .....	24
RF .....	26

#### Special purpose registers

CONT .....	28
IOC5 .....	29
IOC6 .....	31
IOC7 .....	33
IOC8 .....	33
IOC9 .....	33
IOCA .....	36
IOCB .....	36
IOCC .....	37
IOCD .....	38
IOCE .....	38
IOCF .....	40

#### Code option registers

Code option register1 .....	45
PAD option register1 .....	45





**B. Figure/table list**

**Figure list**

Figure 1, Register overview description.....	2
Figure 2, Pin assignment.....	6
Figure 3, Block diagram.....	7
Figure 4, operational registers overview.....	10
Figure 5, Special purpose registers overview.....	10
Figure 6, general purpose registers 10 ~ 1F.....	11
Figure 7, general purpose registers 20 ~ 3F in Bank0/1/2/3.....	11
Figure 8, program counter organization.....	12
Figure 9, Single SPI Master / Salve Communication.....	14
Figure 10, SPI structure.....	15
Figure 11, SPI timing.....	16
Figure 12, the relation between bit 1 ~ bit 3 of FSK in RA.....	19
Figure 13, the relation between 32.768kHz and PLL.....	20
Figure 14, Comparator timing.....	23
Figure 15, Comparator circuit.....	23
Figure 16, key scan waveform for 1/8, 1/16 duty.....	25
Figure 17, KEYSCAN and segments.....	25
Figure 18, TCC/WDT structure.....	29
Figure 19, TCC timing.....	29
Figure 20, LCD waveform (1/4 bias) for 1/8 duty, 1/16 duty.....	31
Figure 21, Current DA structure.....	32
Figure 22, DTMF receiver delay time control.....	35
Figure 23, DTMF receiver timing.....	35
Figure 24, counter1 structure.....	38
Figure 25, The circuit of I/O port and I/O control register.....	41
Figure 26, Reset timing.....	42
Figure 27, Call Waiting Block Diagram.....	46
Figure 29, SDT block.....	48
Figure 30, AC test timing.....	52
Figure 31, Call waiting timing.....	52
Figure 32, Use 78915 build-in LCD driver circuit.....	53

**Table list**

Table 1, initial setting reference in using ICE915.....	2
Table 2, Event for power down bit and timer out bit.....	13
Table 3, relation with IOCPI5 bit and IOCPAGE bit.....	13
Table 4, SPI baud rate selection.....	14
Table 5, program page selection.....	16
Table 6, main clock selection.....	19
Table 7, sleep/green/normal modes with wake up signal.....	20
Table 8, Common/Segment signal.....	21
Table 9, channel selection of CMP.....	22
Table 10, LCD common mode.....	24
Table 11, LCD operation function define.....	24
Table 12, relation with Duty mode and COM.....	24
Table 13, interrupt trigger.....	27
Table 14, pre-scale of TCC and WDT.....	28
Table 15, LCD operation voltage selection.....	30
Table 16, current DA output level.....	32
Table 17, DTMF receiver.....	34
Table 18, Tone detection present time setup.....	34
Table 19, counter1 scaling.....	36
Table 20, counter2 scaling.....	36
Table 21, output volume level.....	37
Table 22, PORT5 switch.....	39
Table 24, registers value after reset.....	42

\* This specification is subject to be changed without notice.



Table 25, instructions overview.....	44
Table 26, /POVD.....	45
Table 28, program pin location.....	54

**C. EM78P915/915 family list**

Type	OTP	OTP	OTP	OTP	Note
Product NO.	P915/915	P914/914	P916/916	P880/880	
<b>Kernel</b>					
Operation voltage	2.2V ~ 5.5V	2.2V ~ 5.5V	2.2V ~ 5.5V	2.2V ~ 5.5V	
Operation clock <sub>MAX</sub>	10.74MHz	10.74MHz	10.74MHz	10.74MHz	
Program ROM size	32K*13	32K*13	32K*13	32K*13	
8-bit WDT*1	√	√	√	√	
8-bit TCC*1	√	√	√	√	
Interruption	Internal INT*3	Internal INT*3	Internal INT*3	Internal INT*3	
	External INT*7	External INT*5	External INT*7	External INT*3	
Stack level	8	8	8	8	
Counter	8-bit CNT*2	8-bit CNT*2	8-bit CNT*2	8-bit CNT*2	
Data RAM size	2.5K*8	2.5K*8	2.5K*8	2.5K*8	
Idle mode	√	√	√	√	
Sleep mode	√	√	√	√	
I/O Port <sub>MAX</sub>	44 bi-direction	44 bi-direction	44 bi-direction	44 bi-direction	
/POVD level	2.2V	2.2V	2.2V	2.2V	
POR level	2.0V	2.0V	2.0V	2.0V	
<b>Digital IP circuit</b>					
SPI	√	√	√	√	
10-bit CDA	√	√	√	√	
<b>Analog IP circuit</b>					
LCD	√	√		√	
LCD pin number	COM: 16 SEG: 60	COM: 16 SEG: 60		COM: 16 SEG: 60	
LCD bias and duty	Bias: 1/4	Bias: 1/4		Bias: 1/4	
	Duty: 1/8, 1/16	Duty: 1/8, 1/16		Duty: 1/8, 1/16	
Call waiting	√		√		
FSK decode	√	√	√		
DTMF receiver	√	√	√		
DED	√				
SDT decode	√		√		
Comparator	√	√	√	√	

Note: symbol “√” is represent the function existed. If the space is empty, the function is disabled or un-existed.

**D. Development tool and reference document for EM78P915/915 family**

Product (OTP/Mask) NO.	P915/915	P914/914	P916/916	P880/880
Development tool				
ICE (ROM-Less) NO.	ICE915	ICE915	ICE915	ICE915
WICE version	2.993-051004 or above	2.993-051004 or above	2.993-051004 or above	2.993-051004 or above
Writer S/W version	3.1 or above	3.1 or above	3.1 or above	3.1 or above
Writer H/W version	3.1 or above	3.1 or above	3.1 or above	3.1 or above
Reference document	Chapter 2 of ICE915 family user guide	Chapter 3 of ICE915 family user guide	Chapter 4 of ICE915 family user guide	Chapter 5 of ICE915 family user guide

Note: if users want to develop products by using P915/915, these tools such as ICE915, WICE, reference documents and Writer are necessary tools for developing and debugging level.

**E. ICE915 in WICE**

Step1: Download WICE steup.exe file from our web site [www.emc.com.tw](http://www.emc.com.tw)

Step2: Setup WICE. (In this description, we only introduce about ICE915 in WICE, but more detail about WICE using, users have to refer to WICE manual please)

Step3: Choice your ICE NO. (ICE915, ICE914, ICE916 or ICE880) and press “OK” button after executed WICE. If users can't find ICE NO. Please presses “Cancel” and refer to step4 to check WICE version.

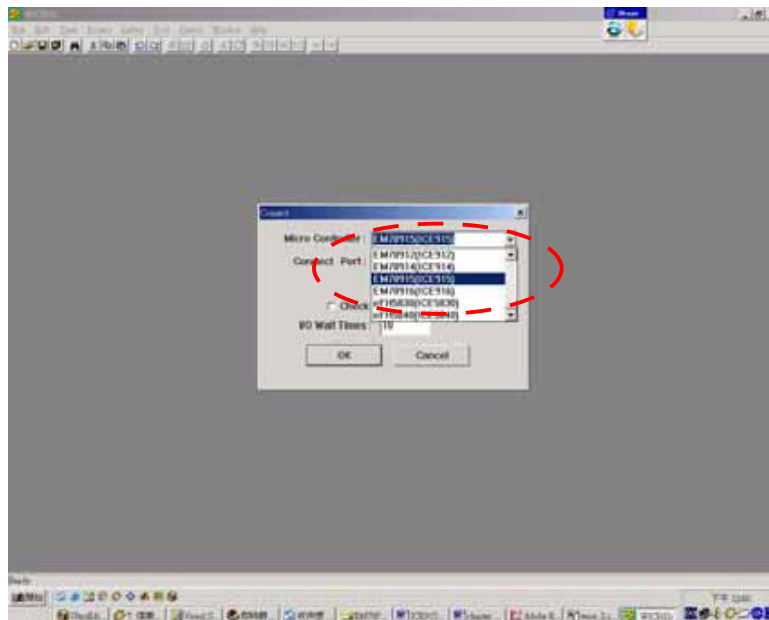

Step4: Check WICE version after installed, the number must be 2.993-051004 or above. If version is older than this number, please update your WICE.

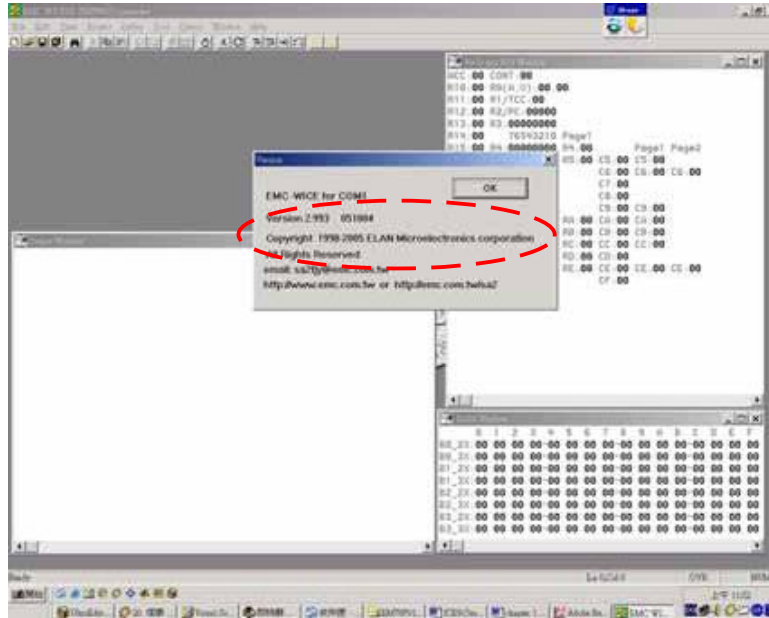

**F. Program EM78P915 note**

Step1: Please check your tools. It has to include WTRFI S/W and WTRFI H/W. And remember to confirm their version first.

Step2: The connection between WTRFI H/W, PC, EM78P915

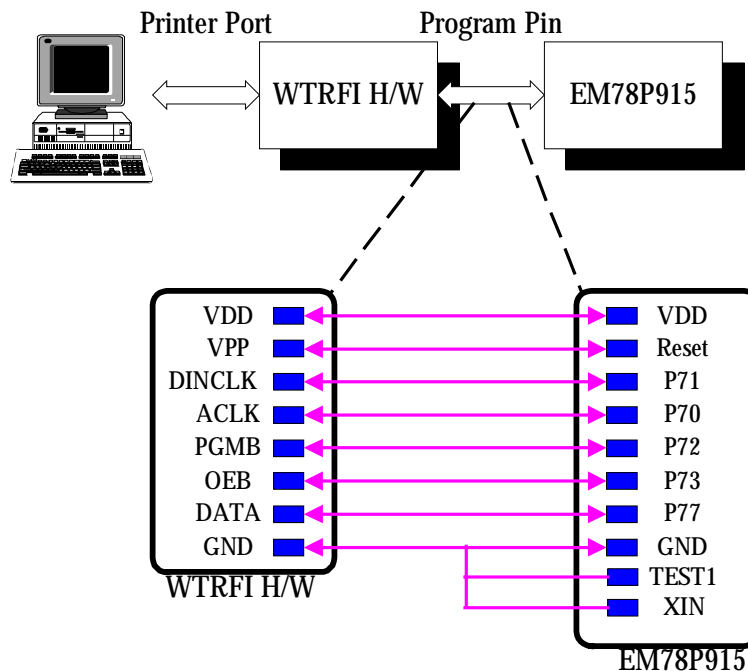

Step3: After executed WTRFI S/W and choice 915, users can write/read code from EM78P915. More detail description about WTRFI S/W and H/W, users can refer to WTRFI manual.

\* This specification is subject to be changed without notice.