

Horizontal Genlock, 8F_{SC}

The EL4585 is a PLL (Phase Lock Loop) sub-system, designed for video applications and also suitable for general purpose use up to 36MHz. In video applications, this device generates a TTL/CMOS-compatible pixel clock (CLK OUT) which is a multiple of the TV horizontal scan rate and phase locked to it.

The reference signal is a horizontal sync signal, TTL/CMOS format, which can be easily derived from an analog composite video signal with the EL4583 sync separator. An input signal to "coast" is provided for applications where periodic disturbances are present in the reference video timing such as VTR head switching. The lock detector output indicates correct lock.

The divider ratio is four ratios for NTSC and four similar ratios for the PAL video timing standards by external selection of three control pins. These four ratios have been selected for common video applications including 8F_{SC}, 6F_{SC}, 27MHz (CCIR 601 format) and square picture elements used in some workstation graphics. To generate 4F_{SC}, 3F_{SC}, 13.5MHz (CCIR 601 format) etc., use the EL4584, which does not have the additional divide-by-two stage of the EL4585.

For applications where these frequencies are inappropriate or for general purpose PLL applications the internal divider can be bypassed and an external divider chain used.

FREQUENCIES AND DIVISORS

FUNCTION	6F _{SC} (NOTE 1)	CCIR 601 (NOTE 2)	SQUARE (NOTE 3)	8F _{SC}
Divisor (Note 4)	1702	1728	1888	2270
PAL F _{OSC} (MHz)	26.602	27.0	29.5	35.468
Divisor (Note 4)	1364	1716	1560	1820
NTSC F _{OSC} (MHz)	21.476	27.0	24.546	28.636

NOTES:

1. 6F_{SC} frequencies do not yield integer divisors.
2. CCIR 601 divisors yield 1440 pixels in the active portion of each line for NTSC and PAL.
3. Square pixels format gives 640 pixels for NTSC and 768 pixels for PAL.
4. Divisor does not include ÷ 2 block.

Features

- 36MHz, general purpose PLL
- 8F_{SC} timing (use the EL4584 for 4F_{SC})
- Compatible with EL4583 sync separator
- VCXO, Xtal, or LC tank oscillator
- < 2ns jitter (VCXO)
- User-controlled PLL capture and lock
- Compatible with NTSC and PAL TV formats
- 8 pre-programmed popular TV scan rate clock divisors
- Single 5V, low current operation
- Pb-Free Plus Anneal Available (RoHS Compliant)

Applications

- Pixel clock regeneration
- Video compression engine (MPEG) clock generator
- Video capture or digitization
- PIP (Picture in Picture) timing generator
- Text or graphics overlay timing

Ordering Information

PART NUMBER	PACKAGE	TAPE & REEL	PKG. DWG. #
EL4585CN	16-Pin PDIP	-	MDP0031
EL4585CS	16-Pin SO (0.150")	-	MDP0027
EL4585CS-T7	16-Pin SO (0.150")	7"	MDP0027
EL4585CS-T13	16-Pin SO (0.150")	13"	MDP0027
EL4585CSZ (See Note)	16-Pin SO (0.150") (Pb-free)	-	MDP0027
EL4585CSZ-T7 (See Note)	16-Pin SO (0.150") (Pb-free)	7"	MDP0027
EL4585CSZ-T13 (See Note)	16-Pin SO (0.150") (Pb-free)	13"	MDP0027

*For 3F_{SC} and 4F_{SC} clock frequency operation, see EL4584 datasheet.

NOTE: Intersil Pb-free plus anneal products employ special Pb-free material sets; molding compounds/die attach materials and 100% matte tin plate termination finish, which are RoHS compliant and compatible with both SnPb and Pb-free soldering operations. Intersil Pb-free products are MSL classified at Pb-free peak reflow temperatures that meet or exceed the Pb-free requirements of IPC/JEDEC J STD-020.

Demo Board

A demo PCB is available for this product.

Pinout

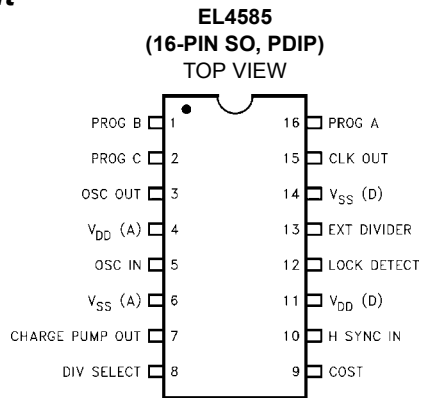

Absolute Maximum Ratings ($T_A = 25^\circ\text{C}$)

V _{CC} Supply7V	Operating Junction Temperature	+125°C
Storage Temperature	-65°C to +150°C	Power Dissipation	400mW
Pin Voltages	-0.5V to V _{CC} +0.5V	Oscillator Frequency	36MHz
Operating Ambient Temperature Range	-40°C to +85°C		

CAUTION: Stresses above those listed in "Absolute Maximum Ratings" may cause permanent damage to the device. This is a stress only rating and operation of the device at these or any other conditions above those indicated in the operational sections of this specification is not implied.

IMPORTANT NOTE: All parameters having Min/Max specifications are guaranteed. Typical values are for information purposes only. Unless otherwise noted, all tests are at the specified temperature and are pulsed tests, therefore: $T_J = T_C = T_A$

DC Electrical Specifications $V_{DD} = 5V, T_A = 25^\circ\text{C}$ unless otherwise noted

Parameter	Conditions	Min	Typ	Max	Unit
I _{DD}	V _{DD} = 5V (Note 1)		2	4	mA
V _{IL} Input Low Voltage				1.5	V
V _{IH} Input High Voltage		3.5			V
I _{IL} Input Low Current	All inputs except COAST, V _{IN} = 1.5V	-100			nA
I _{IH} Input High Current	All inputs except COAST, V _{IN} = 3.5V			100	nA
I _{IL} Input Low Current	COAST pin, V _{IN} = 1.5V	-100	-60		μA
I _{IH} Input High Current	COAST pin, V _{IN} = 3.5V		60	100	μA
V _{OL} Output Low Voltage	Lock Det, I _{OL} = 1.6mA			0.4	V
V _{OH} Output High Voltage	Lock Det, I _{OH} = -1.6mA	2.4			V
V _{OL} Output Low Voltage	CLK, I _{OL} = 3.2mA			0.4	V
V _{OH} Output High Voltage	CLK, I _{OH} = -3.2mA	2.4			V
V _{OL} Output Low Voltage	OSC Out, I _{OL} = 200μA			0.4	V
V _{OH} Output High Voltage	OSC Out, I _{OH} = -200μA	2.4			V
I _{OL} Output Low Current	Filter Out, V _{OUT} = 2.5V	200	300		μA
I _{OH} Output High Current	Filter Out, V _{OUT} = 2.5V		-300	-200	μA
I _{OL} /I _{OH} Current Ratio	Filter Out, V _{OUT} = 2.5V	1.05	1.0	0.95	
I _{LEAK} Filter Out	Coast Mode, V _{DD} > V _{OUT} > 0V	-100	±1	100	nA

NOTE:

1. All inputs to 0V, COAST floating.

AC Electrical Specifications $V_{DD} = 5V, T_A = 25^\circ\text{C}$ unless otherwise noted

Parameter	Conditions	Min	Typ	Max	Unit
VCO Gain @ 20MHz	Test circuit 1		15.5		dB
H _{SYNC} S/N Ratio	V _{DD} = 5V (Note 1)	35			dB
Jitter	VCXO oscillator		1		ns
Jitter	LC oscillator (Typ)		10		ns

NOTE:

1. Noisy video signal input to EL4583, H_{SYNC} input to EL4585. Test for positive signal lock.

Pin Descriptions

Pin NUMBER	PIN NAME	FUNCTION
1, 2, 16	PROG A, B, C	Digital inputs to select ÷ N value for internal counter. See Table 1 for values.
3	OSC/VCO OUT	Output of internal inverter/oscillator. Connect to external crystal or LC tank VCO circuit.
4	VDD (A)	Analog positive supply for oscillator, PLL circuits.
5	OSC/VCO IN	Input from external VCO.
6	VSS (A)	Analog ground for oscillator, PLL circuits.
7	CHARGE PUMP OUT	Connect to loop filter. If the H _{SYNC} phase is leading or H _{SYNC} frequency > CLK ÷ 2N, current is pumped into the filter capacitor to increase VCO frequency. If H _{SYNC} phase is lagging or frequency < CLK ÷ 2N, current is pumped out of the filter capacitor to decrease VCO frequency. During coast mode or when locked, charge pump goes to a high impedance state.
8	DIV SELECT	Divide select input. When high, the internal divider is enabled and EXT DIV becomes a test pin, outputting CLK ÷ 2N. When low, the internal divider is disabled and EXT DIV is an input from an external ÷N.
9	COAST	Three-state logic input. Low (< 1/3*V _{CC}) = normal mode, Hi Z (or 1/3 to 2/3*V _{CC}) = fast lock mode, High (> 2/3*V _{CC}) = coast mode.
10	HSYNC IN	Horizontal sync pulse (CMOS level) input.
11	VDD (D)	Positive supply for digital, I/O circuits.
12	LOCK DET	Lock detect output. Low level when PLL is locked. Pulses high when out of lock.
13	EXT DIV	External divide input when DIV SEL is low, internal ÷ 2N output when DIV SEL is high.
14	VSS (D)	Ground for digital, I/O circuits.
15	CLK OUT	Buffered output of the VCO.

TABLE 1. VCO DIVISORS

PROG A (PIN 16)	PROG B (PIN 1)	PROG C (PIN 2)	DIV VALUE (N)
0	0	0	1702
0	0	1	1728
0	1	0	1888
0	1	1	2270
1	0	0	1364
1	0	1	1716
1	1	0	1560
1	1	1	1820

Timing Diagrams

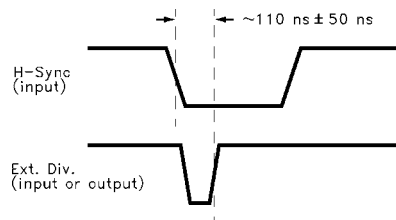

PLL LOCKED CONDITION (PHASE ERROR = 0)

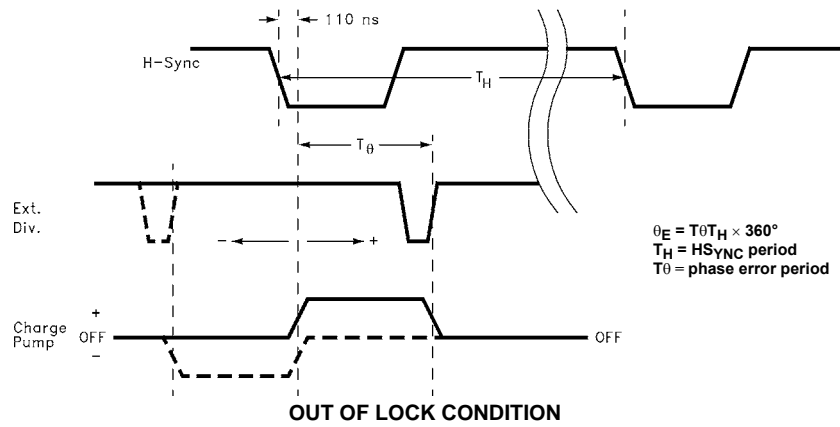

OUT OF LOCK CONDITION

Test Circuit

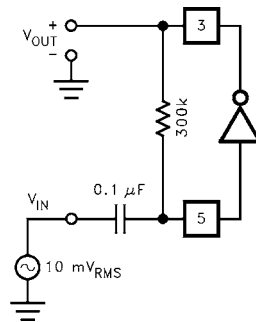

TEST CIRCUIT 1

Typical Performance Curves

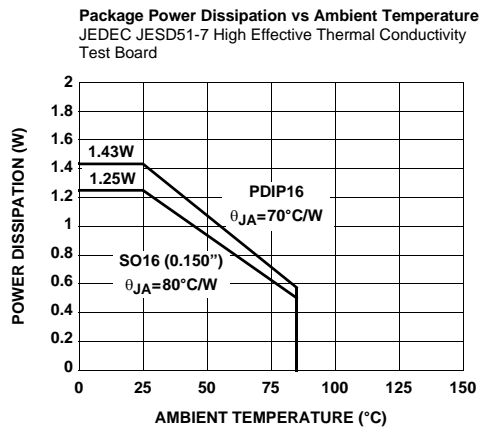
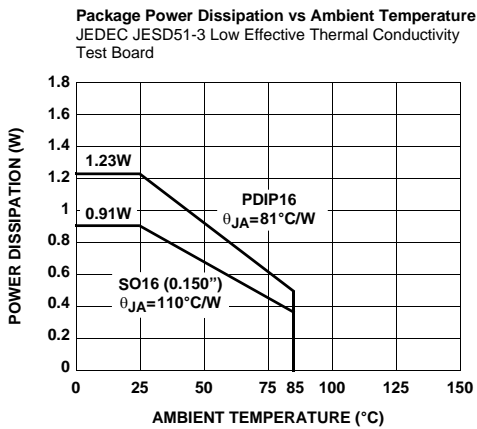
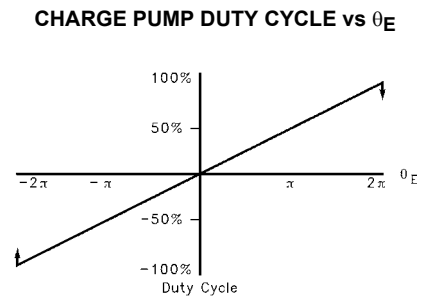
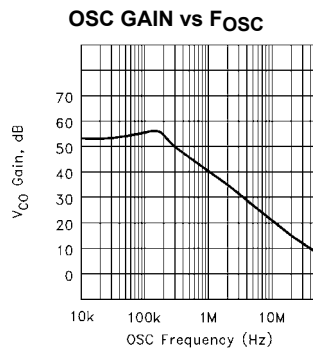
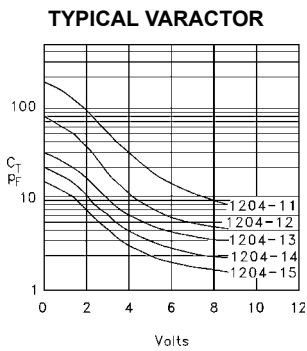
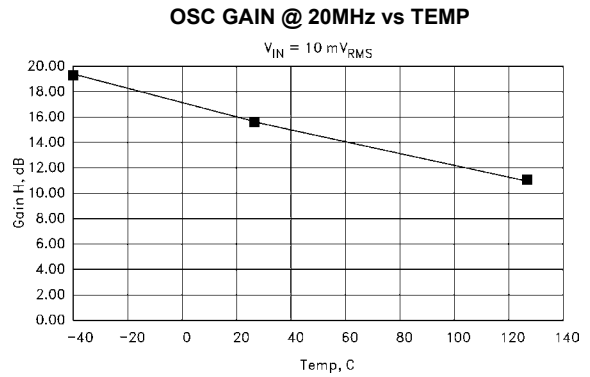
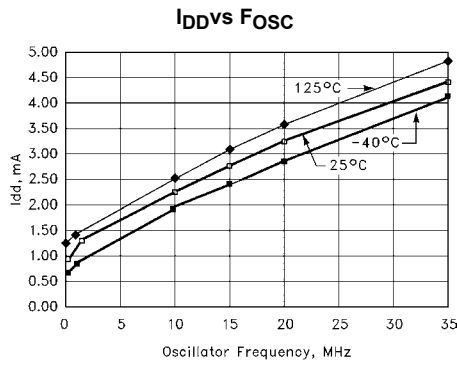

EL4585 Block Diagram

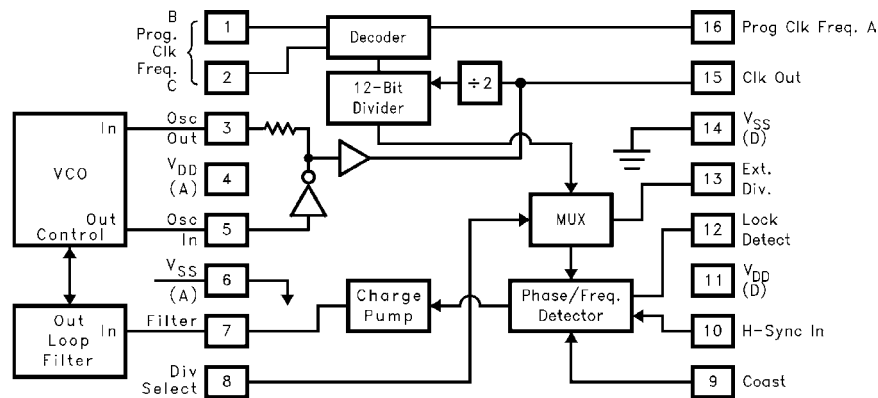

Description Of Operation

The horizontal sync signal (CMOS level, falling leading edge) is input to H_{SYNC} input (pin 10). This signal is delayed about 110ns, the falling edge of which becomes the reference to which the clock output will be locked. (See timing diagrams.) The clock is generated by the signal on pin 5, OSC IN. There are 2 general types of VCO that can be used with the EL4585, LC and crystal controlled. Additionally, each type can be either built up using discrete components, including a varactor as the frequency controlling element, or complete, self contained modules can be purchased with everything inside a metal can. These modules are very forgiving of PCB layout, but cost more than discrete solutions. The VCO or VCXO is used to regulate the clock. An LC tank resonator has greater "pull" than a crystal controlled circuit, but will also be more likely to drift over time, and thus will generate more jitter. The "pullability" of the circuit refers to the ability to pull the frequency of oscillation away from its center frequency by modulating the voltage on the control pin of the VCO module or varactor, and is a function of the slope and range of the capacitance-voltage curve of the varactor or VCO module used. The VCO signal is sent to the CLK out pin, divided by two, then sent to the divide by N counter. The divisor N is determined by the state of pins 1, 2, and 16 and is described in Table 1. The divided signal is sent, along with the delayed H_{SYNC} input, to the phase/frequency detector, which compares the two signals for phase and frequency differences. Any phase difference is converted to a current at the charge pump output, (pin 7). A VCO with a positive frequency deviation with control voltage must be used. Varactors have negative capacitance slope with voltage, resulting in positive frequency deviation with increasing control voltage for the oscillators in Figures 10 and 11.

VCO

The VCO should be tuned so that its frequency of oscillation is very close to the required clock output frequency when the voltage on the varactor is 2.5V. VCXO and VCO modules are already tuned to the desired frequency, so this step is not necessary if using one of these units. The output range of

the charge pump output (pin 7) is 0V to 5V, and it can source or sink a maximum of about 300 μ A, so all frequency control must be accomplished with variable capacitance from the varactor within this range. Crystal oscillators are more stable than LC oscillators, which translates into lower jitter, but LC oscillators can be pulled from their mid-point values further, resulting in a greater capture and locking range. If the incoming horizontal sync signal is known to be very stable, then a crystal oscillator circuit can be used. If the H_{SYNC} signal experiences frequency variations of greater than about 300ppm, an LC oscillator should be considered, as crystal oscillators are very difficult to pull this far. When H_{SYNC} input frequency is greater than CLK frequency \div 2N, charge pump output (pin 7) sources current into the filter capacitor, increasing the voltage across the varactor, thus tending to increase VCO frequency. Conversely, charge pump output pulls current from the filter capacitor when H_{SYNC} frequency is less than CLK \div 2N, forcing the VCO frequency lower.

Loop Filter

The loop filter controls how fast the VCO will respond to a change in phase comparator output stimulus. Its components should be chosen so that fast lock can be achieved, yet with a minimum of VCO "hunting", preferably in one to two oscillations of charge pump output, assuming the VCO frequency starts within capture range. If the filter is under-damped, the VCO will over and under-shoot the desired operating point many times before a stable lock takes place. It is possible to under-damp the filter so much that the loop itself oscillates, and VCO lock is never achieved. If the filter is over-damped, the VCO response time will be excessive and many cycles will be required for a lock condition. Over-damping is also characterized by an easily unlocked system because the filter can't respond fast enough to perturbations in VCO frequency. A severely over damped system will seem to endlessly oscillate, like a very large mass at the end of a long pendulum. Due to parasitic effects of PCB traces and component variables, it will take some trial and error experimentation to determine the best

values to use for any given situation. Use the component tables as a starting point, but be aware that deviations from these values are not out of the ordinary.

External Divide

DIV SEL (pin 8) controls the use of the internal divider. When high, the internal divider is enabled and EXT DIV (pin 13) outputs the CLK out divided by 2N. This is the signal to which the horizontal sync input will lock. When divide select is low, the internal divider output is disabled, and external divide becomes an input from an external divider, so that a divisor other than one of the 8 pre-programmed internal divisors can be used.

Normal Mode

Normal mode is enabled by pulling COAST (pin 9) low (below $1/3 \cdot V_{CC}$). If H_{SYNC} and CLK ÷ 2N have any phase or frequency difference, an error signal is generated and sent to the charge pump. The charge pump will either force current into or out of the filter capacitor in an attempt to modulate the VCO frequency. Modulation will continue until the phase and frequency of CLK ÷ 2N exactly match the H_{SYNC} input. When the phase and frequency match (with some offset in phase that is a function of the VCO characteristics), the error signal goes to zero, lock detect no longer pulses high, and the charge pump enters a high impedance state. The clock is now locked to the H_{SYNC} input. As long as phase and frequency differences remain small, the PLL can adjust the VCO to remain locked and lock detect remains low.

Fast Lock Mode

Fast Lock mode is enabled by either allowing coast to float, or pulling it to mid supply (between $1/3$ and $2/3 \cdot V_{CC}$). In this mode, lock is achieved much faster than in normal mode, but the clock divisor is modified on the fly to achieve this. If the phase detector detects an error of enough magnitude, the clock is either inhibited or reset to attempt a "fast lock" of the signals. Forcing the clock to be synchronized to the H_{SYNC} input this way allows a lock in approximately 2 H-cycles, but the clock spacing will not be regular during this time. Once the near lock condition is attained, charge pump output should be very close to its lock-on value, and placing the device into normal mode should result in a normal lock very quickly. Fast lock mode is intended to be used where H_{SYNC} becomes irregular, until a stable signal is again obtained.

Coast Mode

Coast mode is enabled by pulling COAST (pin 9) high (above $2/3 \cdot V_{CC}$). In coast mode the internal phase detector is disabled and filter out remains in high impedance mode to keep filter out voltage and VCO frequency as constant as possible. VCO frequency will drift as charge leaks from the filter capacitor, and the voltage changes the VCO operating point. Coast mode is intended to be used when noise or signal degradation result in loss of horizontal sync for many cycles. The phase detector will not attempt to adjust to the

resultant loss of signal so that when horizontal sync returns, sync lock can be re-established quickly. However, if much VCO drift has occurred, it may take as long to re-lock as when restarting.

Lock Detect

Lock detect (pin 12) will go low when lock is established. Any DC current path from charge pump out will skew EXT DIV relative to H_{SYNC} in, tending to offset or add to the 110ns internal delay, depending on which way the extra current is flowing. This offset is called static phase error, and is always present in any PLL system. If, when the part stabilizes in a locked mode, lock detect is not low, adding or subtracting from the loop filter series resistor R₂ will change this static phase error to allow LDET to go low while in lock. The goal is to put the rising edge of EXT DIV in sync with the falling edge of H_{SYNC} + 110ns. (See timing diagrams.) Increasing R₂ decreases phase error, while decreasing R₂ increases phase error. (Phase error is positive when EXT DIV lags H_{SYNC}.) The resistance needed will depend on VCO design or VCXO module selection.

Applications Information

Choosing External Components

1. To choose LC VCO components, first pick the desired operating frequency. For our example we will use 28.636MHz, with an H_{SYNC} frequency of 15.734kHz.
2. Choose a reasonable inductor value (1-5μH works well). We choose 3.3μH.
3. Calculate C_T needed to produce F_{OSC}.

$$F_{OSC} = \frac{1}{2\pi\sqrt{LC_T}}$$

$$C_T = \frac{1}{4\pi^2 F^2 L} = \frac{1}{4\pi^2 (28.636e6^2)(3.3e-6)} = 9.4pF$$

4. From the varactor data sheet find C_V @ 2.5V, the desired lock voltage. C_V=23pF for our SMV1204-12 for example.
5. C₂ should be about 10C_V, so we choose C₂=220pF for our example.
6. Calculate C₁. Since:

$$C_T = \frac{C_1 C_2 C_V}{(C_1 C_2) + (C_1 C_V) + (C_2 C_V)}$$

then:

$$C_1 = \frac{C_2 C_T C_V}{(C_2 C_V) - (C_2 C_T) - (C_T C_V)}$$

For our example, $C_1=17\text{pF}$. (A trim cap may be used for fine tuning.) Examples for each frequency using the internal divider follow.

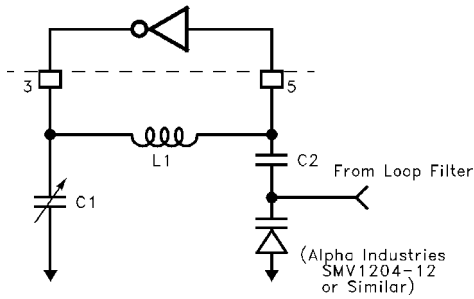

TYPICAL LC VCO

LC VCO COMPONENT VALUES (APPROXIMATE) (NOTE)

FREQUENCY (MHz)	L ₁ (μH)	C ₁ (pF)	C ₂ (pF)
26.602	3.3	22	220
27.0	3.3	21	220
29.5	2.7	22	220
35.468	2.2	16	220
21.476	4.7	26	220
24.546	3.9	22	220
28.636	3.3	17	220

NOTE: Use shielded inductors for optimum performance.

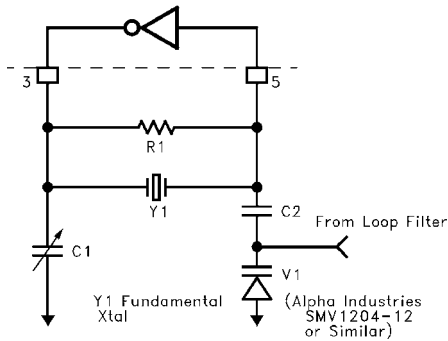

TYPICAL XTAL VCO

Typical Application

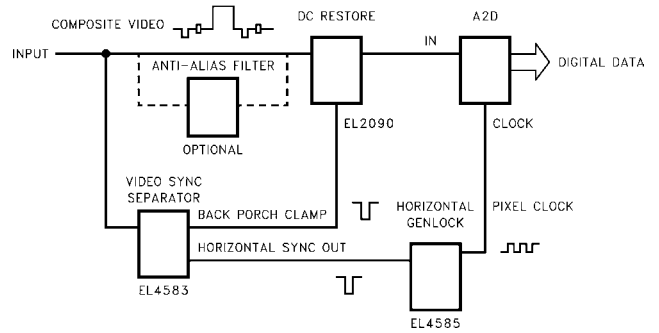

Horizontal genlock provides clock for an analog to digital converter, digitizing analog video.

XTAL VCO COMPONENT VALUES (APPROXIMATE)

FREQUENCY (MHz)	R ₁ (kΩ)	C ₁ (pF)	C ₂ (μF)
26.602	300	15	0.001
27.0	300	15	0.001
29.5	300	15	0.001
35.468	300	15	0.001
21.476	300	15	0.001
24.546	300	15	0.001
28.636	300	15	0.001

The above oscillators are arranged as Colpitts oscillators, and the structure is redrawn here to emphasize the split capacitance used in a Colpitts oscillator. It should be noted that this oscillator configuration is just one of literally hundreds possible, and the configuration shown here does not necessarily represent the best solution for all applications. Crystal manufacturers are very informative sources on the design and use of oscillators in a wide variety of applications, and the reader is encouraged to become familiar with them.

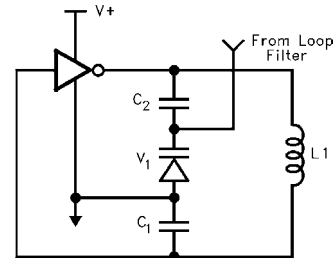

COLPITTS OSCILLATOR

C_1 is to adjust the center frequency, C_2 DC isolates the control from the oscillator, and V_1 is the primary control device. C_2 should be much larger than C_V so that V_1 has

maximum modulation capability. The frequency of oscillation is given by:

$$F = \frac{1}{2\pi\sqrt{LC_T}}$$

$$C_T = \frac{C_1 C_2 C_V}{(C_1 C_2) + (C_1 C_V) + (C_1 C_V)}$$

Choosing Loop Filter Components

The PLL, VCO, and loop filter can be described as:

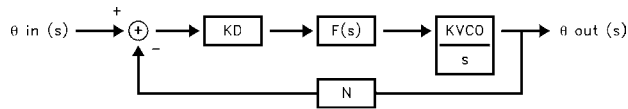

Where:

K_d = phase detector gain in A/rad

$F(s)$ = loop filter impedance in V/A

K_{VCO} = VCO gain in rad/s/V

N = Total internal or external divisor (see 3 below)

It can be shown that for the loop filter shown below:

$$C_3 = \frac{K_d K_{VCO}}{N\omega_n^2}, C_4 = \frac{C_3}{10}, R_3 = \frac{2N\zeta\omega_n}{K_d K_{VCO}}$$

Where ω_n = loop filter bandwidth, and ζ = loop filter damping factor.

1. $K_d = 300\mu A/2\pi rad = 4.77e-5 A/rad$ for the EL4585.
2. The loop bandwidth should be about H_{SYNC} frequency/20, and the damping ratio should be 1 for optimum performance. For our example, $\omega_n = 15.734kHz/20 = 787 Hz \approx 5000 rad/S$.
3. $N = 910 \times 2 = 1820$ from Table 1.

$$N = \frac{F_{VCO}}{F_{Hsync}} = \frac{28.636M}{15.73426k} = 1820 = 910 \times 2$$

4. K_{VCO} represents how much the VCO frequency changes for each volt applied at the control pin. It is assumed (but probably is not) linear about the lock point (2.5V). Its value depends on the VCO configuration and the varactor transfer function $C_V = F(V_C)$, where V_C is the reverse bias control voltage, and C_V is varactor capacitance. Since $F(V_C)$ is nonlinear, it is probably best to build the VCO and measure K_{VCO} about 2.5V. The results of one such measurement are shown below. The slope of the curve is determined by linear regression techniques and equals K_{VCO} . For our example, $K_{VCO} = 9.06 Mrad/s/V$.

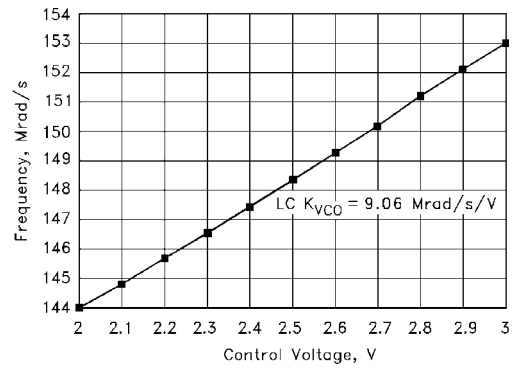

FOSC vs VC, LC VCO

5. Now we can solve for C_3 , C_4 , and R_3 :

$$C_3 = \frac{K_d K_{VCO}}{N\omega_n^2} = \frac{(4.77e-5)(9.06e6)}{(1820)(5000)^2} = 0.01\mu F$$

$$C_4 = \frac{C_3}{10} = 0.001\mu F$$

$$R_3 = \frac{2N\zeta\omega_n}{K_d K_{VCO}} = \frac{(2)(1820)(1)(5000)}{(4.77e-5)(9.06e6)} = 42.1k\Omega$$

We choose $R_3 = 43k\Omega$ for convenience.

6. Notice R_2 has little effect on the loop filter design. R_2 should be large, around 100K, and can be adjusted to compensate for any static phase error $T\theta$ at lock, but if made too large, will slow loop response. If R_2 is made smaller, $T\theta$ (see timing diagrams) increases, and if R_2 increases, $T\theta$ decreases. For LDET to be low at lock, $|T\theta| < 50ns$. C_4 is used mainly to attenuate high frequency noise from the charge pump. The effect these components have on time to lock is illustrated below.

Lock Time

Let $T = R_3 C_3$. As T increases, damping increases, but so does lock time. Decreasing T decreases damping and speeds up loop response, but increases overshoot and thus increases the number of hunting oscillations before lock. Critical damping ($\zeta=1$) occurs at minimum lock time. Because decreased damping also decreases loop stability, it is sometimes desirable to design slightly overdamped ($\zeta>1$), trading lock time for increased stability.

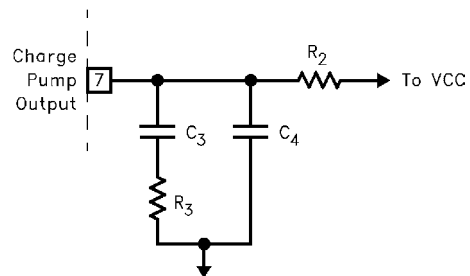

TYPICAL LOOP FILTER

LC LOOP FILTER COMPONENTS (APPROXIMATE)

FREQUENCY (MHz)	R ₂ (kΩ)	R ₃ (kΩ)	C ₃ (μF)	C ₄ (μF)
26.602	100	39	0.01	0.001
27.0	100	39	0.01	0.001
29.5	100	43	0.01	0.001
35.468	100	51	0.01	0.001
21.476	100	30	0.01	0.001
24.546	100	36	0.01	0.001
28.636	100	43	0.01	0.001

XTAL LOOP FILTER COMPONENTS (APPROXIMATE)

FREQUENCY (MHz)	R ₂ (kΩ)	R ₃ (MΩ)	C ₃ (pF)	C ₄ (pF)
26.602	100	4.3	68	6.8
27.0	100	4.3	68	6.8
29.5	100	4.3	68	6.8
35.468	100	4.3	68	6.8
21.476	100	4.3	68	6.8
24.546	100	4.3	68	6.8
28.636	100	4.3	68	6.8

PCB Layout Considerations

It is highly recommended that power and ground planes be used in layout. The oscillator and filter sections constitute a feedback loop and thus care must be taken to avoid any feedback signal influencing the oscillator except at the control input. The entire oscillator/filter section should be surrounded by copper ground to prevent unwanted influences from nearby signals. Use separate paths for analog and digital supplies, keeping the analog (oscillator section) as short and free from spurious signals as possible. Careful attention must be paid to correct bypassing. Keep lead lengths short and place bypass caps as close to the supply pins as possible. If laying out a PCB to use discrete components for the VCO section, care must be taken to avoid parasitic capacitance at the OSC pins 3 and 5, and FILTER out (pin 7). Remove ground and power plane copper above and below these traces to avoid making a capacitive connection to them. It is also recommended to enclose the oscillator section within a shielded cage to reduce external influences on the VCO, as they tend to be very sensitive to "hand waving" influences, the LC variety being more sensitive than crystal controlled oscillators. In general, the higher the operating frequency, the more important these considerations are. Self contained VCXO or VCO modules are already mounted in a shielding cage and therefore do not require as much consideration in layout. Many crystal manufacturers publish informative literature regarding use and layout of oscillators which should be helpful.

EL4585/4 Demo Board

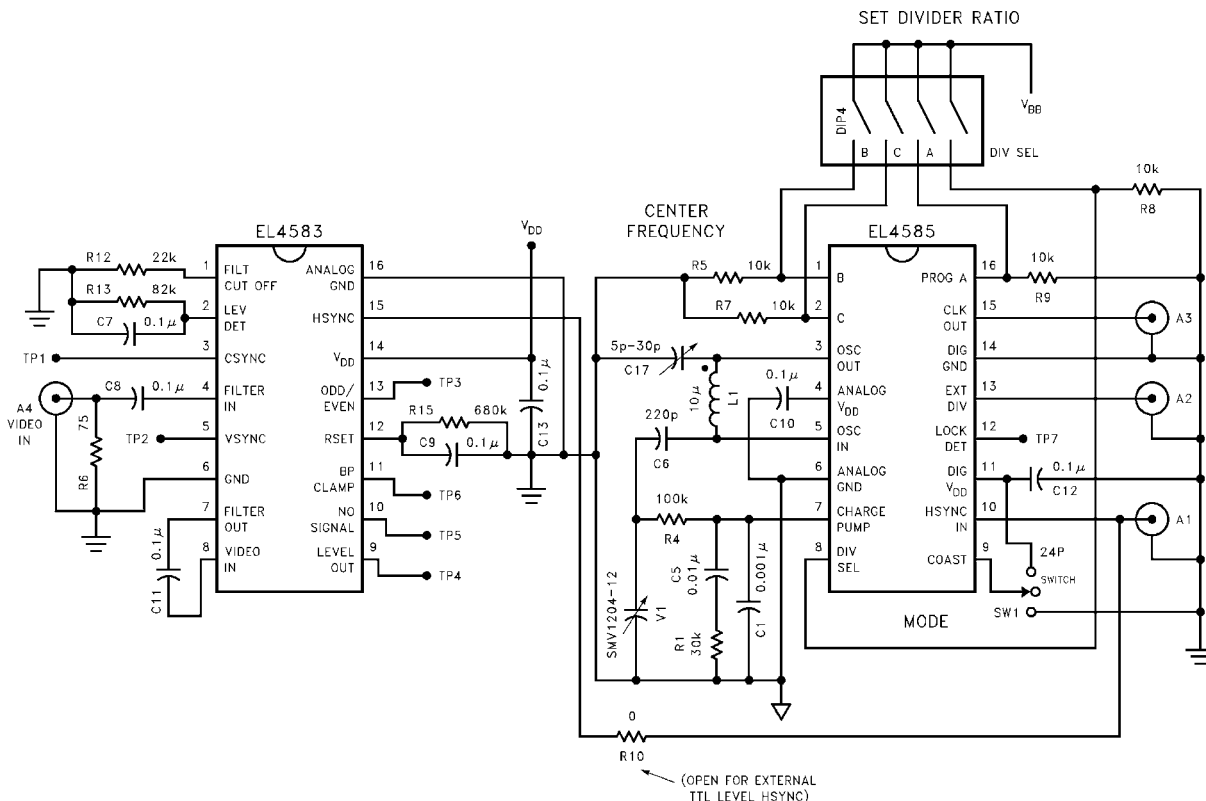

The VCO and loop filter section of the EL4583/4/5 Demo Board can be implemented in the following configurations:

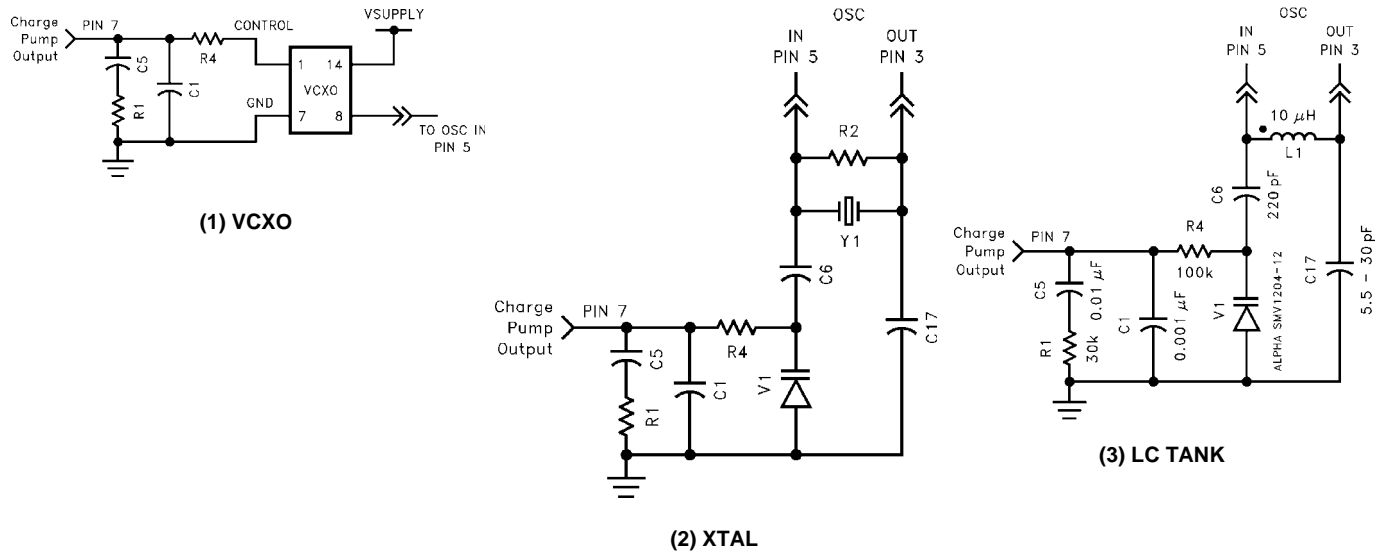

Component Sources

Inductors

- Dale Electronics
E. Highway 50
PO Box 180
Yankton, SD 57078-0180
(605) 665-9301

Crystals, VCXO, VCO Modules

- Connor-Winfield
2111 Comprehensive Drive
Aurora, IL 60606
(708) 851-4722
- Piezo Systems
100 K Street
PO Box 619
Carlisle, PA 17013
(717) 249-2151
- Reeves-Hoffman
400 West North Street
Carlisle, PA 17013
(717) 243-5929

- SaRonix
151 Laura Lane
Palo Alto, CA 94043
(415) 856-6900
- Standard Crystal
9940 Baldwin Place
El Monte, CA 91731
(818) 443-2121

Varactors

- Sky Works Solutions Inc.
20 Sylvan Road
Woburn, MA 01801
(781) 376-3000
www.skyworksinc.com
- Motorola Semiconductor Products
2100 E. Elliot
Tempe, AZ 85284
(602) 244-6900

Note: These sources are provided for information purposes only. No endorsement of these companies is implied by this listing.

All Intersil U.S. products are manufactured, assembled and tested utilizing ISO9000 quality systems. Intersil Corporation's quality certifications can be viewed at www.intersil.com/design/quality

Intersil products are sold by description only. Intersil Corporation reserves the right to make changes in circuit design, software and/or specifications at any time without notice. Accordingly, the reader is cautioned to verify that data sheets are current before placing orders. Information furnished by Intersil is believed to be accurate and reliable. However, no responsibility is assumed by Intersil or its subsidiaries for its use; nor for any infringements of patents or other rights of third parties which may result from its use. No license is granted by implication or otherwise under any patent or patent rights of Intersil or its subsidiaries.

For information regarding Intersil Corporation and its products, see www.intersil.com