

SP2T

## FEATURES

- DC - 2000 MHz
- < 2 mA, ±5 VDC
- 27 nSec Transition Time
- Ultra Small TO-5 Package
- Non-Reflective
- TTL Driver
- See DS0850-T For Driverless Version
- Low Cost



# MODEL NO. DS0813-T

## GaAs SP2T

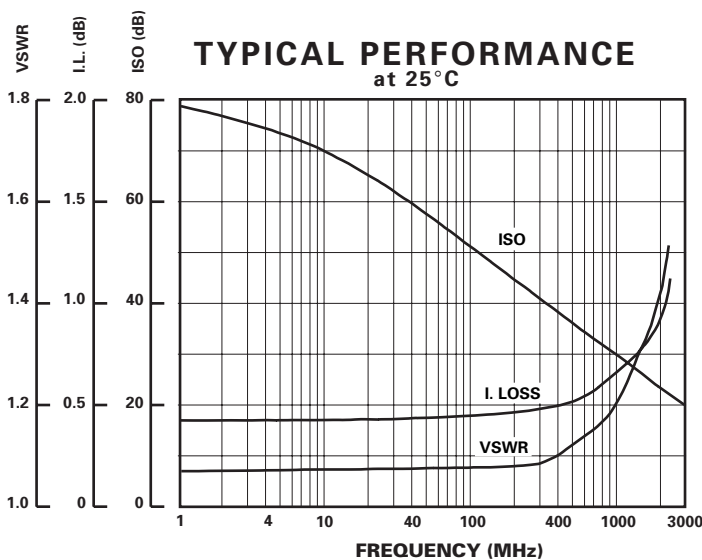
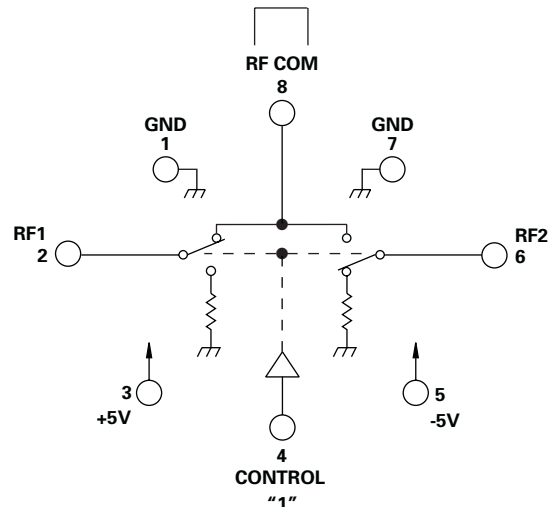
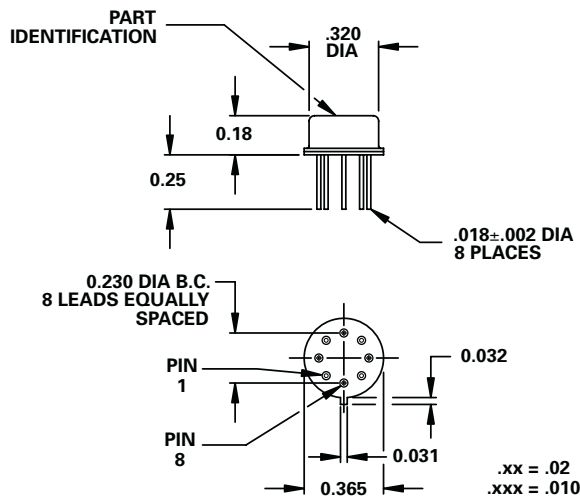

## GUARANTEED PERFORMANCE

Parameter	Min	Typ	Max	Units	Conditions
Operating Frequency	DC		2000	MHz	
DC Current		2	4	mA	At +5 VDC Supply
		1	2	mA	At -5 VDC Supply
Control Type		TTL			1 Line Logic "0" = RF Com to RF 2 Logic "1" = RF Com to RF 1
Control Current	High	1	±40	µA	VIH = +2.7V
	Low	1	±40	µA	VIL = +0.5V
Insertion Loss		0.7	0.9	dB	DC - 500 MHz
		0.9	1.2	dB	500 - 2000 MHz
Isolation	40	50		dB	DC - 100 MHz
	30	36		dB	100 - 500 MHz
	20	24		dB	500 - 2000 MHz
VSWR	Thru	1.1/1	1.3/1		DC - 500 MHz
		1.5/1	1.7/1		500 - 2000 MHz
	Termination	1.1/1	1.3/1		DC - 500 MHz
		1.5/1	1.7/1		500 - 2000 MHz
Impedance		50		OHMS	
Switching Speed		65	150	nSEC	50% TTL to 90% / 10% RF
Transition (Rise/Fall) Time		27		nSEC	90% / 10% or 10% / 90% RF
Switching (Video) Transients		8		mV	Peak Value
Intercept Points	2nd	+85		dBm	214 MHz / 127 MHz
	3rd	+47		dBm	107 MHz / 127 MHz
RF Power	Operate	+12	+10	dBm	0.1 dB Comp. Above 20 MHz
	No Damage		+30	dBm	
Operating Temperature	-55	+25	+125	°C	TA