

TinySwitch-III[®]

9.65 W, Dual Output Power Supply for Residential Heating Control

Application	Device	Power Output	Input Voltage	Output Voltage	Topology
Residential Heating Control	TNY275P	9.65 W	185-265 VAC	5V / 0.25 A, 24 V / 0.35 A	Flyback

Design Highlights

- Simple, low cost design only requires 38 parts
- <150 mW no-load consumption at 230 VAC input
- Meets CEC / ENERGY STAR active-mode efficiency and no-load input power requirements
- Both outputs exhibit good cross regulation
- Meets CISPR-22 Class B/EN55022 B without input X or Y capacitors or an input common mode choke

Operation

The flyback converter shown in Figure 1 uses a TNY275 (U1) to provide two output voltages: 5 V at 250 mA and 24 V at 350 mA. Typical applications are residential heating controllers (furnace) or any application where 2 outputs are required. The 9.65 W of output power is delivered by using the increased current limit of U1, which is selected by the value of C11.

The MOSFET integrated within U1 switches the primary of transformer T1. Each time it turns on, the primary current ramps until it reaches an internal current limit and the

MOSFET is turned off. Then the energy stored in T1 transfers to the secondary where it is rectified and filtered by D1 and C2 and D4 and C5. The primary side RCD clamp (D8, C4 R1 and R8) limits the peak DRAIN voltage spike caused by transformer leakage inductance.

Power Integrations *E-Shield*[™] transformer construction techniques, the RCD clamp, a snubber (R11 and C14), a simple π filter (C7, C8, L1 and L5) and the frequency jitter function of the *TinySwitch-III* family, provide good EMI margin, even with the output return connected to safety earth ground (see Figure 3).

Key Design Points

- The turns ratio of the two secondary winding was optimized for output voltage centering.
- The use of a fast instead of an ultrafast diode for D8 improves efficiency by recovering some leakage inductance energy.

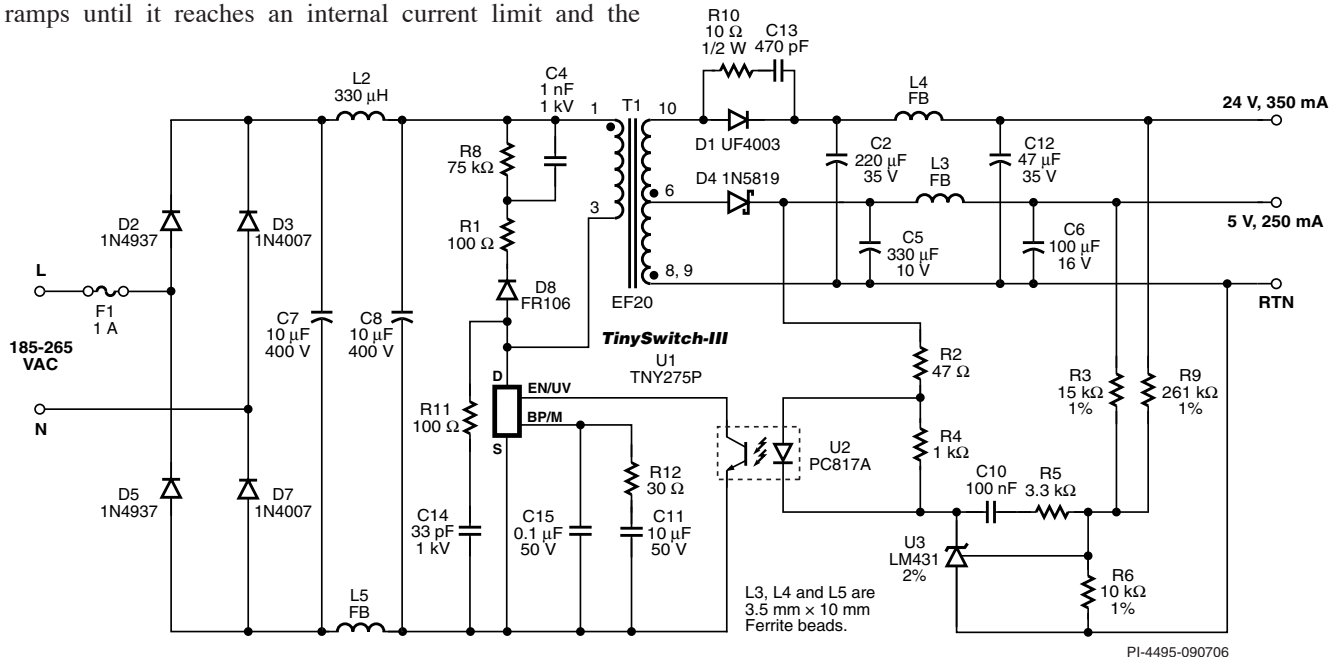

Figure 1. TinySwitch-III 9.65 W Residential Heating Controller Power Supply.

PI-4495-090706

- Maximize the value of R8 and minimize the value of C4 for the lowest no-load consumption. However, verify that the peak drain voltage is <650 V at high line, under maximum overload conditions.
- Select transformer wire gauge sizes so that each winding layer occupies the full bobbin width. This lowers leakage inductance and improves output cross regulation.
- Use option to add *E-Shield* windings in *PI Transformer Designer* software to reduce conducted EMI noise generation.
- To lower the no-load power consumption even further, use an optional bias supply circuit to feed the rated data sheet current (through a series resistor) to the BP/M pin of U1.

Output (V)	Load Range (mA)	Regulation (%)								
		-2	-1.5	-1	-0.5	0	0.5	1	1.5	2
5	50-250									
24	88-350									

Table 1. Worst Case Output Cross Regulation at 185 VAC Output Loads Varied as Shown and Maximum Deviation Recorded.

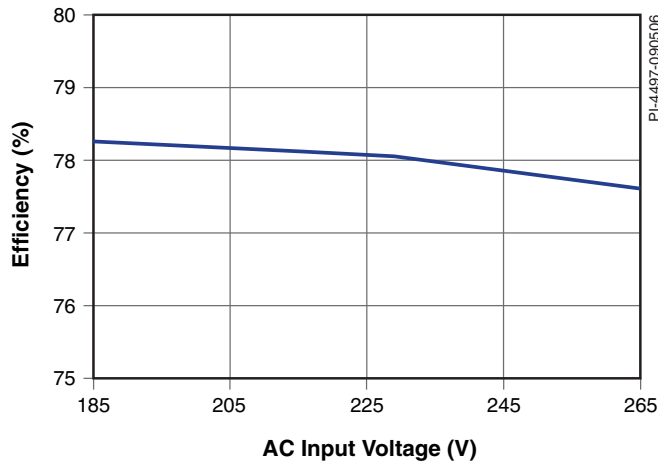

Figure 2. Full Load Efficiency vs Input Voltage.

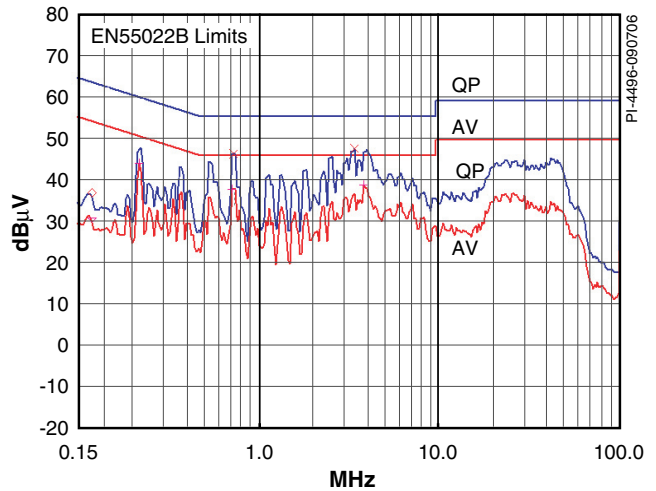

Figure 3. Worst Case Conducted EMI at 230 VAC, Full Load Output Return Grounded.

TRANSFORMER PARAMETERS	
Core Material	EF20 TDK PC40, or equivalent A_{LG} of 323 nH/T ²
Bobbin	EF20, 10 pin (5+5), horizontal Pin Shine P-2015 or equivalent
Winding Details	Shield: 15T, 2 × 31 AWG Primary: 36T + 35T, 33 AWG Shield: 4T, 5 × 29 AWG 5 V: 3T, 4 × 26 AWG T.I.W. 24 V: 11T, 26 AWG T.I.W. (4 × 26 AWG = quadfilar 26 AWG)
Winding Order (Pin Numbers)	Apply 2 mm tape margin to both sides of bobbin Shield (1-NC), tape, Primary (3-1), Shield (NC-1), 5 V (6-8), 24 V (10-6)
Inductance	Primary: 1.62 mH ±5% Leakage: 50 µH maximum
Primary Resonant Frequency	800 kHz (minimum)

Table 2. Transformer Construction Information.

TIW = Triple Insulated Wire, NC = No Connect

For the latest updates, visit www.powerint.com

Power Integrations reserves the right to make changes to its products at any time to improve reliability or manufacturability. Power Integrations does not assume any liability arising from the use of any device or circuit described herein. POWER INTEGRATIONS MAKES NO WARRANTY HEREIN AND SPECIFICALLY DISCLAIMS ALL WARRANTIES INCLUDING, WITHOUT LIMITATION, THE IMPLIED WARRANTIES OF MERCHANTABILITY, FITNESS FOR A PARTICULAR PURPOSE, AND NON-INFRINGEMENT OF THIRD PARTY RIGHTS. The products and applications illustrated herein (transformer construction and circuits external to the products) may be covered by one or more U.S. and foreign patents or potentially by pending U.S. and foreign patent applications assigned to Power Integrations. A complete list of Power Integrations' patents may be found at www.powerint.com. Power Integrations grants its customers a license under certain patent rights as set forth at <http://www.powerint.com/ip.htm>.

The PI logo, **TOPSwitch**, **TinySwitch**, **LinkSwitch**, **DPA-Switch**, **PeakSwitch**, **EcoSmart**, **Clampless**, **E-Shield**, **Filterfuse**, **StackFET**, **PI Expert** and **PI FACTS** are trademarks of Power Integrations, Inc. Other trademarks are property of their respective companies. ©Copyright 2006, Power Integrations, Inc.

Power Integrations
5245 Hellyer Avenue
San Jose, CA 95138
Phone: 1-408-414-9200
Apps: 1-408-414-9660
Apps Fax: 1-408-414-9760

For a complete listing of worldwide sales offices, please visit www.powerint.com