



General Description

The DE-ACCM3D is a complete 3D ±3g analog accelerometer solution. It features integrated op amp buffers for direct connection to a microcontroller’s analog inputs, or for driving heavier loads.

The onboard 3.3V regulator and decoupling capacitor give you great flexibility when powering the device, and can also be bypassed for operation down to 2.0V.

The DE-ACCM3D is designed to fit the DIP-16 form factor, making it suitable for breadboarding, perfboarding, and insertion into standard chip sockets.

It is based on the Analog Devices ADXL330 for superior sensitivity and tighter accuracy tolerances.

Features

- Triple axis ±3g sense range
- Up to 360mV/g sensitivity
- 500Hz bandwidth
- Operating voltage 3.5V to 15V (onboard regulator)
- Operating voltage 2.0V to 3.6V (without regulator)
- 3.3V regulator can power external microcontroller
- Reverse voltage protection
- Output short protected
- Standard DIP-16 form factor
- Integrated power supply decoupling
- Draws 0.9mA
- Can accurately drive 500Ω loads

Applications

- Motion, tilt and slope measurement
- Device positioning
- Shock sensing
- Vehicle acceleration logging

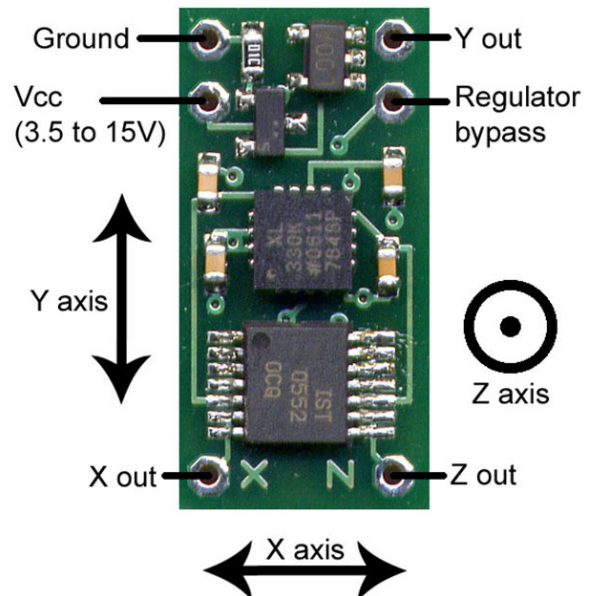
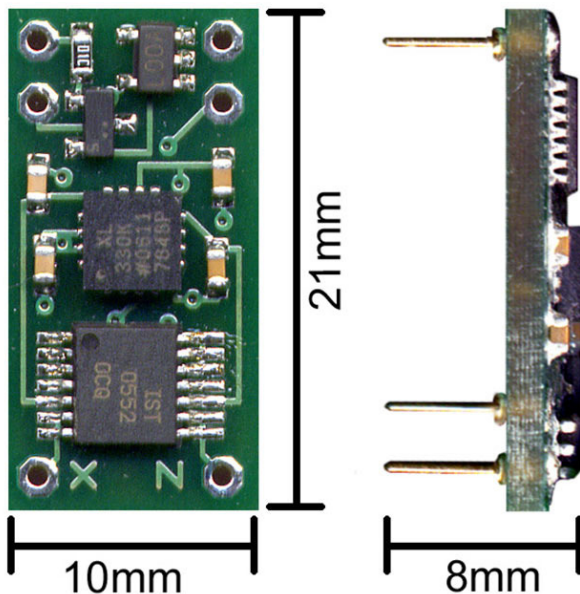

Measuring acceleration and tilt

(Using onboard 3.3V supply)

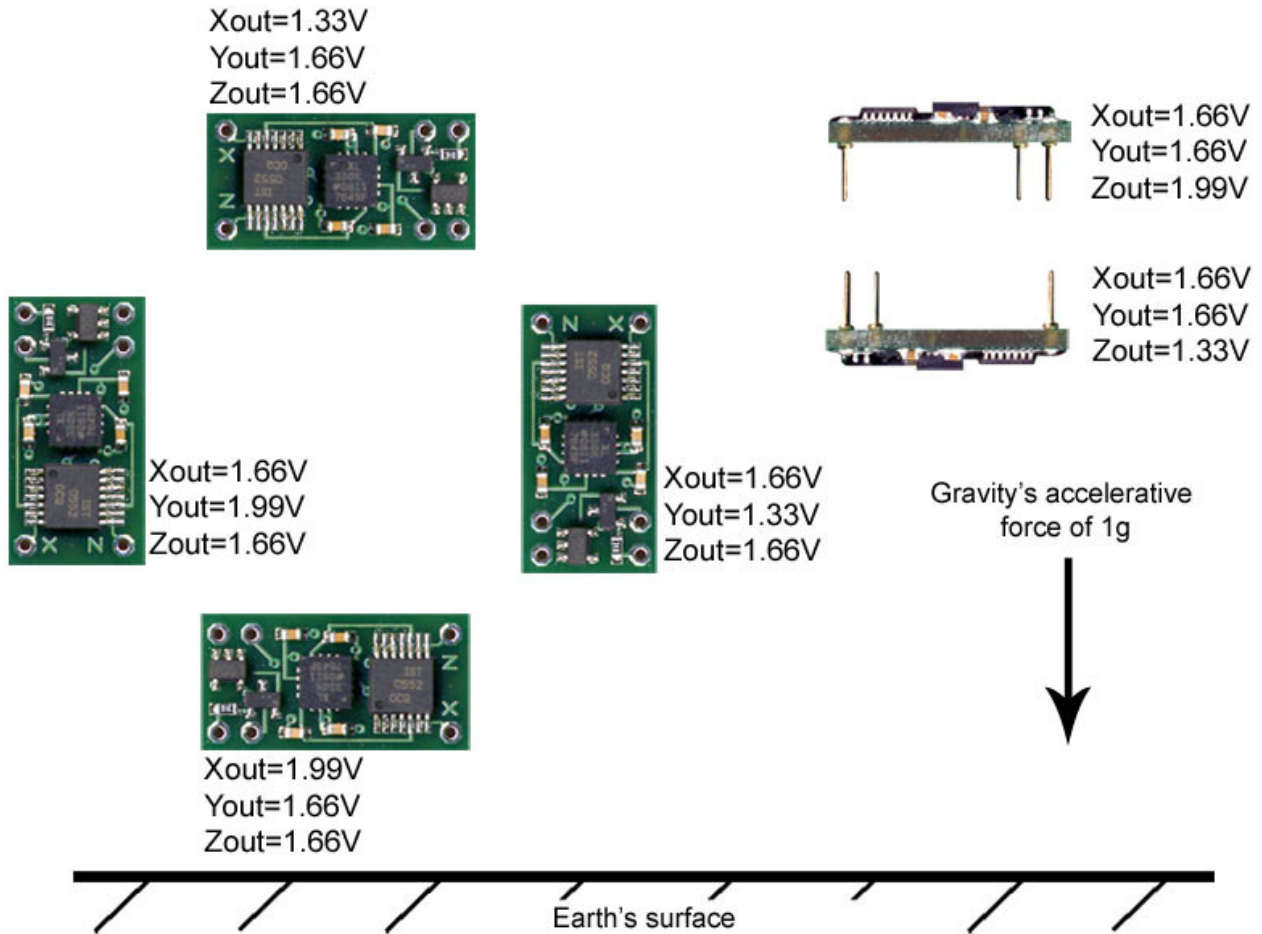

The voltage outputs on the DE-ACCM3D correspond to acceleration being experienced in the X, Y and Z directions. The output is ratiometric, so the output sensitivity (in mV/g) will depend on the supply voltage.

Sensitivity and accuracy

Here are some typical sensitivity values for common operating voltages:

Operating voltage	Sensitivity
3.6V	360 mV/g
3.33V (default when using onboard regulator)	333 mV/g
3.0V	300 mV/g
2.0V	195 mV/g

Due to manufacturing variances when Analog Devices makes their accelerometer chips, these values aren't always set in stone. Sensitivity can vary by up to 10% in extreme cases, and the 0g bias point can vary up to 5% on the X and Y axes, and 10% on the Z axis. For projects that require a very high degree of accuracy, we recommend that you incorporate measured calibrations into your hardware/software.

Example calculations

Voltage to acceleration example:

"With the 3.3V supply, the X output reads 2.06V. What acceleration does this correspond to?"

At 3.3V, the 0g point is approximately 1.66V

$2.06V - 1.66V = +0.40V$ with respect to the 0g point

At 3.3V, if sensitivity is 333mV/g, $0.40 / 0.333 = 1.20g$

Therefore the acceleration in the X direction is +1.20g

Acceleration to voltage example:

"I am powering the DE-ACCM3D with 2.0V. What voltage will correspond to an acceleration of -0.5g?"

At 2V, the 0g point is approximately 1.00V

If sensitivity at 2V is 195mV/g, $-0.5 * 0.195 = -0.0975V$ with respect to the 0g point.

$1.00V - 0.0975V = 0.903V$

Therefore you can expect a voltage of approximately 0.903V when experiencing an acceleration of -0.5g.

Voltage to tilt example:

"With a Vcc of 3.0V, and the accelerometer oriented flat and parallel to ground in my robot, Yout is 1.50V.

When my robot goes uphill, Yout increases to 1.67V. What is the slope of the hill?"

$1.67V - 1.50 = +0.17V$ with respect to the 0g point.

With a sensitivity of 300mV/g, $0.17 / 0.300 = 0.567g$

$\sin^{-1}(0.567) = 34.5^\circ$

The slope of the hill is 34.5° in the Y axis

Tilt to voltage example:

"I am making an antitheft device that will sound an alarm if it is tilted more than 10° with respect to ground in any direction. I have measured the 0g bias point to be 1.701V, and I want to know what voltage to trigger the alarm at. I am using the onboard 3.3V source."

$\sin(10^\circ) = 0.1736$ so acceleration with a tilt of 10° will be 0.1736g

$0.1736g * 0.333V/g = 0.058V$ with respect to the 0g point

$1.701 + 0.058 = 1.759V$

$1.701 - 0.058 = 1.643V$

Sound the alarm when the voltage reaches more than 1.759V or less than 1.643V.

Performance features

Output buffers

A bare accelerometer chip has an output impedance of $32\text{k}\Omega$, which is unsuitable for obtaining reliable measurements when connected to an analog to digital converter. On the DE-ACCM3D, a quad rail to rail operational amplifier buffers the outputs from the ADXL330, greatly reducing output impedance. The absolute maximum load beyond which accuracy begins to seriously suffer is 3.3mA , or 500Ω .

Supply filtering

A $1\mu\text{F}$ ceramic bypass capacitor on the DE-ACCM3D provides excellent power supply decoupling. No external capacitors are necessary between V_{cc} and GND.

Output filtering and noise

A pair of 10nF capacitors limit the noise figure of the DE-ACCM3D, without overly sacrificing bandwidth. RMS noise is typically 7.3mg , and output bandwidth is 500Hz - making it suitable for high frequency sampling of acceleration.

Regulator Bypass

Most people will want to power DE-ACCM3D using the onboard 3.3V regulator. However, if you are designing an application that needs a lower operating voltage, you can bypass the voltage regulator. To do this, use the GND pin as normal. For the positive supply, solder a wire to the exposed pad labeled **BYP**. The onboard $1\mu\text{F}$ capacitor will still be in parallel with the accelerometer chip, so additional capacitance is not necessary unless running from a noisy source.

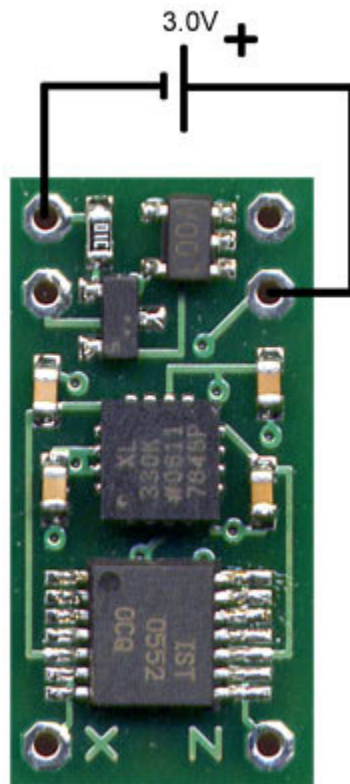

This would be useful for e.g. an application powered directly by 2 AA batteries or a lithium coin battery. The minimum operating voltage when using bypass mode is 2.0V and **the absolute maximum voltage that can be applied when bypassing the regulator is 3.6V .**

Powering external devices

It is possible to use the DE-ACCM3D's voltage regulator to power external devices that require 3.3V, such as a low voltage microcontroller. These devices must be extremely low power so as to not overload the regulator! The maximum current that can be drawn in this way is 50mA, but ideally you should try keep things below 10mA. This diagram shows how to connect up an example microcontroller and all 3 axes.

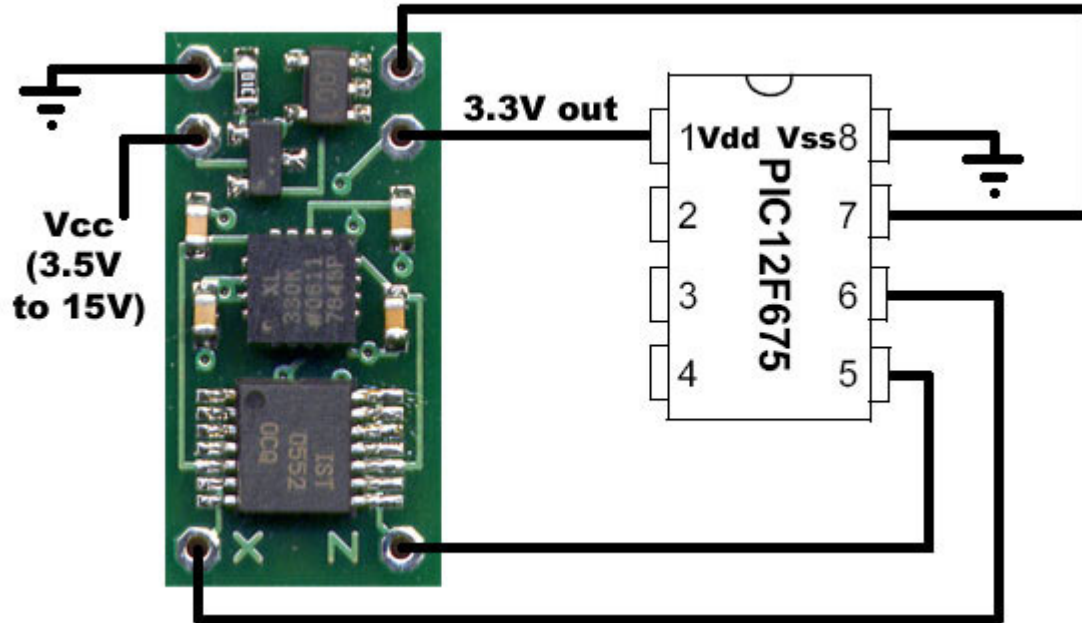

Additional capacitance across the microcontroller's power pins may be necessary, depending on your particular setup.

Protection features

Reverse voltage

In the event that you mix up VCC and GND, a P channel MOSFET will prevent current from flowing – protecting the DE-ACCM3D from damage. This protection is only designed to work with DC voltages. Do not apply AC voltages to the power pins.

Output shorting

The operational amplifier driving the DE-ACCM3D's outputs is capable of handling a direct short from the X, Y and Z outputs to ground for as long as you want.