

Features

- 0805 size
- Magnetic shielding
- Height as low as 0.85 mm
- Nickel barrier
- Lead free

Applications

- Prevention of electromagnetic interference to signals on the secondary side of electronic equipment

CV201210 Series - Ferrite Multi-Layer Chip Inductors

Electrical Specifications

Bourns Part No.	Inductance		Q	Test Freq.	SRF MHz	DCR	I rms
	μH	Tol. %					
CV201210-47NK	0.047	± 10	15	50*	320	200	300
CV201210-68NK	0.068	± 10	15	50	280	200	300
CV201210-82NK	0.082	± 10	15	50	255	200	300
CV201210-R10K	0.10	± 10	20	25	235	300	250
CV201210-R12K	0.12	± 10	20	25	220	300	250
CV201210-R15K	0.15	± 10	20	25	200	400	250
CV201210-R18K	0.18	± 10	20	25	185	400	250
CV201210-R22K	0.22	± 10	20	25	170	500	250
CV201210-R27K	0.27	± 10	20	25	150	500	250
CV201210-R33K	0.33	± 10	20	25	145	550	250
CV201210-R39K	0.39	± 10	25	25	135	650	200
CV201210-R47K	0.47	± 10	25	25	125	650	200
CV201210-R56K	0.56	± 10	25	25	115	750	150
CV201210-R68K	0.68	± 10	25	25	105	800	150
CV201210-R82K	0.82	± 10	25	25	100	1000	150
CV201210-1R0K	1.0	± 10	45	10	75	400	50
CV201210-1R2K	1.2	± 10	45	10	65	500	50
CV201210-1R5K	1.5	± 10	45	10	60	500	50
CV201210-1R8K	1.8	± 10	45	10	55	600	50
CV201210-2R2K	2.2	± 10	45	10	50	650	30
CV201210-2R7K	2.7	± 10	45	10	45	750	30
CV201210-3R3K	3.3	± 10	45	10	41	800	30
CV201210-3R9K	3.9	± 10	45	10	38	900	30
CV201210-4R7K	4.7	± 10	45	10	35	1000	30
CV201210-5R6K	5.6	± 10	45	4	32	900	15
CV201210-6R8K	6.8	± 10	45	4	29	1000	15
CV201210-8R2K	8.2	± 10	45	4	26	1100	15
CV201210-100K	10	± 10	45	2	24	1150	15
CV201210-120K	12	± 10	45	2	22	1250	5
CV201210-150K	15	± 10	30	1	19	800	5
CV201210-180K	18	± 10	30	1	18	900	5
CV201210-220K	22	± 10	30	1	16	1100	5
CV201210-270K	27	± 10	30	1	14	1150	5
CV201210-330K	33	± 10	30	0.4	13	1250	5

General Specifications

Temperature Rise30 °C max. at rated current
 Operating Temperature-55 °C to +125 °C
 Storage Temperature-55 °C to +125 °C
 Reflow Soldering ...230 °C, 50 sec. max.
 Resistance to Soldering Heat260 °C, 10 seconds

Materials

Base MaterialFerrite
 Terminal.....Ag/Ni/Sn
 Packaging:
 0.85 mm product height4,000 pcs. per reel
 1.25 mm product height2,000 pcs. per reel

Product Dimensions

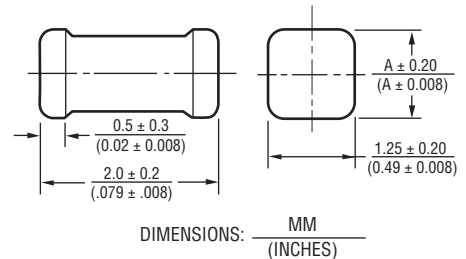

Model	Dimension A
CV201210-47NK through CV201210-R39K	$\frac{0.85}{(0.033)}$
CV201210-R47K through CV201210-R82K	$\frac{1.25}{(0.050)}$
CV201210-1R0K through CV201210-2R2K	$\frac{0.85}{(0.033)}$
CV201210-2R7K through CV201210-330K	$\frac{1.25}{(0.050)}$

*Test Frequency for L (inductance) of CV201210-47NK is 10 MHz.

Packaging Specifications

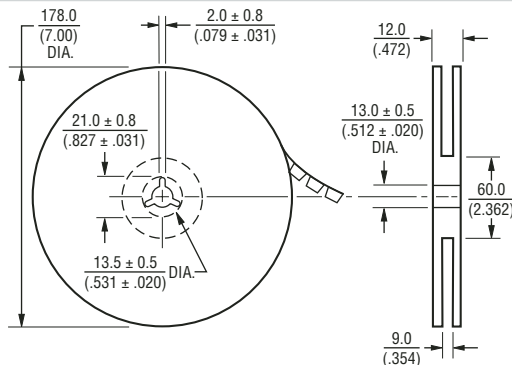

Recommended Layout

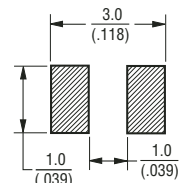

*RoHS Directive 2002/95/EC Jan 27 2003 including Annex
 Specifications are subject to change without notice.
 Customers should verify actual device performance in their specific applications.

CV201210 Series - Ferrite Multi-Layer Chip Inductors

BOURNS®

Electrical Specifications

Q Characteristics

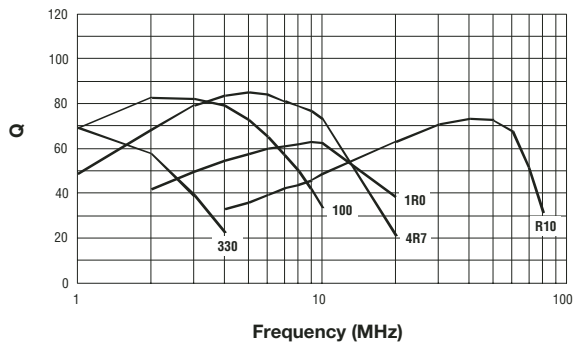

DC Bias Characteristics

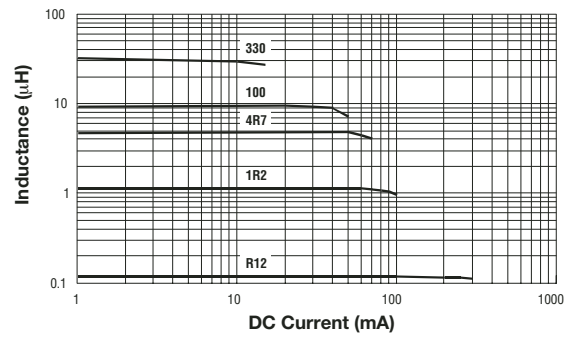

Inductance Characteristics

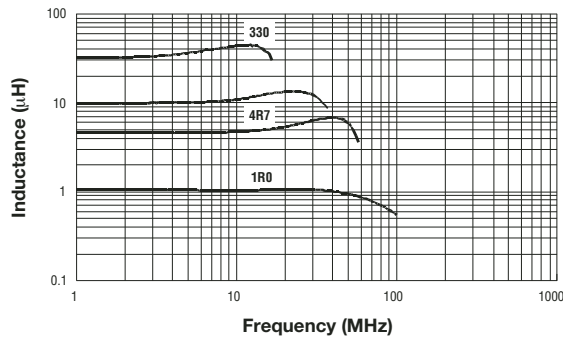

Impedance Characteristics

