

## 20-30GHz High Power Amplifier

### GaAs Monolithic Microwave IC

*preliminary*

#### Description

The CHA4092 is a high gain broadband three-stage balanced monolithic power amplifier. It is designed for a wide range of applications, from military to commercial communication systems.

The circuit is manufactured with a PM-HEMT process, 0.25 $\mu$ m gate length, via holes through the substrate, air bridges and electron beam gate lithography.

It is available in chip form.

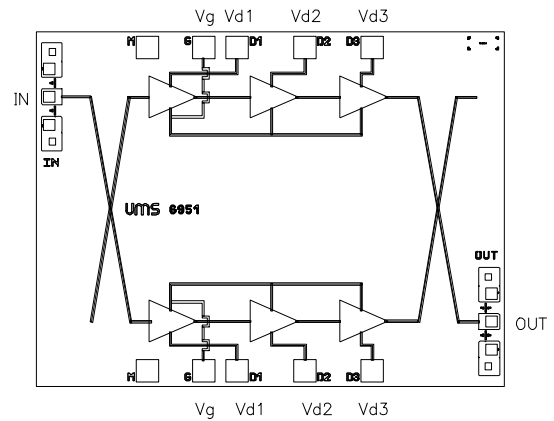

#### Main Features

- ▮ Broadband performances : 20-30GHz
- ▮ 22 dBm output power ( 1dB gain comp. )
- ▮ 17 dB  $\pm$  1.5 dB gain
- ▮ Chip size : 1.65 X 2.15 X 0.10 mm

Typical on wafer measurements :

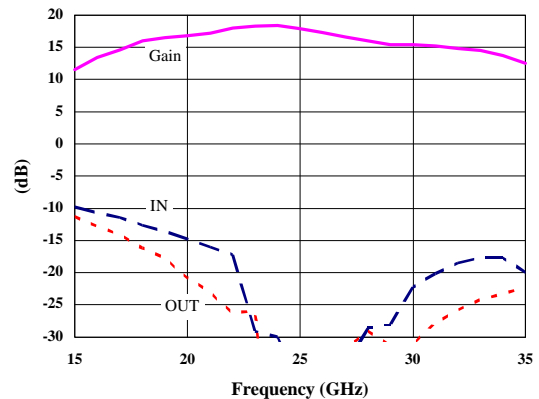

#### Main Characteristics

Tamb. = 25°C

Symbol	Parameter	Min	Typ	Max	Unit
Fop	Operating frequency range	20		30	GHz
G	Small signal gain	16	17		dB
P1dB	Output power at 1dB gain compression		22		dBm
Id	Bias current		700	900	mA

ESD Protection : Electrostatic discharge sensitive device. Observe handling precautions !

## Electrical Characteristics for Broadband Operation

Tamb = +25°C, Vd1,2,3 = 3.5Volts

Symbol	Parameter	Min	Typ	Max	Unit
Fop	Operating frequency range (1)	20		30	GHz
G	Small signal gain (1) (2)	16	17		dB
ΔG	Small signal gain flatness (1) (2)		± 1.5		dB
Is	Reverse isolation (1)		30		dB
P1db	Pulsed Output power at 1dB gain compression (1)		22		dBm
VSWRin	Input VSWR (1)			2.0:1	
VSWRout	Output VSWR (1)			2.0:1	
Id	Bias current		700	900	mA

(1) These values are representative of on-wafer measurements that are made without bonding wires at the RF ports. In the case of a jig or a module CW mode operation, the typical output power may be around 2dB less.

(2) Vd1,2,3 = 2Volts

## Absolute Maximum Ratings

Tamb. = 25°C (1)

Symbol	Parameter	Values	Unit
Vd	Drain bias voltage	4	V
Id	Drain bias current	1200	mA
Vg	Gate bias voltage	-2 to +0.4	V
Ta	Operating temperature range	-40 to +85	°C
Tstg	Storage temperature range	-55 to +155	°C

(1) Operation of this device above any one of these parameters may cause permanent damage.

Bias Conditions :  $T_{amb} = +25^{\circ}\text{C}$ ,  $V_d = 3.5\text{Volt}$ ,  $V_g = -0.2\text{Volt}$ .

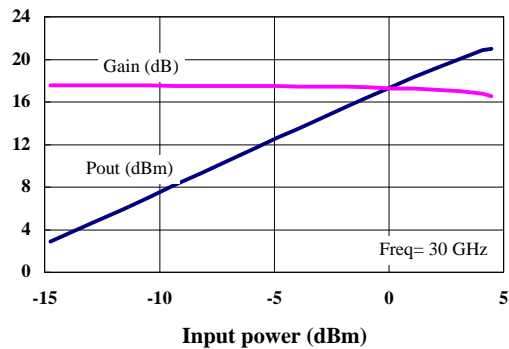
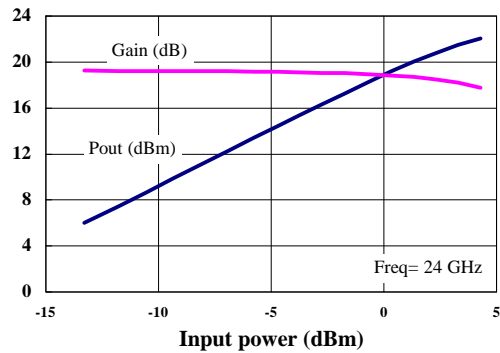
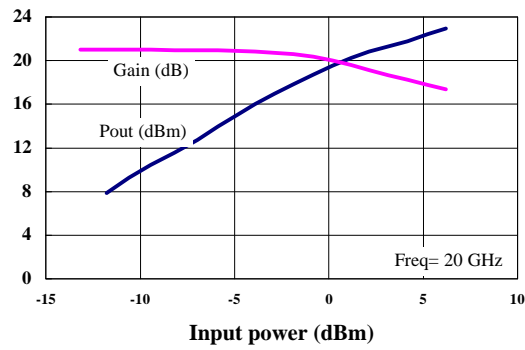
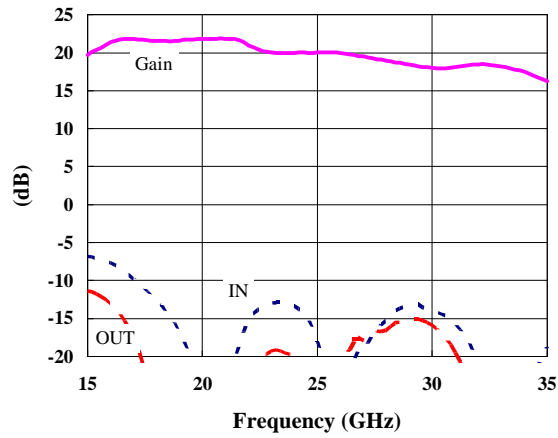

## Chip Assembly and Mechanical Data

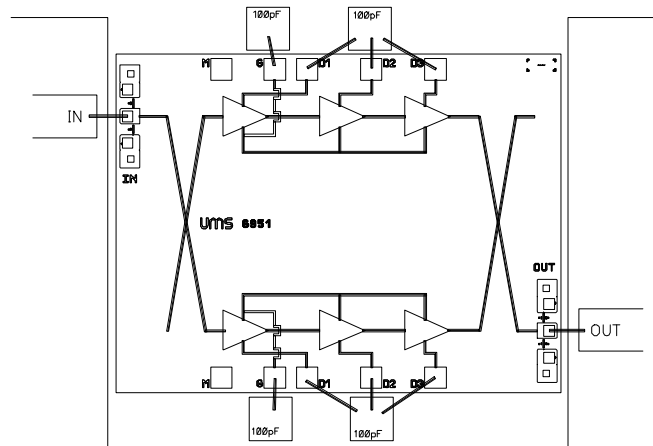

Note : Supply feed should be capacitively bypassed.

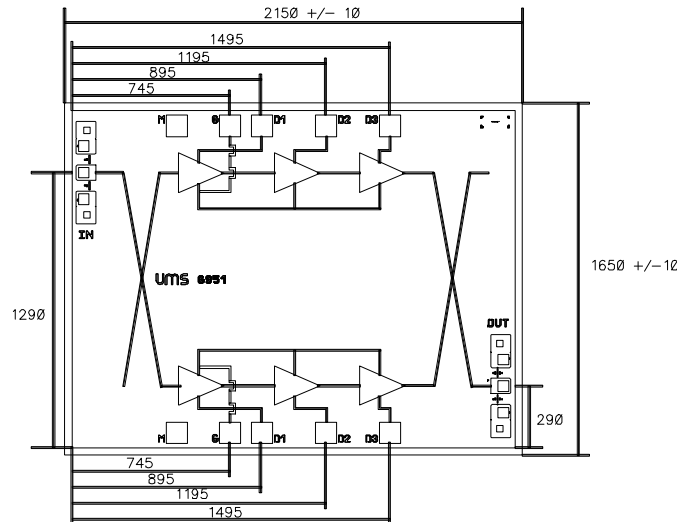

**Bonding pad positions.**

## Ordering Information

: CHA4092-99F/00

**united monolithic semiconductors**

**S.A.S.** assumes no responsibility for the consequences of use of such information nor for any infringement of patents or other rights of third parties which may result from its use. No license is granted by implication or otherwise under any patent or patent rights of **united monolithic semiconductors S.A.S.** Specifications mentioned in this publication are subject to change without notice. This publication supersedes and replaces all information previously supplied. **United monolithic semiconductors S.A.S.** products are not authorised for use as critical components in life support devices or systems without express written approval from **united monolithic semiconductors S.A.S.**