

Construction

- Dielectric: Polypropylene film
- Gas-impregnated / dry type
- Concentric winding
- Wave cut
- Extruded round aluminum can with stud
- Provided with ceramic discharge module
- Triple safety system

Features

- Three phase, delta connected
- Self-healing technology
- Naturally air cooled (or forced air cooling)
- Indoor mounting

Typical applications

- For Power Factor Correction

Terminals

- SIGUT terminals

Mounting parts

- Threaded stud at bottom of can
(max. torque = 10 Nm for M12)

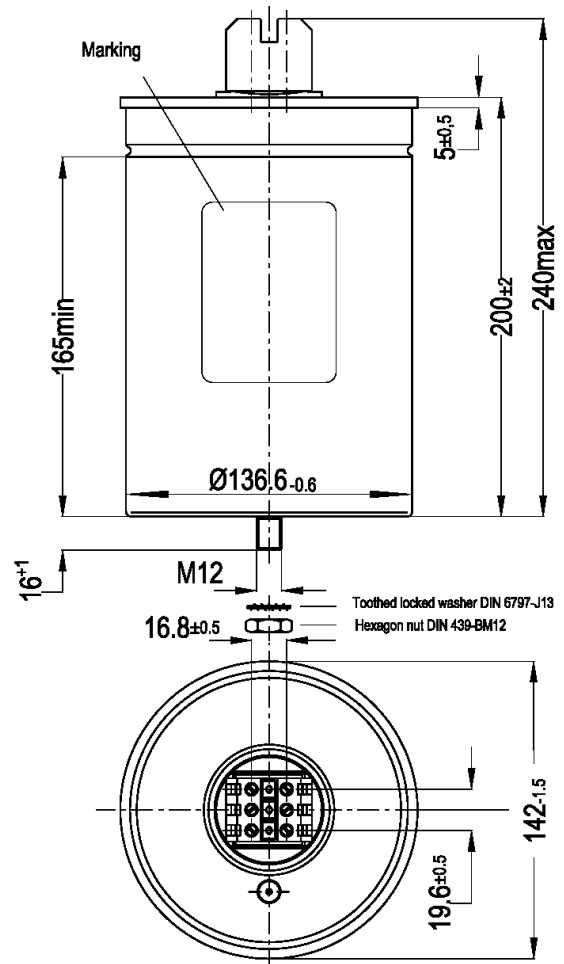
Dimensional drawing

All dimensions in mm

Technical data and specifications

Characteristics		
Rated capacitance C_R	3 x 115 μ F	
Tolerance	-5 / +10%	
Connection	D (Delta)	
Rated voltage V_R	480 VAC	
Rated frequency f_R	50 Hz	60 Hz
Output	25 kvar	30kvar*)
Rated current I_R	30 A	36A
tan δ (dielectric)	0.2 W / kvar	

*) valid for -40/B



Power Capacitors	B25667B4347A375
Power Factor Correction	MKK480-D-25-01

Maximum ratings	
U_{max} (up to 8 h daily)	530 VAC
U_{max} (up to 1 min)	620 VAC
I_{max}	$1.3 \times I_R$ (A)
I_S	$200 \times I_R$ (A)

Test data	
U_{TT}	1,050 VAC / 50 Hz during 10 s
U_{TC}	3,000 VAC / 50 Hz during 10 s
$\tan\delta$ (50 Hz)	≤ 0.6 W / kvar

Climatic category / -40/D	
T_{min} (-)	40 °C
T_{max} (+)	55 °C
Humidity	av. rel. < 95%
Maximum altitude	4,000 m

Mean life expectancy	
t_{LD}	Up to 115,000 hours
Max. 5000 switchings per year acc. to IEC 60831	

Design data	
Dimensions ($\varnothing \times l$)	142 x 200 mm
Weight approx	2.2 kg
Impregnation	Dry, inert gas
Fixing	Threaded bolt M12
Max. torque (Al can stud)	10 Nm
Mounting position	Any mounting position possible. See "Maintenance and Installation Manual" for further details.

Label design



C_N	$3 \times 115.2 \mu F +10/-5\%$	Δ	SH
U_N	$Q_N/50$ Hz	$Q_N/60$ Hz	
480 V	25,0 kvar	30,0 kvar	
465 V	23,5 kvar	28,2 kvar	
440 V	21,0 kvar	25,2 kvar	
$U_i = 3/-kV$	-40/D		
Overpressure disconnecter		Dry, Inert Gas	
IEC 60831(96)			
AFC 10 kA	-40...+55°C		
Internally protected			
CSA C22.2 No.190		E 12/06	
Made by EPCOS			



Power Capacitors

B25667B4347A375

Power Factor Correction

MKK480-D-25-01

Terminals

Degree of protection	Isolated terminals, IP20
Max. torque	1.2 Nm
Terminal cross section	16 mm ² (5 AWG)
Maximum terminal current	50 A
Creepage distance	12.7 mm
Clearance	9.6 mm

Safety

Mechanical safety	Overpressure disconnecter
Max. short circuit current	(AFC: 10 kA)
Discharge resistor time	≤ 1 min (75 V)

Reference Standards

IEC 60831-1/2, UL 810-5th edition

Certification: cUL file E238746

△ Please read information about PFC capacitors and cautions as well as installation and maintenance instructions (Power Factor Correction Product Profile, actual version, and Installation and Maintenance Instructions for PFC-capacitors, available in the Internet) to ensure optimum performance and prevent products from failing, and in worst case, bursting and fire.
Information given in the PFC-product profile and values given in the data sheet reflect typical specifications. You are kindly requested to approve our product specifications or request our approval for your specification before ordering.

© EPCOS AG 2005. All Rights reserved. Reproduction, publication and dissemination of this data sheet, enclosures hereto and the information contained therein without EPCOS' prior express consent is prohibited. The information contained in this data sheet describes the type of component and shall not be considered as guaranteed characteristics. Purchase orders are subject to the General Conditions for the Supply of Products and Services of the Electrical and Electronics Industry recommended by the ZVEI (German Electrical and Electronic Manufacturers' Association), unless otherwise agreed.