

A Discrete Approach to Battery Charging for Cellular Phones

Guy Moxey and Michael Speed

INTRODUCTION

All portable cordless appliances must receive power from an external source, whether it's a wall cube adapter, car charger, or docking station. This external source will then charge, in a predetermined fashion, the equipment's internal battery.

In the case of a portable phone, the power management system will incorporate charging control circuitry to regulate the voltage supplied to the battery from the external charger. External charging equipment—whether wall cubes or chargers that utilize car cigarette lighters—will supply a continuous but unregulated voltage to the phone, typically 4.2 V for a single Lithium-ion (Li+) cell. A typical charging design is explored in Appendix A.

Charge control for a Li+ cell is most commonly implemented by a discrete MOSFET in series with a Schottky diode, controlled via the onboard power management ASIC or system microprocessor. Integration of these two discrete power components into a single power package, such as the ChipFET™, reduces size and simplifies the assembly.

To this end, moving away from a separate Schottky diode and MOSFET to the single package integration of both devices, as in the Vishay Siliconix LITTLE FOOT Plus™, may have significant advantages. However, in an integrated package both components operate in a highly dissipative manner, making the choice of package a critical decision.

The LITTLE FOOT Plus Schottky diodes come in a variety of packages, with a range of $r_{DS(on)}$ values. Just as important to the performance of the charger as $r_{DS(on)}$ values are the thermal ratings of the packages. From the table below we can see the choices of R_{thJA} values available in today's industry-standard surface-mount packages.

TABLE 1. LITTLE FOOT Plus PACKAGE OPTIONS	
Device	R_{thJA} (°C/W) Typical
SO-8 — Si4833DY	90
TSSOP-8 — Si6923DQ	115
TSOP-6 — Si3853DV	130
1206-8 ChipFET — Si5853DC	90

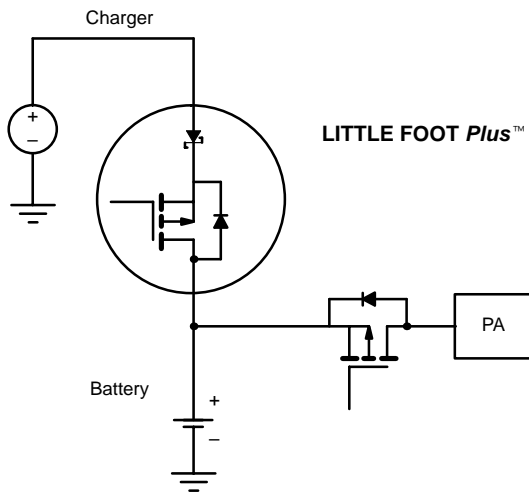

FIGURE 1. LITTLE FOOT Plus™ Schottky—The Integrated Solution of MOSFET and Schottky in One Power Package

Regardless of the charging device selected, the designer is still bound by space, cost, and efficiency considerations. There is therefore an obvious desire to increase levels of integration and reduce the component count and board size.

POWER DISSIPATION ISSUES

To select the correct part in the smallest package, the power dissipated by the two power devices must be examined. In the case of the charger switch, there are two modes of operation to consider.

In the first phase of charging, constant current is used and the MOSFET is operated in the linear mode. In this mode the device is effectively a variable resistor used to regulate the battery charging current.

Once the battery has charged to the predetermined 4.1-V level, the system voltage loop will begin to reduce the charging current in order to maintain the desired float voltage, hence the constant-voltage mode. For constant-voltage operation, the controller will terminate the MOSFET linear operation and revert to a pulse width modulation (PWM) mode. The MOSFET is driven as a fully-saturated (Ohmic) switch.

The Schottky diode is always required in series with the switch to prevent reverse current flow through the MOSFET's body drain diode when the external power source is unplugged or unpowered. Using separate MOSFETs and Schottkys rather than an integrated package consumes valuable board space.

CONSTANT-CURRENT MODE

As the MOSFET operates in the linear mode during constant-current charge control, the device losses can be simply calculated from Ohm's law:

$$P_{\text{LOSS}} = (V_{\text{BAT(max)}} - V_{\text{BAT(min)}}) \times I_{\text{OUT}}$$

As an effective linear regulator, the MOSFET functions in a high-dissipation mode. In addition, the series Schottky diode contributes to the overall power loss. Typical charging currents range from 400 mA to 700 mA, with the Li+ battery voltage varying from 4.1 V (fully charged) to 3.0 V (discharged). So at a 500-mA charging current, the charging system for a Li+ cell will have to dissipate:

$$P_{\text{LOSS MOSFET}} = (4.1 - 3.0) \times 0.5 = 0.55 \text{ W}$$

$$P_{\text{LOSS Schottky}} = V_F \times I_F = 0.48 \times 0.5 = 0.24 \text{ W}$$

In total, under constant current charging the total discrete power loss = 0.79 W

CONSTANT-VOLTAGE MODE

For the constant-voltage portion of the charge cycle, the MOSFET is fully saturated. Any consequent losses will be minimal and, assuming the worst-case scenario of T_J of 150°C and V_{GS} of 2.5 V, can be found from:

$$P_D \text{ Conduction} = (I_{\text{rms}})^2 \times r_{\text{DS(on)}} \text{ W}$$

$$= (0.5)^2 \times 0.232$$

$$= 0.058 \text{ W}$$

$$P_D \text{ Switching} = \frac{1}{2} V_L (t_r + t_f) \times F_S \text{ W}$$

Assuming switching of 100 Hz

t_r and a t_f value of 1 μs .

$$0.5 \times (4.1 \times 0.5) \times (1 \times 10^{-6} + 1 \times 10^{-6}) \times 100 = 2 \text{ mW}$$

Therefore, the losses generated from the MOSFET under constant-voltage operation are much less—approximately 7.6% —than the losses generated under constant-current operation.

SMD PACKAGE THERMAL PERFORMANCE—

Can we dissipate the heat with *LITTLE FOOT Plus*?

Ambient temperatures usually quoted for component calculation within a cell phone range between 50°C to 65°C,

with 60°C as the benchmark. Therefore, to optimize the power dissipation to the smallest MOSFET package the following thermal equation can be used:

$$P_D = (T_{J(\text{max})} - T_{\text{amb}}) / R_{\text{thJA}}$$

Where:

$$P_D = 0.79 \text{ W}, T_{J(\text{max})} = 150^\circ\text{C} \text{ and } T_{\text{amb}} = 60^\circ\text{C}$$

Hence re-arranging for $R_{\text{thJA}} = 114^\circ\text{C/W}$.

Good engineering practice allows a safety margin of 10% on the $T_{J(\text{max})}$ value, thus decreasing the allowable package R_{thJA} to approximately 104°C/W.

From both the above calculation and Table 1, we can deduce that the best-fit package for the MOSFET plus Schottky, while still providing suitable power dissipation, are the SO-8 package and the recently introduced ChipFET™ 1206 package.

However, moving upward in package footprint may not be an option when heavily restrained by the device size. Therefore the new ChipFET 1206 package offers a typical R_{thJA} of only 90°C/W, a footprint 40% smaller than a TSOP-6, and a thermal performance previously possible only with the SO-8 package.

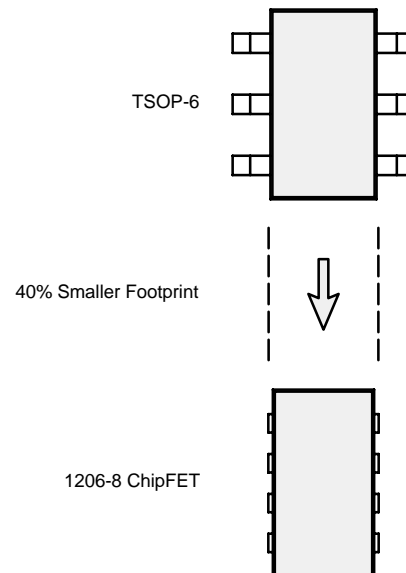
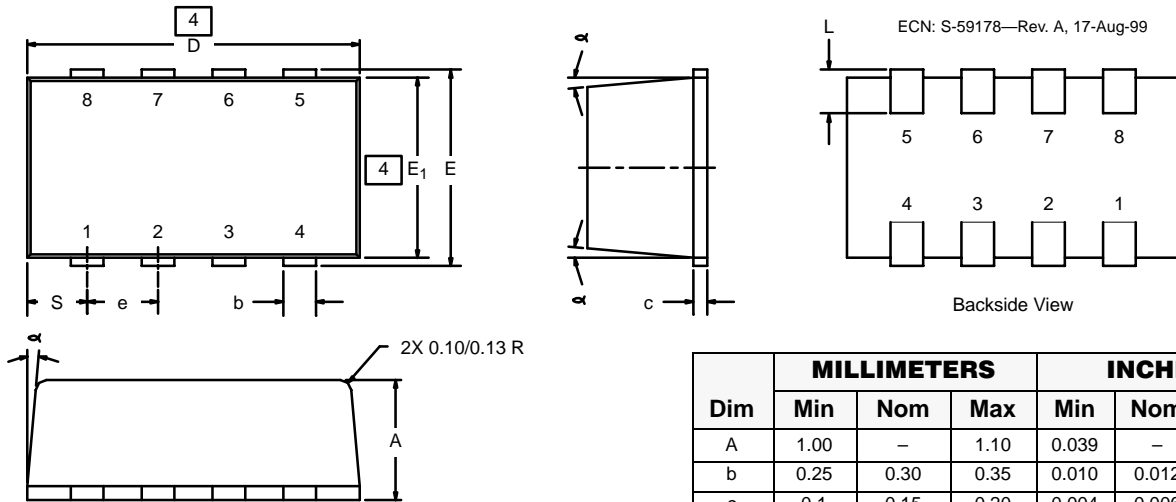

FIGURE 2.

PACKAGE DIMENSIONS—1206-8 ChipFET™



NOTES:

- 1 All dimensions are in millimeters
- 2 Mold gate burrs shall not exceed 0.13 mm per side.
- 3 Leadframe to molded body offset in horizontal and vertical shall not exceed 0.08 mm.
- 4 Dimensions exclusive of mold gate burrs.
- 5 No mold flash allowed on the top and bottom lead surface.

Dim	MILLIMETERS			INCHES		
	Min	Nom	Max	Min	Nom	Max
A	1.00	—	1.10	0.039	—	0.043
b	0.25	0.30	0.35	0.010	0.012	0.014
c	0.1	0.15	0.20	0.004	0.006	0.008
D	2.95	3.05	3.10	0.116	0.120	0.122
E	—	—	1.80	—	—	0.071
E ₁	1.55	1.65	1.70	0.061	0.065	0.067
e	0.65BSC			0.0256BSC		
L	0.30	—	0.45	0.012	—	0.018
S	0.55BSC			0.022BSC		
α	5°Nom			5°Nom		

Focusing on the Si5853DC, this device contains a 20-V p-channel MOSFET—with a 160-mΩ $r_{DS(on)}$ value at a 2.5-V gate drive—plus a 20-V, 1-A Schottky diode. From the previous calculations, it can be seen that the Si5853DC can be used as a constant-current/constant-voltage charging switch, thus eliminating the use of two separate devices and saving significant board space. From our working example, with a 500-mA charging current the die temperature is obtained from:

$$T_J = (T_{amb} \times P_D) + R_{thJA}$$

$$T_J = (60^\circ\text{C} \times 0.79) + 90^\circ\text{C/W}$$

$$T_J = 137.4^\circ\text{C}$$

This calculation proves that the Si5853DC is a satisfactory solution for a typical constant-current/constant-voltage charging strategy, and can effectively replace a separate series connected MOSFET and Schottky diode, as is commonly used within a cellular phone.

Thermal Resistance Corroboration Between a 1-in² PCB and a Cellular-Size PCA

The R_{thJA} value—90°C/W—that was used in the calculations was based on the value measured on a 1-in² PCB with 1-oz copper on both sides, as is typically used for the characterization of power MOSFET packages.

The subsequent characterization used a cellular-size PCA, so using a point from this curve to compare thermal resistance values—i.e., the 0.8-W point on the graph for 1206-8 ChipFET—then:

$$\Theta_{JA} = T_J - T_A/P_D$$

$$\Theta_{JA} = 98.5^\circ\text{C} - 25^\circ\text{C}/0.8$$

$$\Theta_{JA} = 92^\circ\text{C/W}$$

The resulting Θ_{JA} value is close to the 1-in² PCB value of 90°C/W, adding credence to the earlier calculations.

TEST RESULTS

The following graph displays the power dissipation performance of the TSOP-6 vs. the 1206-8 on a cellular-size PCA.

The TSOP-6 package has been used to compare performance due to its status as the preferred footprint for power MOSFETs in cellular designs.

Incremental steps of power were dissipated in each device and the corresponding junction temperature was measured. The 1206-8 ChipFET has superior P_D performance at all reference points, i.e., $T_J = 100^\circ\text{C}$ (T_A of 25°C is included in this value).

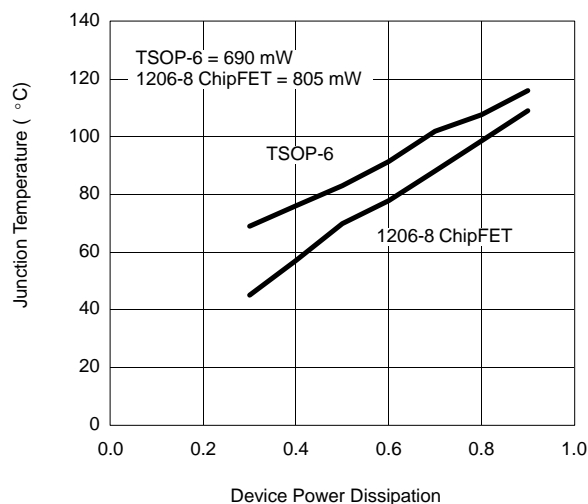

FIGURE 3. Comparison of TSOP-6 vs. ChipFET

Both examples (practical and theoretical) demonstrate the validity of using the LITTLE FOOT *Plus* MOSFET and Schottky integration power package.

The Si5853DC has been shown to be a viable application for the charger switch in single lithium-ion charging schemes.

ASSOCIATED MATERIAL

1. *Design Challenges for Battery Operated Power Management Systems*: Guy Moxey, Vishay Siliconix, PCIM2000 Europe.
2. *Leadless Power Packaging Signals a New Era for Surface Mount Semiconductor Switches*: Guy Moxey, Vishay Siliconix, *Electronic Engineering*, June 2000 Issue.
3. *Single-Channel 1206-8 ChipFET™ Power MOSFET Recommended Pad Pattern and Thermal Performance*: Michael Speed, Vishay Siliconix: TA811, www.vishay.com.

APPENDIX A

A Typical Charging Scheme

The world market for high-density rechargeable batteries as a whole is in a transition phase between market development and market maturation. The four most common chemistries used to power portable equipment are Nickel Cadmium (NiCd), Nickel Metal Hydride (NiMH), Lithium Ion (Li+) and Lithium Polymer (LiP). NiCd is currently in market retirement, NiMH is in full maturation, Li+ is in the market development stage and new alternatives like LiP are in market gestation. For today's cellular phone, a single-cell Li+ cell is often the battery of choice due to its small size and high energy density.

Li+ cells are generally suited to a constant-current/constant-voltage charging strategy and although relatively simple to implement, charging the cell actually requires precise control of the "float voltage" region in order to obtain the maximum capacity with long cell life. In summary, if the voltage is too low, the cell will not be fully charged; if the voltage is too high, the cycle life is significantly degraded. In addition, excessive over- or under-charge of a Li+ cell can result in catastrophic failure of the unit with possible explosion.

As stated, the charging of a single Li+ cell will follow a CC/CV strategy, as shown in the graph below. Region 1 is CC, region 2 is CV.

A fully discharged cell (typically 3 V) will initially be charged by a constant current, since the cell's voltage is well below the 4.1-V constant voltage limit. Once the cell's voltage rises to the float voltage of 4.1 V, the charging circuitry limits the further rise in terminal voltage and the charging current naturally begins to decline. Typically, manufacturers recommend that the charging sequence be terminated roughly one hour after the current has fallen to 10% of its peak value.

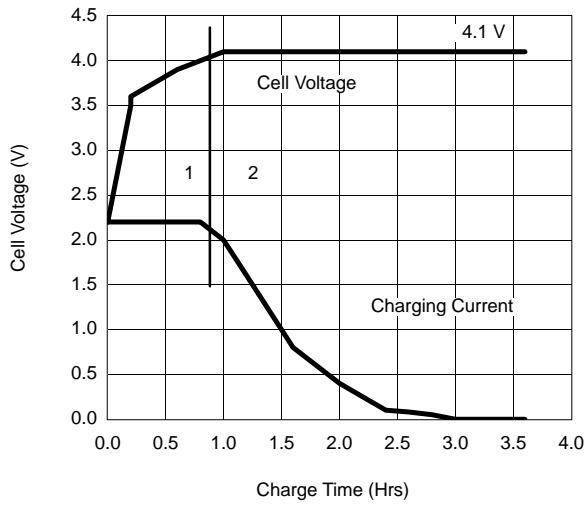

FIGURE 4.