

AZ DISPLAYS, INC.

1. MECHANICAL DATA

(1) Product No.	AGM2416A
(2) Module Size	74.6 (W)mm X 56.1 (H)mm X 5.5 (D)mm
(3) Dot Size	0.23 (W)mm X 0.23 (H)mm
(4) Dot Pitch	0.24 (W)mm X 0.24 (H)mm
(5) Number of Dots	240 (W) X 160 (H) Dots
(6) Duty	1/160
(7) LCD Display Mode	FSTN: Black and White(Normally White/Positive Image) Rear Polarizer: <input type="checkbox"/> Reflective <input type="checkbox"/> Transflective <input type="checkbox"/> Transmissive
(8) Viewing Direction	<input type="checkbox"/> 6 O'clock <input type="checkbox"/> 12 O'clock
(9) Backlight	<input type="checkbox"/> W/O <input type="checkbox"/> EL (White) <input type="checkbox"/> EL (Blue Green)
(10) Weight	W/O B/L : 26 g (Approx.) EL B/L : 28 g (Approx.)
(11) Controller	Excluded
(12) DC/DC Converter	Excluded

Revised: May 21, 2001

2. ABSOLUTE MAXIMUM RATINGS

(1) ELECTRICAL ABSOLUTE RATINGS

VSS=0 V Standard

ITEM	SYMBOL	MIN	MAX	UNIT	COMMENT
Power Supply for Logic	VDD-VSS	-0.3	6.5	V	
Input Voltage	VEE-VSS	0	27	V	
Static Electricity	-	-	-	-	Note 1

(2) ENVIRONMENTAL ABSOLUTE MAXIMUM RATINGS

ITEM	OPERATING		STORAGE	
	MIN.	MAX.	MIN.	MAX.
Ambient Temperature	0	50	-20	70
Humidity (Without Condensation)	Note 2,4		Note 3,4	
Vibration(Note 5)	-		49m/s ² (5G)	

Note 1 LCM should be grounded during handling.

Note 2 Ta ≤ 50°C : 85%RH max
 Ta > 50°C : Absolute humidity must be lower than the humidity of 85%RH at 50°C

Note 3 Ta at -20°C will be < 48 hrs, at 70°C will be < 120 hrs

Note 4 Background color will change slightly depending on ambient temperature.
 This phenomenon is reversible.

Note 5

Frequency (HZ)	10~55~10/1 min
Vibration Width	1.5 m/m
Vibration Direction	X/Y/Z
Vibration Time	15 min/cycle X 3 directions

3. ELECTRICAL CHARACTERISTICS

(VDD = 3.3V±10%)

ITEM		SYMBOL	CONDITION	MIN.	TYP.	MAX.	UNIT		
Supply voltage for logic		VDD-VSS	—	2.97	3.3	3.63	V		
Input Voltage		VIH	H level	0.8VDD	—	VDD	V		
		VIO	L level	0	—	0.2VDD	V		
Recommended LC Driving Voltage		VEE-VSS (Vop)	1/240 Duty 1/13 Bias	0°C	21.7	22.0	22.3	V	
				25°C	20.1	20.4	20.7		
				50°C	18.0	18.3	18.6		
Power Supply Current		IDD	VDD= 3.3 V VSS= 0V VEE-VSS= 20.4V FLM=70Hz PATTERN : □ ■ □ ■ □ ■ ■ □ ■ □ ■ □	—	0.55	—	mA		
		IEE		—	0.8	—			
EL Power Supply Current		I EL	65Vrms 250HZ	—	4.7	—	mA		
LCM	Surface Luminance	L	VDD= 3.3 V VSS= 0V VEE-VSS= 20.4V 65Vrms 250HZ	S227J	(Dots All On) ■ ■ ■ ■ ■ ■ PATTERN: (Dots All Off) □ □ □ □ □ □ □ □ □ □ □ □	—	0.4	—	cd/m ²
				H227K		—	0.9	—	
				H227KG		—	1.2	—	
				S227J		—	1.9	—	
				H227K		—	3.2	—	
				H227KG		—	4.2	—	

3.1 CHARACTERISTICS OF TOUCH SCREEN

ITEM	SYMBOL	CONDITION	MIN.	TYP.	MAX.	UNIT
Applied Rating Voltage	V _R	—	—	—	5.0	V
Applied Rating Current	I _R	At Contact Point of Top Layer with Bottom Layer	—	—	1.0	mA
Operating Temperature	T _{OPR}	20%~85% R.H. Max. Avoid Dew Condensation at Any Time	-10	—	60	°C
Storage Temperature	T _{STO}		-20	—	70	
Resistance of Terminal Electrodes	R _{ETD}	X Electrode	200	320	650	Ω
		Y Electrode	350	500	950	
Linearity	L	—	—	—	1.5	%
Insulation Resistance	R _{OFF}	V _{DC} =25V	20	—	—	MΩ
Activation Force	F _{ON}	NOTE 1	10	—	80	g
Transparency	T	According to JIS-K7015	—	83	—	%
Surface Hardness	S _H	According to JIS-K5400	3	—	—	H

NOTE 1 : force is given with R0.8 Polyacetal pen

4. OPTICAL CHARACTERISTICS

AT V_{OP}

ITEM MODE		Cr(Contrast Ratio)						θ(Viewing Angle)		φ(Viewing Angle)	
		0°C		25°C		50°C		25°C		25°C	
		MIN.	TYP.	MIN.	TYP.	MIN.	TYP.	MIN.	TYP.	MIN.	TYP.
G	L	—	5.5	—	5.0	—	4.0	—	74	—	±37
S	J	—	8.0	—	7.5	—	6.0	—	70	—	±35
H	K	—	8.0	—	6.5	—	5.0	—	68	—	±33
Z	L	—	9.0	—	8.5	—	6.5	—	68	—	±38
M	L	—	8.5	—	7.0	—	5.5	—	66	—	±33
NOTE		NOTE 6						NOTE 5			

NOTE :

G : REFLECTIVE

S : TRANSFLECTIVE(normal)

H : TRANSFLECTIVE
(high transparency)

M : 3M POLARIZER

Z : OTHER

L : NORMALLY WHITE 6 O'CLOCK

J : NORMALLY WHITE 6 O'CLOCK
(special lighter background color)

K : NORMALLY WHITE 6 O'CLOCK

AT φ=0° θ=0°

ITEM	SYMBOL	CONDITION	MIN.	TYP.	MAX.	UNIT	NOTE
Response Time (rise)	Tr	0°C	—	800	—	ms	NOTE 2
		25°C	—	230	—		
		50°C	—	100	—		
Response Time (fall)	Tf	0°C	—	300	—	ms	NOTE 2
		25°C	—	115	—		
		50°C	—	65	—		

(NOTE 1)

Definition of Operation Voltage(V_{op})

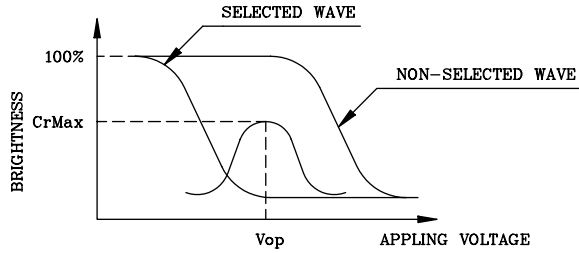

(positive type)

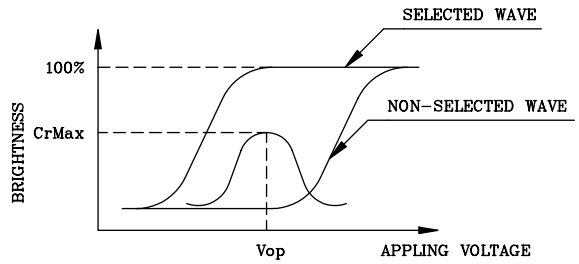

(negative type)

*Conditions

Viewing Angle : 0
 Frame Frequency : 70Hz
 Applying Waveform : I/N duty 1/a bias

(NOTE 2)

Definition of Response Time(T_r, T_f)

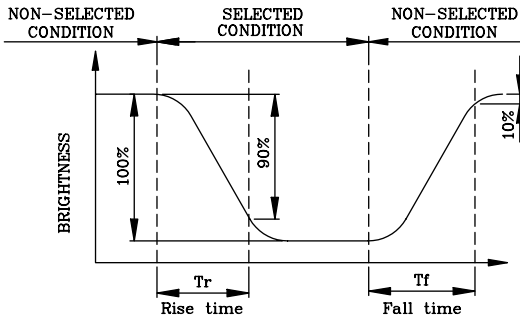

(positive type)

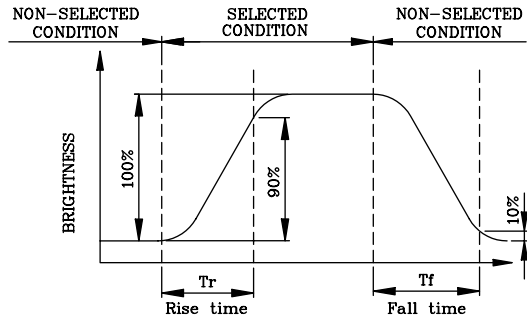

(negative type)

*Conditions

Operating Voltage : V_{op}
 Viewing Angle (θ, θ) : (0,0)
 Frame Frequency : 70Hz
 Applying Waveform : I/N duty 1/a bias

(NOTE 3)

Description of Measuring Equipment and Driving Waveforms

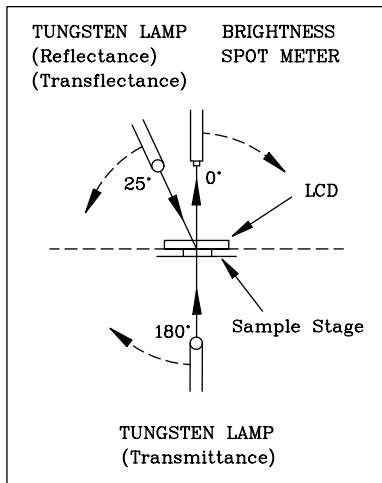

CONST.
TEMP.
CHAMBER

Multiplex Driving (I/N duty 1/a bias)

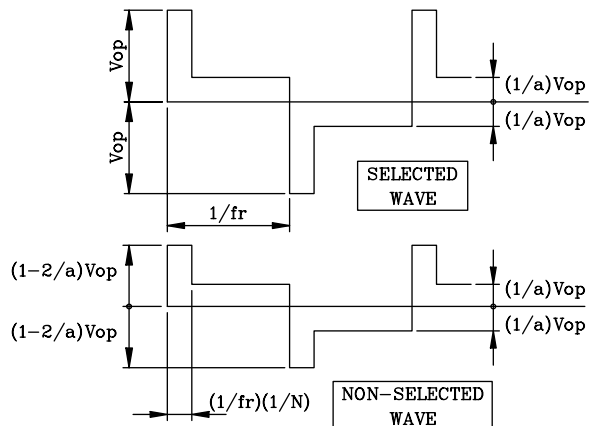

(NOTE 4)

Definition of Viewing Direction

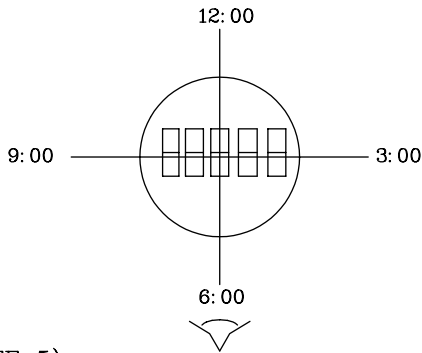

(NOTE 5)

Definition of Viewing Angle

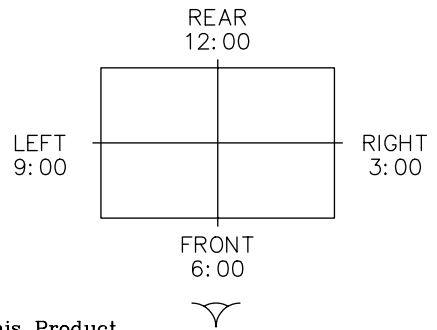
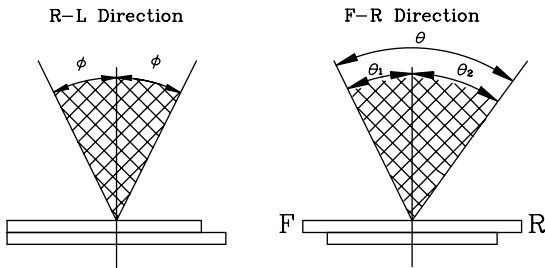

*For This Product
The Viewing Direction Is 6 O'clock
So $\theta_1 > \theta_2$

$$\theta = \theta_1 + \theta_2$$

*Conditions

- Operating Voltage : V_{op}
- Frame Frequency : 70Hz
- Applying Waveform : 1/N duty 1/a bias
- Contrast Ratio : larger than 2

(NOTE 6)

Definition of Contrast Ratio (Cr)

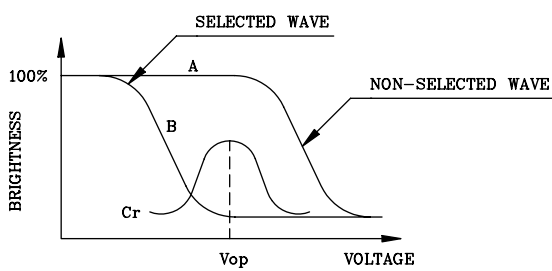

(positive type)

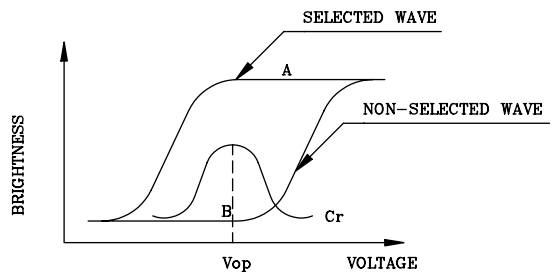

(negative type)

$$\text{Contrast Ratio : } Cr = A/B$$

*Conditions

- Viewing Angle : 0
- Frame Frequency : 70Hz
- Applying Waveform : 1/N duty 1/a bias

5. BLOCK DIAGRAM

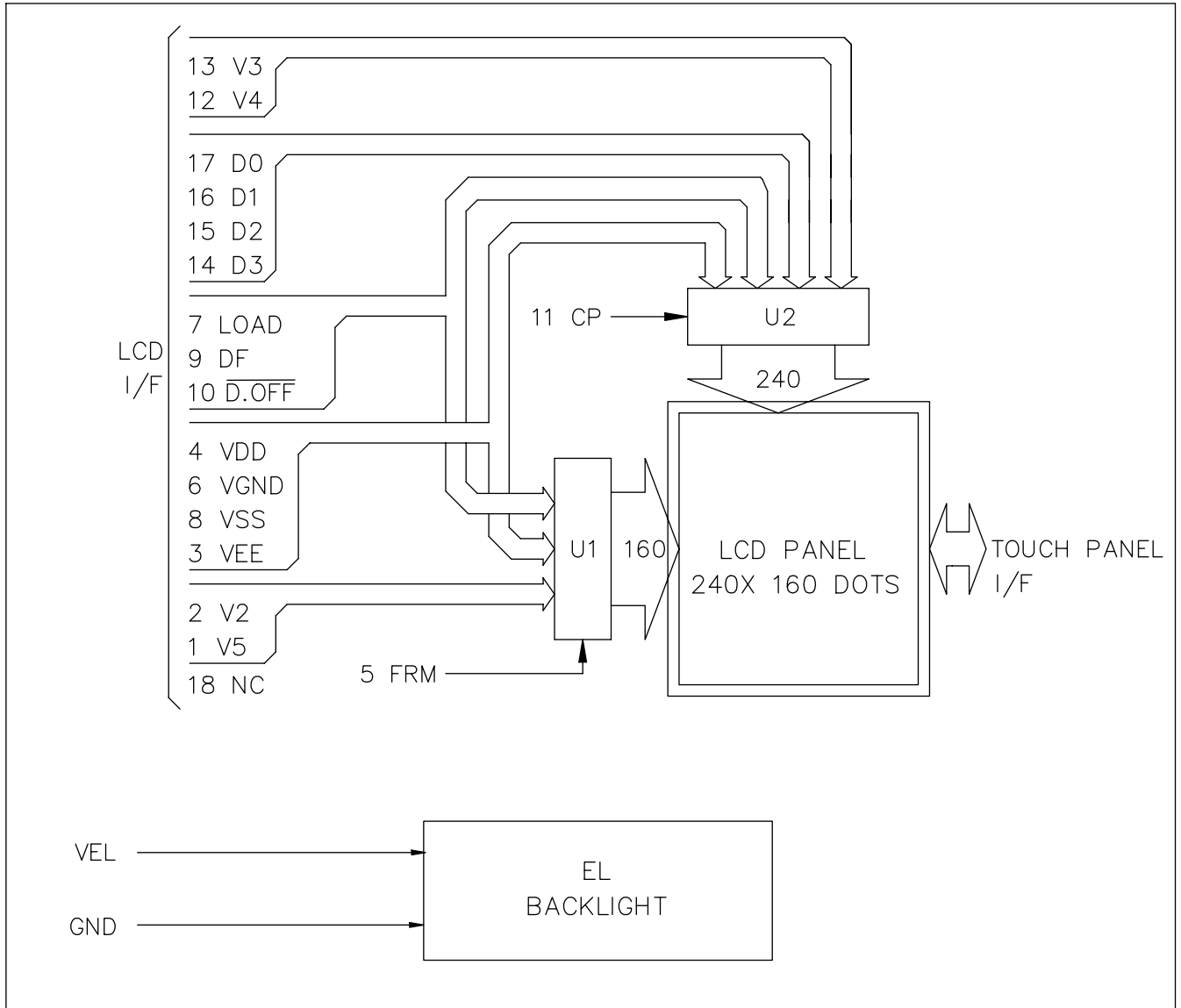

Note1 :

- 1) Controller and bias voltage supply circuit are not included.
- 2) VEE, VGND, V2, V3, V4 and V5 are power supply voltage for LCD.
($VEE > V2 > V3 > V4 > V5 > VGND$)
- 3) The bias is $1/13$, $VOP = VEE - VSS = 20.4 \text{ V}$.

6. INTERNAL PIN CONNECTION

LCD

Pin No.	Symbol	Function
1	V5	Bias voltage for non-select (Common driver)
2	V2	Bias voltage for non-select (Common driver)
3	VEE	Power supply for LCD (+V)
4	VDD	Power supply for logic (+3.3V)
5	FRM	Frame start signal (Data signal of the shift register of the common driver)
6	VGND	GND, Power supply for LCD
7	LOAD	1) Latch pulse of display data 2) Shift clock for common driver
8	VSS	GND
9	DF	Switch signal to convert LCD drive waveform into AC
10	$\overline{D.OFF}$	H : Display ON, L : Display OFF
11	CP	Clock pulse for segment shift register
12	V4	Bias voltage for non-select (Segment driver)
13	V3	Bias voltage for non-select (Segment driver)
14	D3	Input data signal
15	D2	Input data signal
16	D1	Input data signal
17	D0	Input data signal
18	N.C.	No connectoin

TOUCH PANEL

Pin No.	Symbol
1	Y2
2	X1
3	Y1
4	X2

7. POWER SUPPLY

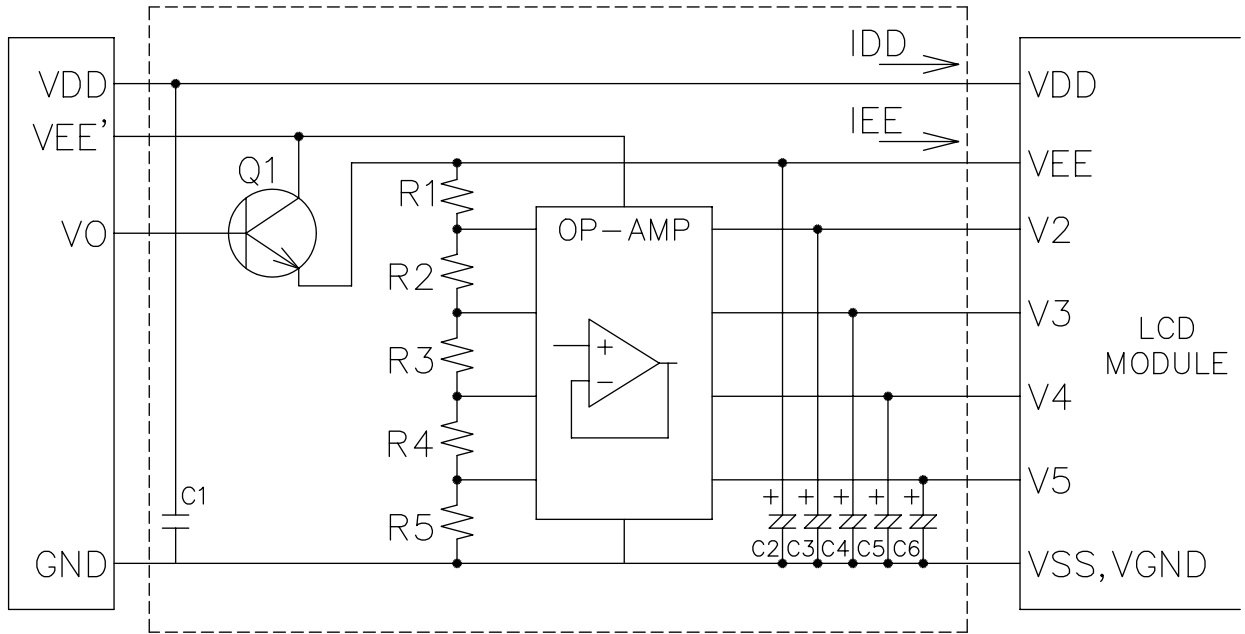

Q1 : 2SC1815

OP-AMP : LP324

$R1=R2=R4=R5=10K\Omega, R3=9R1=91K\Omega(1/13 \text{ Bias})$

$C1=0.1\mu F, C2\sim C6=3.3\mu F$

Note : EL Driving Method

- Constant Voltage Source Driving : AC 100 Vrms 400 Hz
- Inverter IC Driving : HV823 (Supertex) or SP4428CN(Sipex)

8. TIMING CHARACTERISTICS

8-1 INTERFACE TIMING

@ VDD=3.3V±10%, Ta= 0~50 °C

Item	Symbol	Test condition	Min.	Typ.	Max.	Unit
CP Cycle Time	tC	Fig. a	82	-	-	ns
CP Pulse Width	tSWH,tSWL	Fig. a	28	-	-	ns
CP Rise/Fall Time	tCR,tCF	Fig. a	-	-	50	ns
Data Set Up Time	tDSU	Fig. a , Fig. b	20	-	-	ns
Data Hold Time	tDHD	Fig. a , Fig. b	23	-	-	ns
LOAD Cycle Time	tL	Fig. b	250	-	-	ns
LOAD "H" Pulse Width	tLWH	Fig. a , Fig. b	30	-	-	ns
LOAD Rise/Fall Time	tLR,tLF	Fig. b	-	-	50	ns
CP To LOAD Delay Time	tCL	Fig. a	30	-	-	ns
LOAD To CP Delay Time	tLC	Fig. a	65	-	-	ns
FRM TO LOAD SETUP TIME	tFLS	Fig. b	30	-	-	ns
FRM TO LOAD HOLD TIME	tFLH	Fig. b	50	-	-	ns

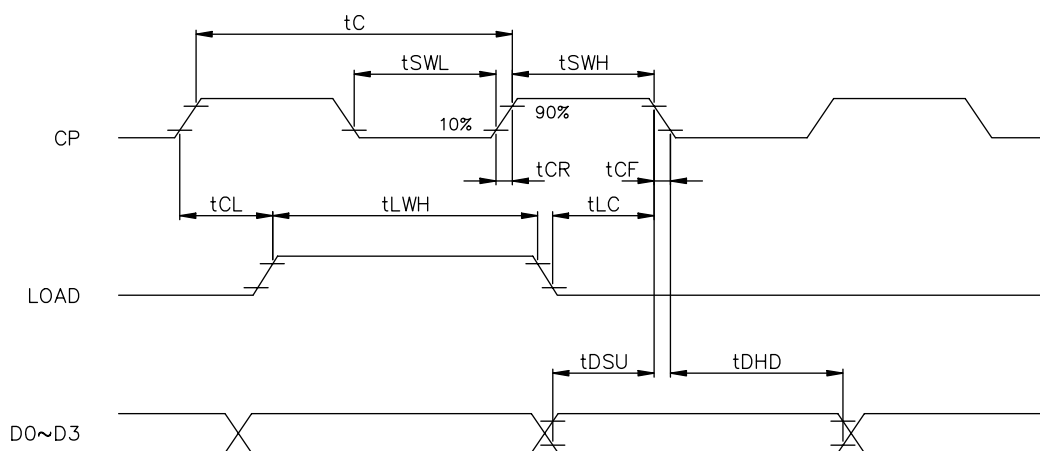

Fig . a Interface timing (SEGMENT)

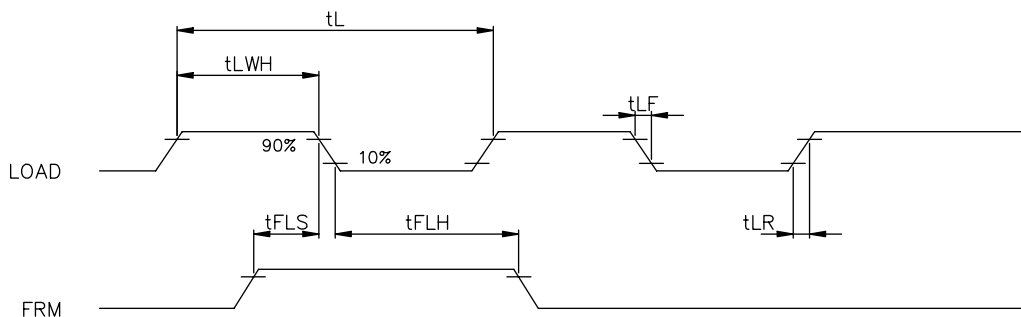
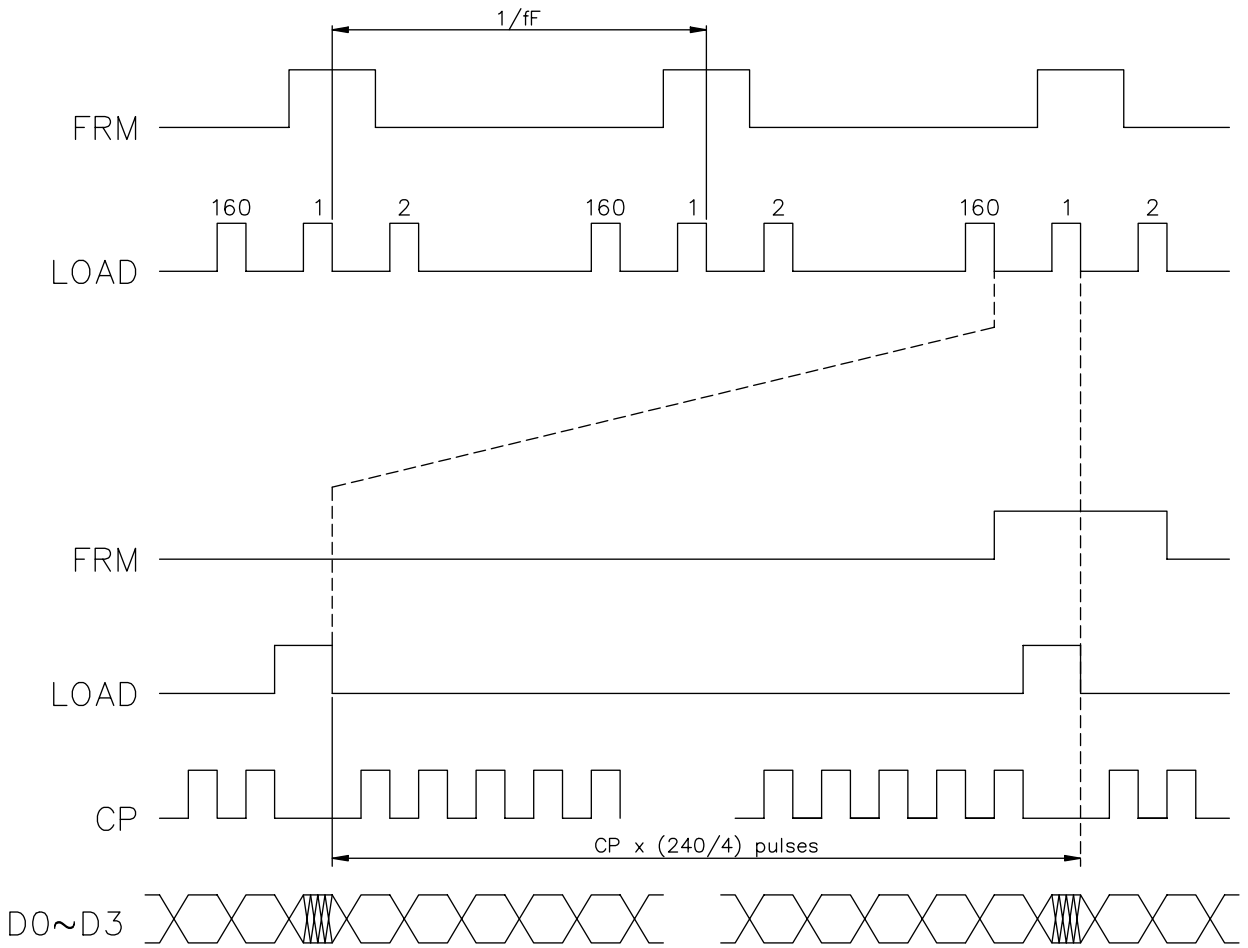
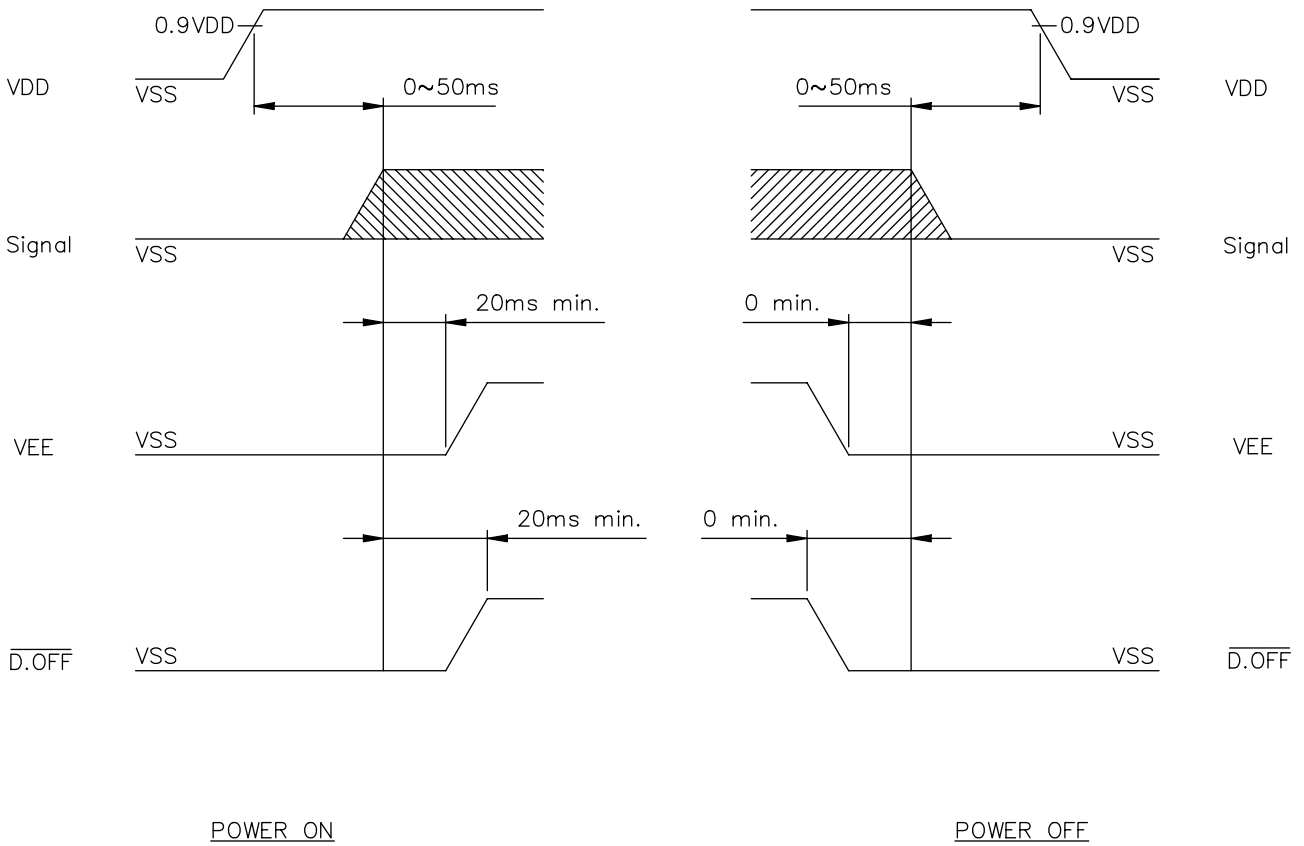

Fig . b Interface timing (COMMON)

8-2 TIMING CHART OF INPUT SIGNAL



8-3 POWER ON/OFF TIMING



Missing pixels may occur when the LCM is driven beyond the above power interface timing sequence.

8-4 DISPLAY PATTERN

	Column1	Column2	Column3	Column4	Column240
Row 1	1 • 1	1 • 2	1 • 3	1 • 4	1 • 240
Row 2	2 • 1	2 • 2	2 • 3		
Row 3	3 • 1	3 • 3			
	D0: (1 • 4) ↘ (1 • 8) • • • • (160 • 240) D1: (1 • 3) ↘ (1 • 7) • • • • (160 • 239) D2: (1 • 2) ↘ (1 • 6) • • • • (160 • 238) D3: (1 • 1) ↘ (1 • 5) • • • • (160 • 237)				
Row 160	160 • 1				160 • 240

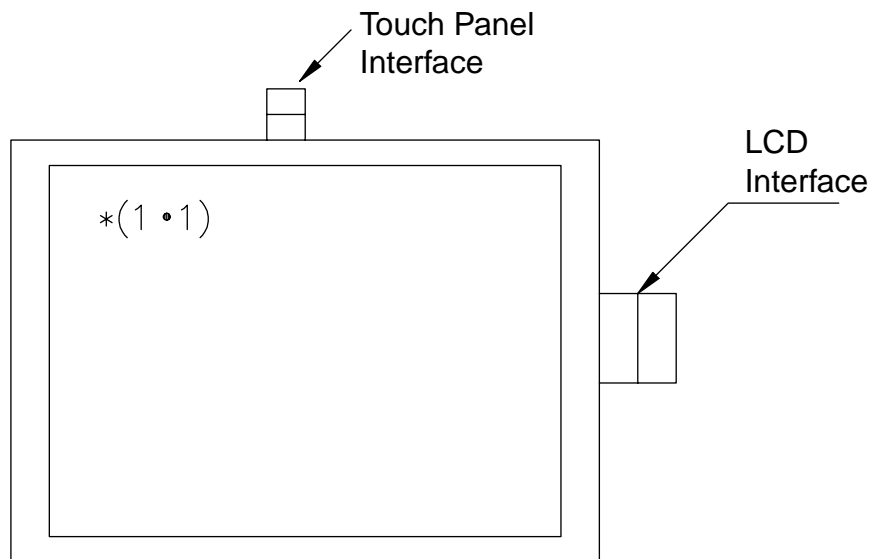

Reflective Version

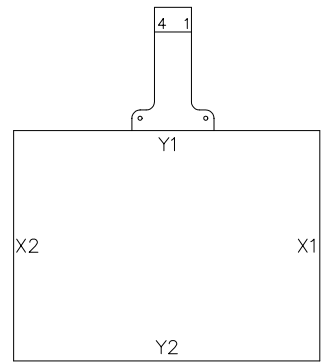
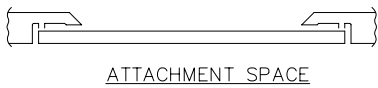
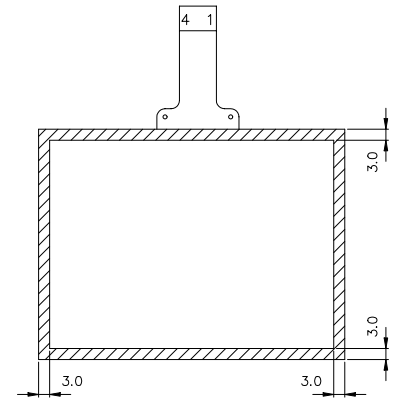

② Touch Panel CONNECTION

No.	Symbol
1	Y2
2	X1
3	Y1
4	X2

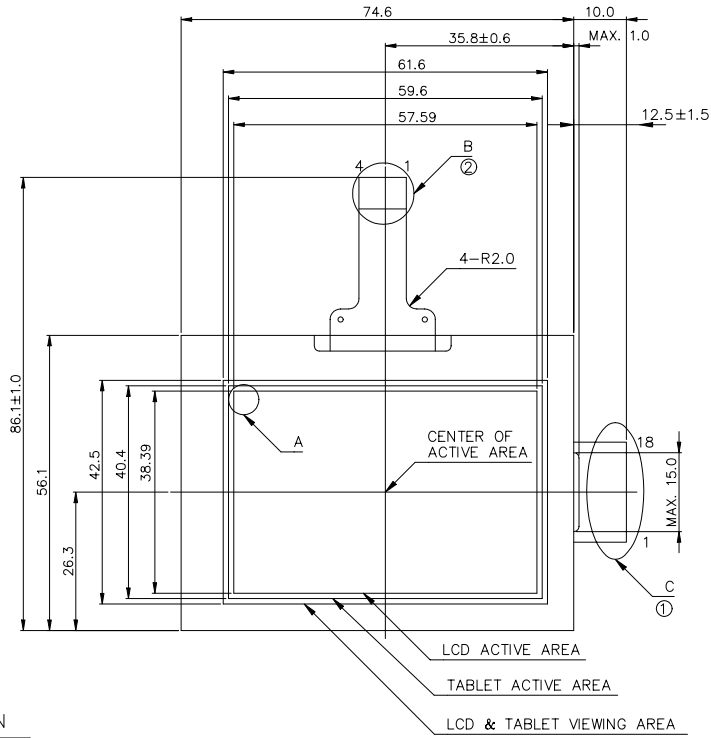

VIEWING DIRECTION

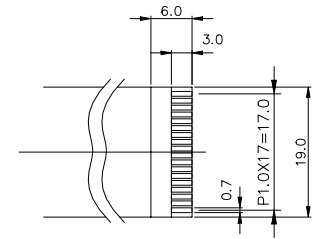
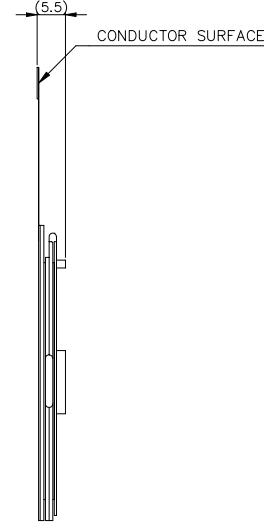

C DETAIL (透視面)
SCALE=1/1

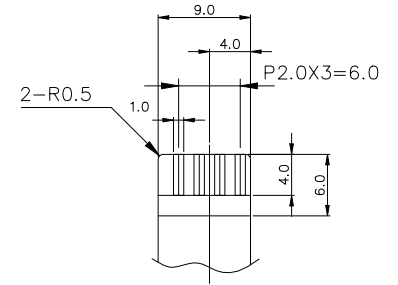

B DETAIL (透視面)
SCALE=1.5/1

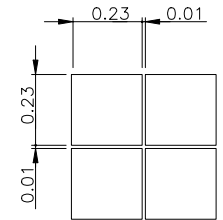

A DETAIL

① LCD CONNECTION

Pin No.	Symbol	Pin No.	Symbol
1	V5	10	D.OFF
2	V2	11	CP
3	VEE	12	V4
4	VDD	13	V3
5	FRM	14	D3
6	VGND	15	D2
7	LOAD	16	D1
8	VSS	17	D0
9	DF	18	NC

TOLERANCE LIST(S)

DIMENSION	TOLERANCE
$L \leq 6$	± 0.25 (mm)
$6 < L \leq 18$	± 0.3 (mm)
$18 < L \leq 50$	± 0.4 (mm)
$50 < L \leq 125$	± 0.5 (mm)
$125 < L$	± 0.6 (mm)

NOTE :

1.RESOLUTION : 240X160 DOTS

REV. NO.	DESCRIPTION	DATE	DESIGN	CHECK	APPROVE
	Modified new form	90.03.07	J.Y.Lin		

AZ DISPLAYS, INC.

AGM2416A

	NAME	DATE	THIRD ANGLE P.
APPROVE	Tony Chou	88.4.3	
CHECK	Louis Lee	88.4.3	
DESIGN	J.Y.CHEN	88.4.3	
DRAWN	MAY PING	88.4.3	

DWG. NO.	SCALE	UNIT
T A x 2 2 7 x x	1/1	mm

