

# AZ Displays, Inc.

## 1. MECHANICAL DATA

(1) Product No.	<b>AGM1212D</b>
(2) Module Size	92.0 (W)mm x 106.0 (H)mm x MAX 12.0 (D)mm (W/O , EL B.L.) 92.0 (W)mm x 106.0 (H)mm x MAX 14.5 (D)mm (LED B.L.)
(3) Dot Size	0.50 (W)mm x 0.50 (H)mm
(4) Dot Pitch	0.55 (W)mm x 0.55 (H)mm
(5) Number of Dots	128 (W) x 128 (H)Dots
(6) Duty	1/128
(7) LCD Display Mode	STN: <input type="checkbox"/> Gray <input type="checkbox"/> Yellow <input type="checkbox"/> Blue FSTN: <input type="checkbox"/> Black and White(Normal White/Positive Image) <input type="checkbox"/> Black and White(Normal Black/Negative Image) Rear Polarizer: <input type="checkbox"/> Reflective <input type="checkbox"/> Transflective <input type="checkbox"/> Transmissive
(8) Viewing Direction	<input type="checkbox"/> 6 O'clock <input type="checkbox"/> 12 O'clock <input type="checkbox"/> ___O'clock
(9) LCD Controller	BUILT-IN T6963C (TOSHIBA)
(10) Backlight	<input type="checkbox"/> W/O <input type="checkbox"/> EL <input type="checkbox"/> LED
(11) Weight	W/O B/L : 90.4g EL B/L : 96.5g LED B/L : 120.5g

# AZ Displays, Inc.

## 2. ABSOLUTE MAXIMUM RATINGS

### (1) ELECTRICAL ABSOLUTE RATINGS

GND=0V Standard

ITEM	SYMBOL	MIN	MAX	UNIT	COMMENT
Power Supply for Logic	VDD-GND	0	7.0	V	
Input Voltage	VI	GND	VDD	V	
Static Electricity	-	-	-	-	Note 1

Note 1 LCM should be grounded during handling

### (2) ENVIRONMENTAL ABSOLUTE MAXIMUM RATINGS

ITEM	NORMAL TEMP.				WIDE TEMP.			
	OPERATING		STORAGE		OPERATING		STORAGE	
	MIN.	MAX.	MIN.	MAX.	MIN.	MAX.	MIN.	MAX.
Ambient Temperature	0	50	-20	70	-20	70	-30	80
Humidity (Without Condensation)	Note 1,3		Note 2,3		Note 3,4		Note 3,5	

Note 1  $T_a \leq 50^\circ\text{C}$  : 85%RH max

$T_a > 50^\circ\text{C}$  : Absolute humidity must be lower

than the humidity of 85%RH at  $50^\circ\text{C}$

Note 2  $T_a$  at  $-20^\circ\text{C}$  will be  $< 48\text{hrs}$ , at  $70^\circ\text{C}$  will be  $< 120\text{hrs}$

Note 3 Background color changes slightly depending on ambient temperature.  
This phenomenon is reversible.

Note 4  $T_a \leq 70^\circ\text{C}$  : 75%RH max

$T_a > 70^\circ\text{C}$  : Absolute humidity must be lower

than the humidity of 75%RH at  $70^\circ\text{C}$

Note 5  $T_a$  at  $-30^\circ\text{C}$  will be  $< 48\text{hrs}$ , at  $80^\circ\text{C}$  will be  $< 120\text{hrs}$

# AZ Displays, Inc.

## 3. ELECTRICAL CHARACTERISTICS

( VDD=5V ± 10% )

ITEM	SYMBOL	CONDITION		MIN.	TYP.	MAX.	UNIT
Logic Circuit Power Supply	VDD-GND	-		4.75	5.0	5.25	V
Input Voltage	V <sub>IH</sub>	H level		0.8VDD	-	VDD	V
	V <sub>IL</sub>	L level		GND	-	0.2VDD	V
Recommended LCD Driving Voltage (NORMAL TEMP. LCM)	VDD-V <sub>0</sub> (V <sub>op</sub> )	1/12 Bias	0°C	18.4	19.4	-	V
			25°C	17.2	18.2	19.2	V
			50°C	15.4	16.7	-	V
Recommended LCD Driving Voltage (WIDE TEMP. LCM)	VDD-V <sub>0</sub> (V <sub>op</sub> )	1/12 Bias	-20°C	-	17.2	-	V
			0°C	-	16.1	16.2	V
			25°C	-	16.0	16.2	V
			50°C	15.6	15.7	-	V
			70°C	-	-	-	V
Supply Current (LCD)	I <sub>DD</sub>	VDD = 5.0V V <sub>0</sub> = -13.2V		17	21	29	mA
	I <sub>0</sub>			1.5	2.0	3.0	
LED POWER SUPPLY	I <sub>LED</sub>	V <sub>BL</sub> =5V R <sub>BL</sub> =5Ω		97	101	110	mA
EL POWER SUPPLY	I <sub>EL</sub>	V <sub>BL</sub> =110Vac 400Hz R <sub>BL</sub> =0Ω		-	-	10	mA

# AZ Displays, Inc.

## 4. OPTICAL CHARACTERISTICS

(FOR NORMAL TEMPERATURE MODE LCM)

AT  $V_{OP}$

ITEM MODE		Cr(Contrast Ratio)		$\theta$ (Viewing Angle)		$\phi$ (Viewing Angle)	
		25℃		25℃		25℃	
		MIN.	TYP.	MIN.	TYP.	MIN.	TYP.
R	A	—	—	—	—	—	—
	C	3.5	7	40	60	20	28
	J	4	8	35	60	20	35
S	A	—	—	—	—	—	—
	C	3	6	35	50	20	25
	J	—	—	—	—	—	—
note		NOTE6		NOTE5			

AT  $\phi=0^\circ$   $\theta=0^\circ$

ITEM	SYMBOL	CONDITION	MIN.	TYP.	MAX.	UNIT	NOTE
Response Time (rise)	Tr	0℃	—	270	540	ms	NOTE 2
		25℃	—	140	280		
		50℃	—	50	120		
Response Time (fall)	Tf	0℃	—	760	1500	ms	NOTE 2
		25℃	—	210	420		
		50℃	—	120	240		

note:

- S: TRANSFLECTIVE
- T: TRANSMISSIVE
- A: GRAY
- C: YELLOW
- E: BLUE
- G: NORMALLY BLACK
- J: NORMALLY WHITE

# AZ Displays, Inc.

## 4-1.OPTICAL CHARACTERISTICS

(FOR WIDE TEMPERATURE MODE LCM)

AT V<sub>OP</sub>

ITEM MODE		Cr(Contrast Ratio)		$\theta$ (Viewing Angle)		$\phi$ (Viewing Angle)	
		25℃		25℃		25℃	
		MIN.	TYP.	MIN.	TYP.	MIN.	TYP.
R	A	—	3.8	—	—	—	—
	C	—	4.1	—	—	—	—
	J	—	6.5	—	26	—	33
S	A	—	4.0	—	46	—	25
	C						
	J						
T	A	—	2.5	—	—	—	—
note		NOTE6		NOTE5			

AT  $\phi=0^\circ$   $\theta=0^\circ$

ITEM	SYMBOL	CONDITION	MIN.	TYP.	MAX.	UNIT	NOTE
Response Time (rise)	Tr	-20℃	—	—	—	ms	NOTE 2
		0℃	—	350	520		
		25℃	—	120	180		
		50℃	—	70	105		
		70℃	—	55	80		
Response Time (fall)	Tf	-20℃	—	—	—	ms	NOTE 2
		0℃	—	640	900		
		25℃	—	200	300		
		50℃	—	80	120		
		70℃	—	35	50		

note:

S: TRANSFLECTIVE  
T: TRANSMISSIVE  
A: GRAY  
C: YELLOW

E: BLUE  
G: NORMALLY BLACK  
J: NORMALLY WHITE

# AZ Displays, Inc.

## 5. BLOCK DIAGRAM

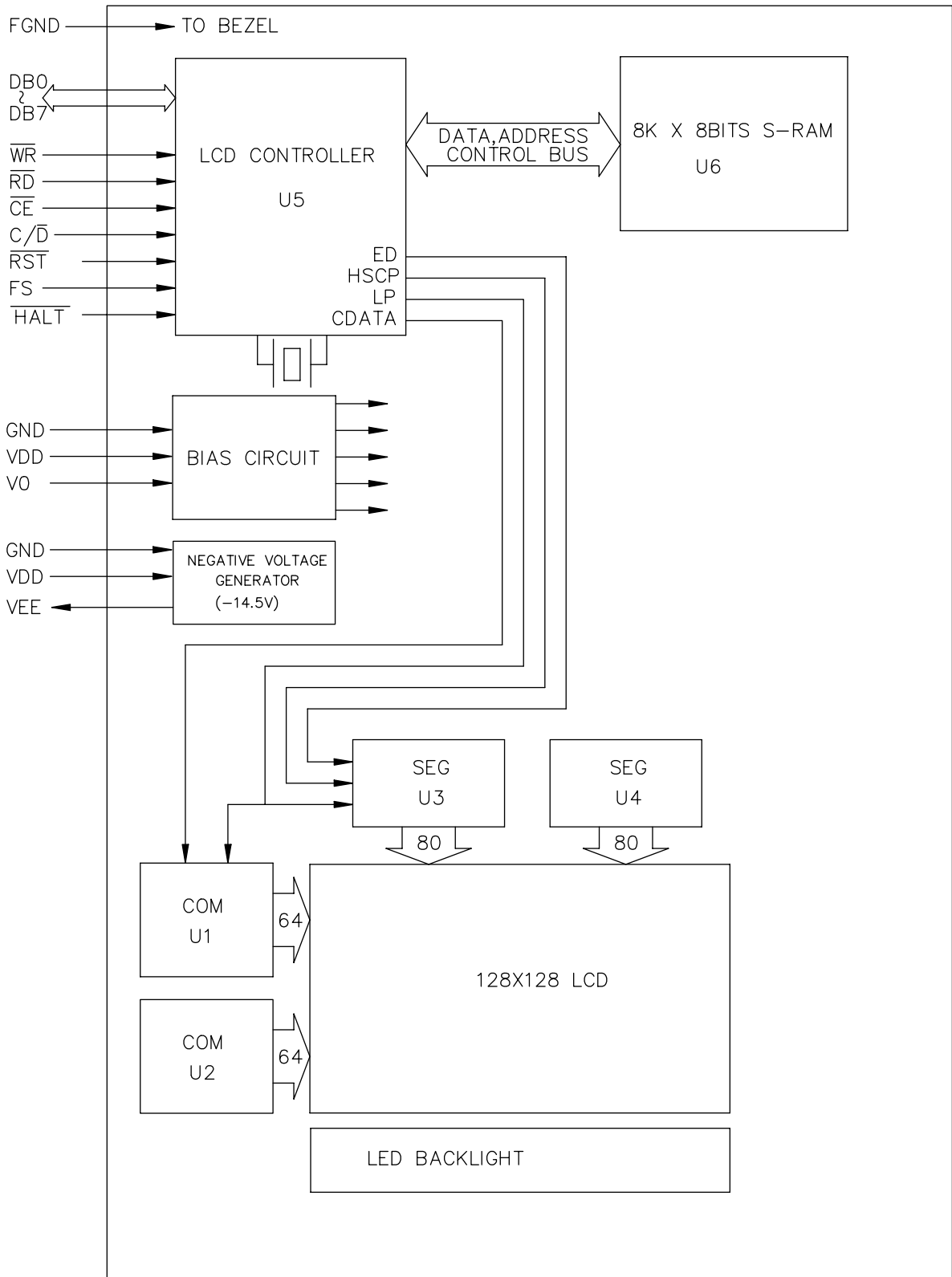

# AZ Displays, Inc.

## 6. INTERNAL PIN CONNECTION

PIN NO.	SYMBOL	FUNCTION
1	FGND	FRAME GROUND (0V)
2	V <sub>SS</sub>	GROUND
3	VDD	POWER SUPPLY FOR LOGIC (+5V)
4	V <sub>O</sub>	POWER SUPPLY FOR LC DRIVING
5	$\overline{WR}$	DATA WRITE
6	$\overline{RD}$	DATA READ
7	$\overline{CE}$	$\overline{CE}$ ="L", CHIP ENABLE
8	C/ $\overline{D}$	$\overline{WR}$ ="L",C/ $\overline{D}$ ="H" :COMMAND WRITE $\overline{WR}$ ="L",C/ $\overline{D}$ ="L" :DATA WRITE $\overline{RD}$ ="L",C/ $\overline{D}$ ="H" :STATUS READ $\overline{RD}$ ="L".C/ $\overline{D}$ ="L" :DATA READ
9	$\overline{RST}$	CONTROLLER RESET
10	D0	DATA INPUT/OUTPUT
11	D1	DATA INPUT/OUTPUT
12	D2	DATA INPUT/OUTPUT
13	D3	DATA INPUT/OUTPUT
14	D4	DATA INPUT/OUTPUT
15	D5	DATA INPUT/OUTPUT
16	D6	DATA INPUT/OUTPUT
17	D7	DATA INPUT/OUTPUT
18	FS	FONT SELECT    CONNECT TO VDD : 6X8 PIXELS/CHARACTER CONNECT TO GND : 8X8 PIXELS/CHARACTER
19	VEE	-14.5 V NEGATIVE VOLTAGE GENERATOR
20	$\overline{HALT}$	$\overline{HALT}$ ="L", CONTROLLER HALT

# AZ Displays, Inc.

## 7. POWER SUPPLY

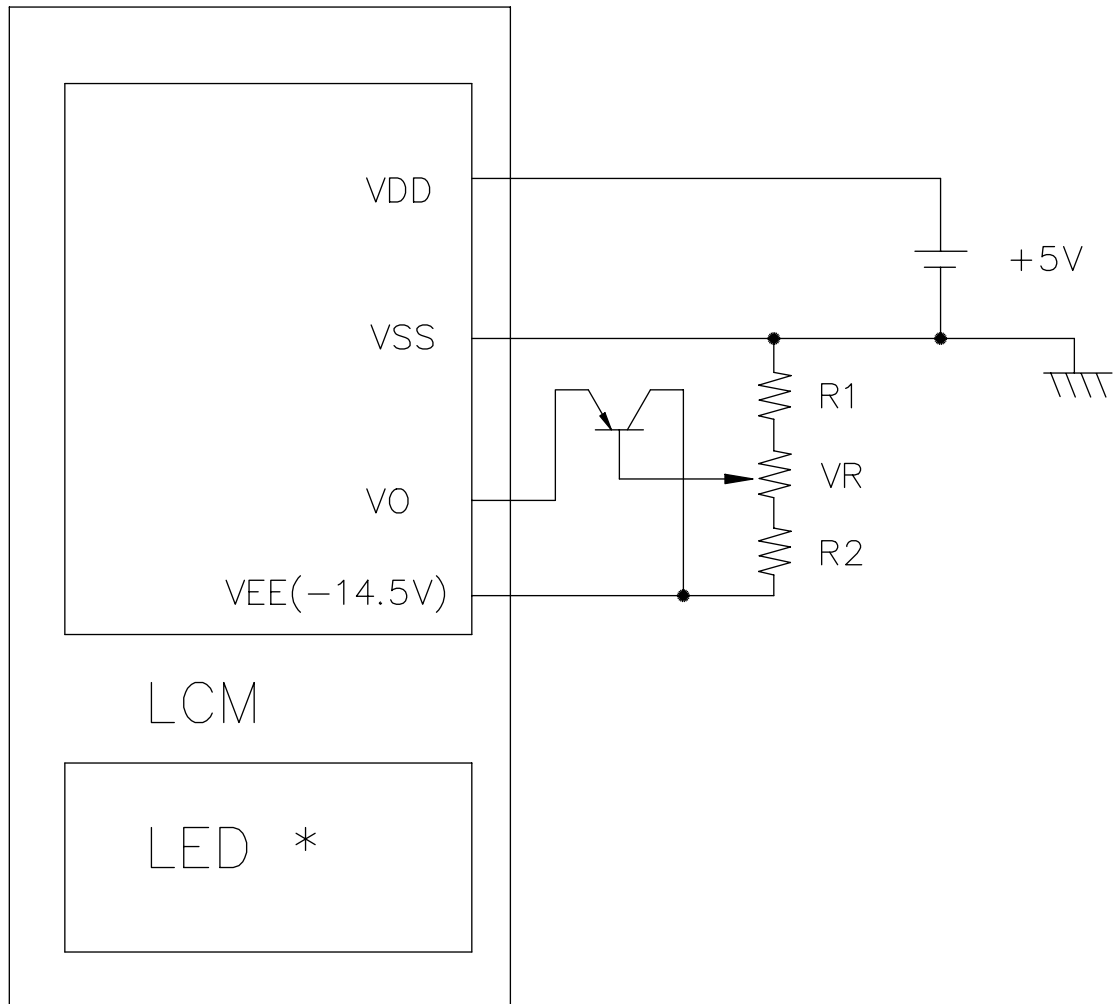

$$R1 + VR + R2 = 10K \sim 20K$$

\*: Power is internally supplied to LEDs.



# AZ Displays, Inc.

## 8. TIMING CHARACTERISTICS

### 8-1 INTERFACE TIMING

ITEM	ITEM	CONDITION	MIN.	MAX.	UNIT
C/ $\bar{D}$ SET UP TIME	$t_{CDS}$	Fig.	100	—	ns
C/ $\bar{D}$ HOLD TIME	$t_{CDH}$	Fig.	10	—	ns
$\bar{C}\bar{E}, \bar{R}\bar{D}, \bar{W}\bar{R}$ CLOCK WIDTH	$t_{CP}, t_{RP}, t_{WP}$	Fig.	80	—	ns
DATA SET UP TIME	$t_{DS}$	Fig.	80	—	ns
DATA HOLD TIME	$t_{DH}$	Fig.	40	—	ns
ACCESS TIME	$t_{ACC}$	Fig.	—	150	ns
DATA OUTPUT HOLD TIME	$t_{OH}$	Fig.	10	50	ns

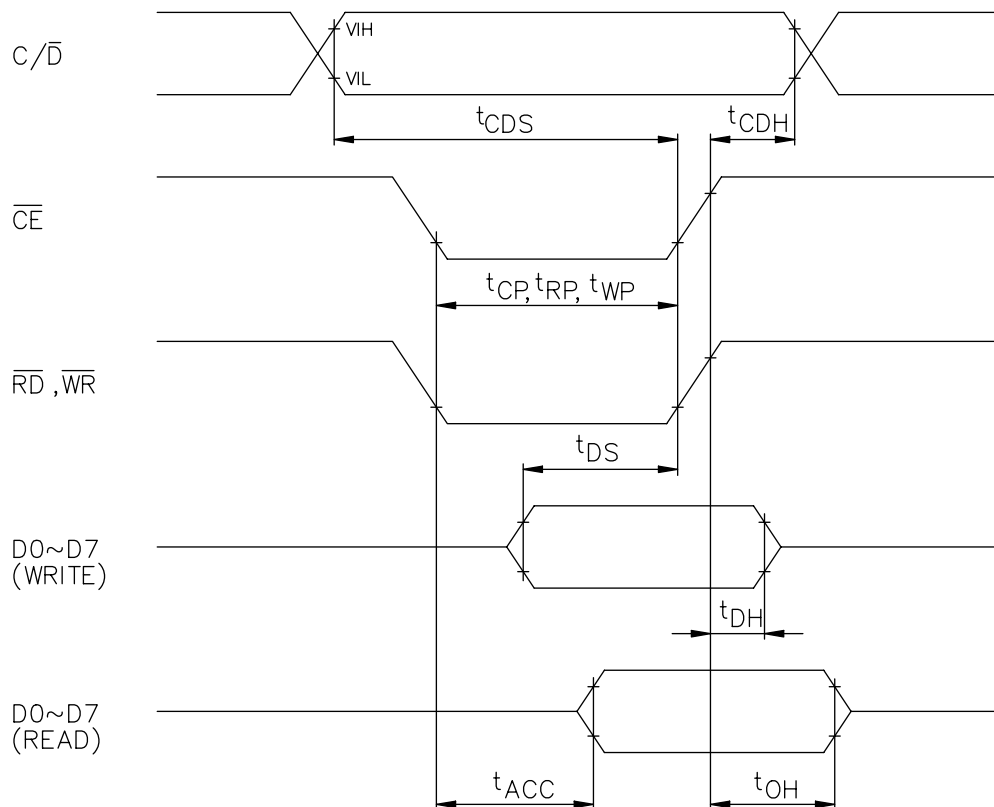
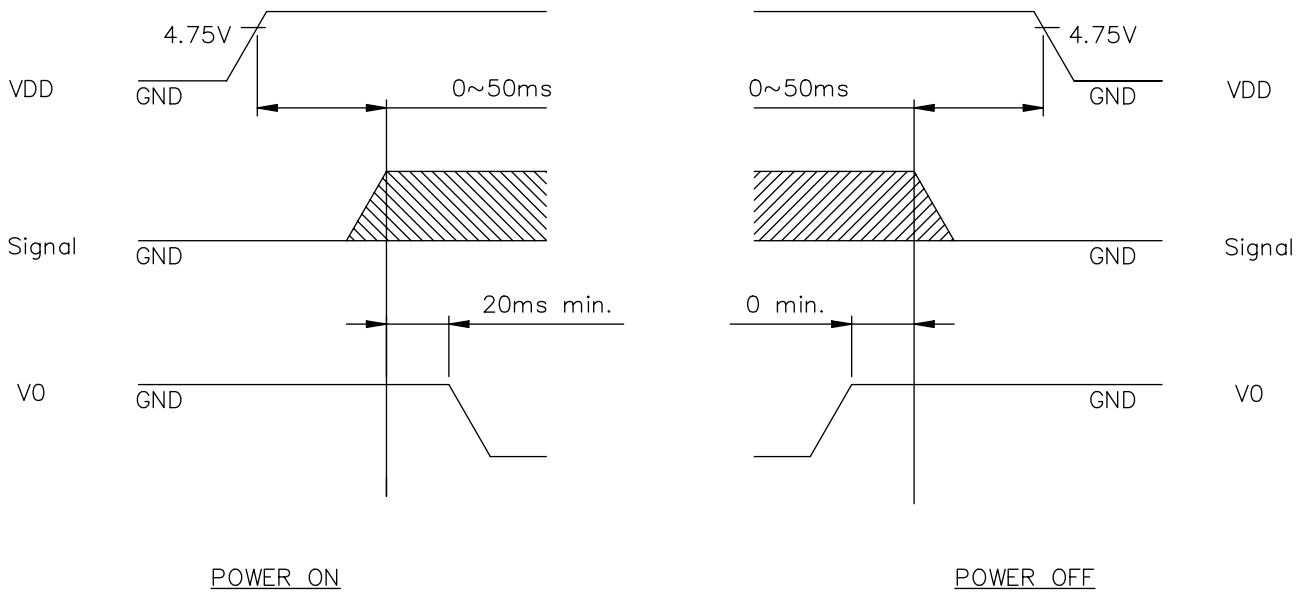

Fig. INTERFACE TIMING CHART

# AZ Displays, Inc.

## 8-2 POWER ON/OFF TIMING



THE RECOMMENDED POWER & INTERFACE TIMING SEQUENCE

## 9. DISPLAY PATTERN

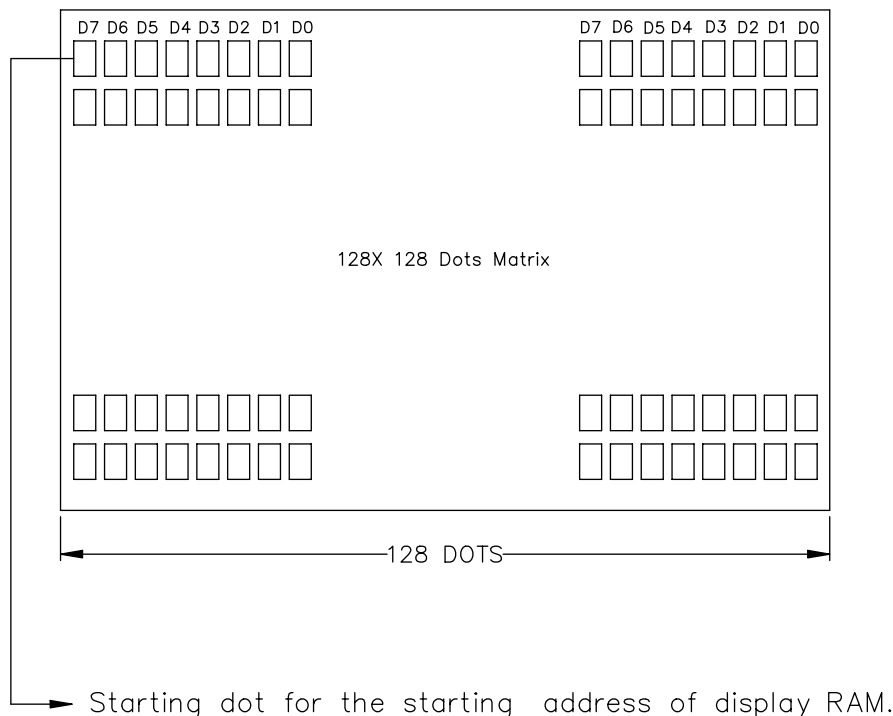

D0~D7 are 8 bits transmitted data ,where D0 is LSB and D7 is MSB.

# AZ Displays, Inc.

(NOTE 4)

Definition of Viewing Direction

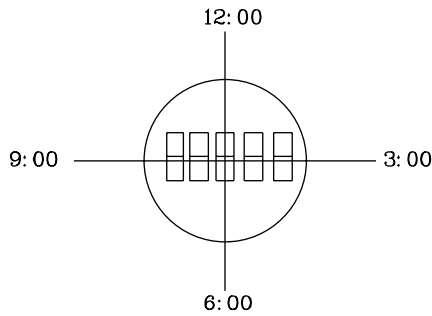

(NOTE 5)

Definition of Viewing Angle

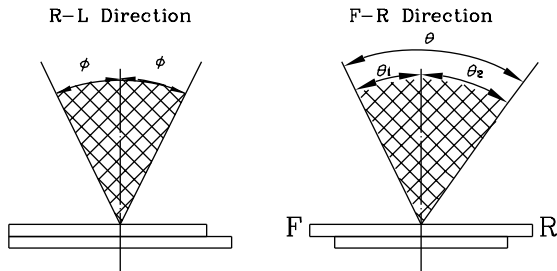

$$\theta = \theta_1 + \theta_2$$

\*Conditions

- Operating Voltage :  $V_{op}$
- Frame Frequency : 70Hz
- Applying Waveform : 1/N duty 1/a bias
- Contrast Ratio : larger than 2

(NOTE 6)

Definition of Contrast Ratio (Cr)

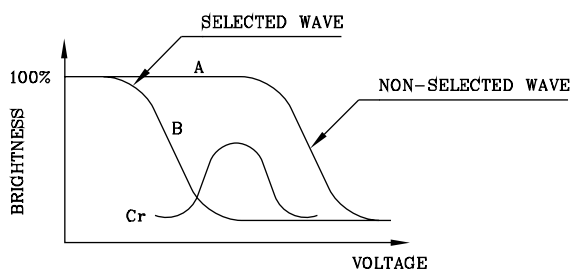

(positive type)

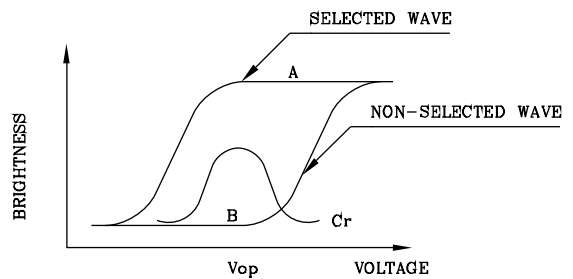

(negative type)

$$\text{Contrast Ratio : } Cr = A/B$$

\*Conditions

- Viewing Angle : 0
- Frame Frequency : 70Hz
- Applying Waveform : 1/N duty 1/a bias

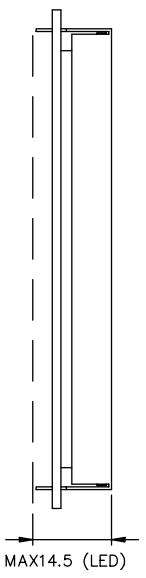
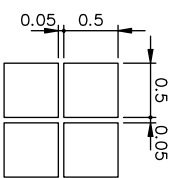
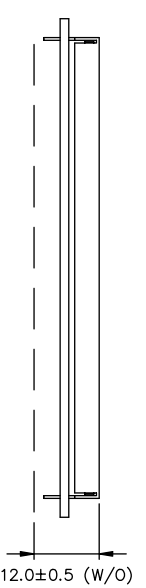
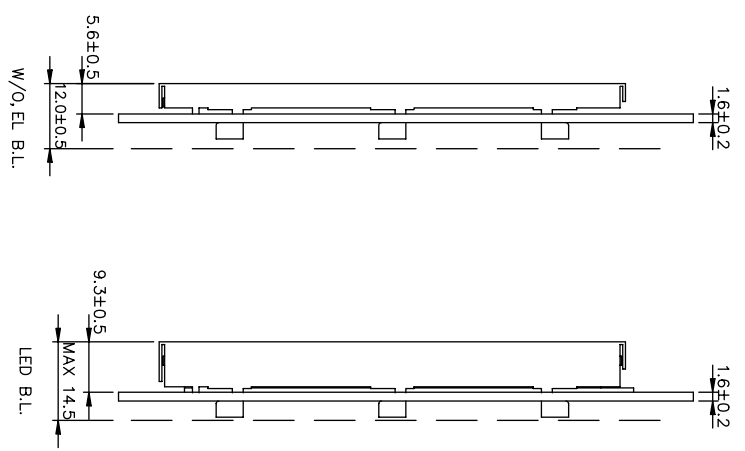
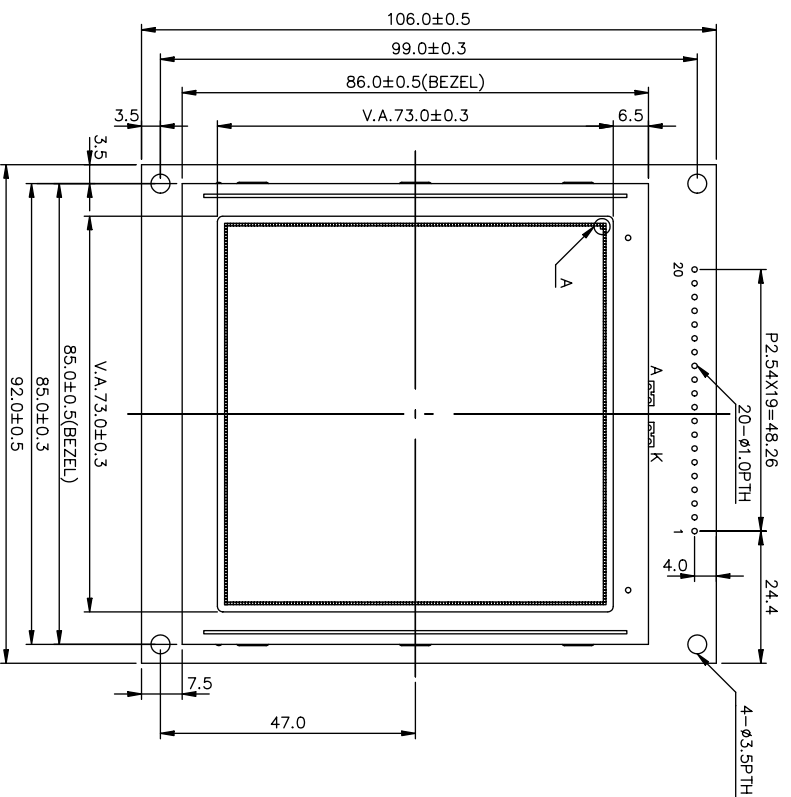

Note :

- 1.RESOLUTION : 128 X128
- 2.GENERAL TOLERANCE : ±0.5mm

No.	Symbol
1	FGND
2	GND
3	VDD
4	V0
5	WR
6	RD
7	CE
8	C/D
9	RST
10	DB0
11	DB1
12	DB2
13	DB3
14	DB4
15	DB5
16	DB6
17	DB7
18	FS
19	VEE
20	HALT

AGM1212D		AZ DISPLAYS, INC.	
NAME	DATE	TITLE	
APPROVE		DWG-NO	MX-X082X
CHECK		DESIGN	Rev.A
DESIGN		UNIT	mm
DRAW	MAY PING 86.11.07	SCALE	2/3
		THIRD ANGLE PROJECT	

128x128 DOTS  
A DETAIL