

Logic Diagram

FEATURES:

- All output pair skew < 100 ps typical (250 max.)
- 3.75 to 80 MHz output operation
- User-selectable output functions
- Selectable skew to 18 ns
- Inverted and non-inverted
- Operation at 1/2 and 1/4 input frequency
- Operation at 2x and 4x input frequency (input as low as 3.75 MHz)
- Zero input to output delay
- 50% duty-cycle outputs
- Outputs drive 50Ω terminated lines
- Low operating current
- Package: 32-pin RAD-PAK® flat package
- Jitter < 200 ps peak-to-peak (< 25 ps RMS)
- Compatible with Pentium™-based processor
- Total dose hardness:
 - >100 krad (Si), depending upon space mission
- Excellent Single Event Effects:
 - SEL > 116MeV/mg/cm²
 - SEU_{TH} -3 MeV/mg/cm²
 - SEU sat cross section: 1E-3/device

DESCRIPTION:

Maxwell Technologies' 7B991 Programmable Skew Clock Buffers (PSCB) offer user-selectable control over system clock functions. These multiple-output clock drivers provide the system integrator with functions necessary to optimize timing of high-performance computer systems. Eight individual drivers, arranged as four pairs of user-controllable outputs, can each drive terminated transmission lines with impedances as low as 50Ω while delivering minimal and specified output skews and full-swing logic levels.

Each output can be hardwired to one of nine delay or function configurations. Delay increments of 0.7 to 1.5 ns are determined by the operating frequency with outputs able to skew up to ± 6 time units from their nominal "zero" skew position. The completely integrated PLL allows external load and transmission line delay effects to be canceled. When this "zero delay" capability of the PSCB is combined with the selectable output skew functions, the user can create output-to-output delays of up to ±12 time units.

Maxwell Technologies' patented RAD-PAK® packaging technology incorporates radiation shielding in the microcircuit package. It eliminates the need for box shielding while providing the required radiation shielding for a lifetime in orbit or space mission. In a GEO orbit, RAD-PAK provides greater than 100 krad (Si) radiation dose tolerance. This product is available with screening up to Class S.

TABLE 1. 7B991 PINOUT DESCRIPTIONS

PIN	SYMBOL	I/O	DESCRIPTION
1	REF	I	Reference frequency input supplies the frequency and timing against which all functional variation is measured.
17	FB	I	PLL feedback (typically connected to one of the eight outputs)
3	FS	I	Three-level frequency range select. See Table 2.
26, 27	1F0, 1F1	I	Three-level function select inputs for output pair 1 (1Q0, 1Q1). See Table 2.
29, 30	2F0, 2F1	I	Three-level function select inputs for output pair 2 (2Q0, 2Q1). See Table 2.
4, 5	3F0, 3F1	I	Three-level function select inputs for output pair 3 (3Q0, 3Q1). See Table 2.
6, 7	4F0, 4F1	I	Three-level function select inputs for output pair 4 (4Q0, 4Q1). See Table 2.
31	TEST	I	Three-level select. See test mode section under the block diagram descriptions.
23, 24	1Q1, 1Q0	O	Output pair 1. See Table 2.
21, 22	2Q1, 2Q0	O	Output pair 2. See Table 2.
14, 15	3Q1, 3Q0	O	Output pair 3. See Table 2.
10, 11	4Q1, 4Q0	O	Output pair 4. See Table 2.
9, 16, 18, 25	V _{CCN}	PWR	Power supply for output drivers
2	V _{CCQ}	PWR	Power supply for internal circuitry
12, 13, 21, 22, 28, 32	GND	PWR	Ground.

TABLE 2. 7B991 ABSOLUTE MAXIMUM RATINGS

PARAMETER	SYMBOL	MIN	MAX	UNIT
Storage Temperature	T _S	-65	150	°C
Operating Temperature Range	T _A	-40	85	°C
Supply Voltage to Ground Potential	V _S	-0.5	7.0	V
DC Input Voltage	V _I	-0.5	7.0	V
Output Current into Outputs (LOW)	I _{OUT}	--	64	mA
Static Discharge Voltage (per MIL-STD-882, Method 3015)	V _{SD}	>2001	--	V
Latchup Current	I _{LU}	>200	--	mA

TABLE 3. DELTA LIMITS

PARAMETER	VARIATION
I_{CCQ}	±10% of specified value in Table 5
I_{CCN}	±10% of specified value in Table 5

TABLE 4. 7B991 RECOMMENDED OPERATING CONDITIONS

PARAMETER	SYMBOL	MIN	MAX	UNIT
Supply Voltage	V_{CC}	-0.5	+7.0	V
Input HIGH Voltage (REF and FB inputs only)	V_{IH}	2.0	V_{CC}	V
Input LOW Voltage (REF and FB inputs only)	V_{IL}	-0.5	0.8	V
Three-Level Input HIGH Voltage (Test, FS, xFn) ¹	V_{IHH}	$V_{CC}-0.85$	V_{CC}	V
Thermal Impedance	Θ_{JC}	--	3.43	°C/W

1. These inputs are normally wired to V_{CC} , GND, or left unconnected (actual threshold voltages vary as a percentage of V_{CC}). Internal termination resistors hold unconnected inputs at $V_{CC}/2$. If these inputs are switched, the function and timing of the outputs may glitch and the PLL may require an additional t_{LOCK} time before all datasheet limits are achieved.

TABLE 5. 7B991 DC ELECTRICAL CHARACTERISTICS

($V_{CC} = 5V \pm 10\%$, $T_A = -40$ TO $85^\circ C$, UNLESS OTHERWISE SPECIFIED)

PARAMETER	SYMBOL	TEST CONDITIONS	SUBGROUPS	MIN	MAX	UNIT
Output HIGH Voltage	V_{OH}	$V_{CC} = \text{Min}$, $I_{OH} = -16$ mA	1, 2, 3	2.4	--	V
Output LOW Voltage	V_{OL}	$V_{CC} = \text{Min}$, $I_{OL} = 46$ mA	1, 2, 3	--	0.45	V
Input HIGH Voltage (REF and FB inputs only)	V_{IH}		1, 2, 3	2.0	--	V
Input LOW Voltage (REF and FB inputs only)	V_{IL}		1, 2, 3	--	0.8	V
Three-Level Input HIGH Voltage (Test, FS, xFn) ¹	V_{IHH}	$\text{Min} \leq V_{CC} \leq \text{Max}$	1, 2, 3	$V_{CC}-0.85$	--	V
Three-Level Input MID Voltage (Test, FS, xFn) ¹	V_{IMM}	$\text{Min} \leq V_{CC} \leq \text{Max}$	1, 2, 3	$V_{CC}/2 - 500$ mV	$V_{CC}/2 + 500$ mV	V
Three-Level Input LOW Voltage (Test, FS, xFn) ¹	V_{ILL}	$\text{Min} \leq V_{CC} \leq \text{Max}$	1, 2, 3	0.0	0.85	V
Input HIGH Leakage Current (REF and FB inputs only)	I_{IH}	$V_{CC} = \text{Max}$, $V_{IN} = 5V$	1, 2, 3	--	10	μA
Input LOW Leakage Current (REF and FB inputs only)	I_{IL}	$V_{CC} = \text{Max}$, $V_{IN} = 0.4V$	1, 2, 3	-500	--	μA

TABLE 5. 7B991 DC ELECTRICAL CHARACTERISTICS
($V_{CC} = 5V \pm 10\%$, $T_A = -40$ TO $85^\circ C$, UNLESS OTHERWISE SPECIFIED)

PARAMETER	SYMBOL	TEST CONDITIONS	SUBGROUPS	MIN	MAX	UNIT
Input HIGH Current (Test, FS, xFn)	I_{IH}	$V_{IN} = V_{CC}$	1, 2, 3	--	200	μA
Input MID Current (Test, FS, xFn)	I_{IMM}	$V_{IN} = 2.75$	1, 2, 3	-200	200	μA
Input LOW Current (Test, FS, xFn)	I_{ILL}	$V_{IN} = GND$	1, 2, 3	--	-200	μA
Output Short Circuit (Test, FS, xFn) 2	I_{OS}	$V_{CC} = \text{Max.}, V_{OUT} = GND$ ($25^\circ C$ only)	1	--	-250	mA
Operating Current used by Internal Circuitry	I_{CCQ}	$V_{CCN} = V_{CCQ} = \text{Max}$, all input selects open	1, 2, 3	--	90	mA
Output Buffer Current per Output Pair 3	I_{CCN}	$V_{CCN} = V_{CCQ} = \text{Max}$, $I_{OUT} = 0$ mA, Input selects open, fMAX	1, 2, 3	--	14	mA
Power Dissipation per Output Pair 4	P_D	$V_{CCN} = V_{CCQ} = \text{Max}$, $I_{OUT} = 0$ mA Input selects open, fMAX	1, 2, 3	--	78	mW

1. These inputs are normally wired to V_{CC} , GND, or left unconnected (actual threshold voltages vary as a percentage of V_{CC}). Internal termination resistors hold unconnected inputs at $V_{CC}/2$. If these inputs are switched, the function and timing of the outputs may glitch and the PLL may require an additional t_{LOCK} time before all datasheet limits are achieved.

2. This device should be tested one output at a time, output shorted for less than one second, less than 10% duty cycle. Room temperature only.

3. Total output current per output pair can be approximated by the following expression that includes device current plus load current:

$$ICCN = [(4 + 0.11F) + [(835-3F)/Z] + (.0022FC)]N \times 1.1$$

Where:

f = frequency in MHz

C = capacitive load in pF

Z = line impedance in ohms

N = number of loaded outputs; 0, 1, or 2

FC = F * C

4. Total power dissipation per output pair can be approximated by the following expression that includes device power dissipation due to the load circuit:

$$PD = [(22 + 0.61F) + [(1550-2.7F)/Z] + (.0125FC)]N \times 1.1$$

TABLE 6. 7B991 CAPACITANCE¹

PARAMETER	SYMBOL	TEST CONDITIONS	MAX	UNIT
Input Capacitance	C_{IN}	$T_A = 25^\circ C$, f = 1 MHz, $V_{CC} = 5.0V$	10	pF

1. Guaranteed by design.

FIGURE 1. TTL AC TEST LOAD

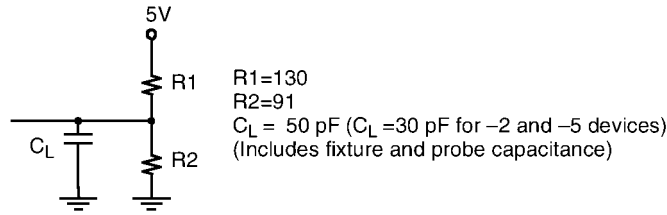

FIGURE 2. TTL INPUT TEST WAVEFORM

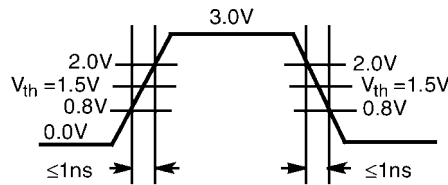

TABLE 7. AC ELECTRICAL CHARACTERISTICS ^{1,2,3}
 ($V_{CC} = 5V \pm 10\%$, $T_A = -40$ TO 85°C , UNLESS OTHERWISE SPECIFIED)

PARAMETER		SYMBOL	SUBGROUPS	MIN	TYP	MAX	UNIT
Operating Clock Frequency in MHz	FS = LOW ^{1,4}	f_{NOM}	9, 10, 11	15	--	30	MHz
	FS = MID ^{1,4}			25	--	50	
	FS = HIGH ^{1,4,5}			40	--	80	
REF Pulse Width HIGH		t_{RPWH}	9, 10, 11	5.0	--	--	ns
REF Pulse Width LOW		t_{RPWL}	9, 10, 11	5.0	--	--	ns
Programmable Skew Unit		t_U	9, 10, 11	See Table 2			
Zero Output Matched-Pair Skew (XQ0, XQ1) ^{6,7}		t_{SKEWPR}	9, 10, 11	--	0.1	0.50	ns
Zero Output Skew (All Outputs) ^{6,8,9}		t_{SKEW0}	9, 10, 11	--	0.3	0.75	ns
Output Skew (Rise-Rise, Fall-Fall, Same Class Outputs) ^{6,10}		t_{SKEW1}	9, 10, 11	--	0.6	1.0	ns
Output Skew (Rise-Fall, Nominal-Inverted, Divided-Divided) ^{6,10}		t_{SKEW2}	9, 10, 11	--	1.0	1.5	ns
Output Skew (Rise-Rise, Fall-Fall, Different Class Outputs) ^{6,10}		t_{SKEW3}	9, 10, 11	--	0.7	1.2	ns
Output Skew (Rise-Fall, Nominal-Divided, Divided-Inverted) ^{6,10}		t_{SKEW4}	9, 10, 11	--	1.2	1.7	ns
Device-to-Device Skew ^{1,11,12}		t_{DEV}	9, 10, 11	--	--	1.65	ns
Propagation Delay, REF Rise to FB Rise		t_{PD}	9, 10, 11	-1	0.0	1	ns
Output Duty Cycle Variation ¹³		t_{ODCV}	9, 10, 11	-1.2	0.0	1.2	ns

TABLE 7. AC ELECTRICAL CHARACTERISTICS ^{1,2,3}
 ($V_{CC} = 5V \pm 10\%$, $T_A = -40$ TO $85^\circ C$, UNLESS OTHERWISE SPECIFIED)

PARAMETER	SYMBOL	SUBGROUPS	MIN	TYP	MAX	UNIT
Output HIGH Time Deviation from 50% ^{14,15}	t_{PWH}	9, 10, 11	--	--	3	ns
Output LOW Time Deviation from 50% ^{14,15}	t_{PWL}	9, 10, 11	--	--	3.5	ns
Output Rise Time ^{14,16}	t_{ORISE}	9, 10, 11	0.15	1.5	2.5	ns
Output Fall Time ^{14,16}	t_{OFALL}	9, 10, 11	0.15	1.5	2.5	ns
PLL Lock Time ¹⁷	t_{LOCK}	9, 10, 11	--	--	0.5	ms
Cycle-to-Cycle Output Jitter	Peak-to-Peak ³	t_{JR}	9, 10, 11	--	200	ps

- The level to be set of FS is determined by the "normal" operating frequency (f_{NOM}) of the V_{CO} and Time Unit Generator (see Logic Block Diagram). Nominal frequency (f_{NOM}) always appears at 1Q0 and the other outputs when they are operated in their undivided modes (See Table 9). The frequency appearing at the REF and FB inputs will be f_{NOM} when the output connected to FB is undivided. The frequency of the REF and FB inputs will be $f_{NOM}/2$ or $f_{NOM}/4$ when the part is configured for a frequency multiplication by using a divided output as the FB input.
- Test measurement levels for the 7B991 are TTL levels (1.5V to 1.5V). Test conditions assume signal transition times of 2 ns or less and output loading as shown in the AC Test Loads and Waveforms unless otherwise specified.
- Guaranteed by statistical correlation. Tested initially and after any design or process changes that may affect these parameters.
- For all three state inputs. HIGH indicates a connection to V_{CC} , LOW indicates a connection to GND, and MID indicates an open connections. Internal termination circuitry holds an unconnected input to $V_{CC}/2$.
- When the FS pin is selected HIGH, the REF input must not transition upon power-up until V_{CC} has reached 4.3V.
- SKEW is defined as the time between the earliest and the latest output transition among all outputs for which the same t_U delay has been selected when all are loaded with 50 pF and terminated with 50Ω to 2.06V.
- t_{SKEWPR} is defined as the skew between a pair of outputs (XQ0 and XQ1) when all eight outputs are selected for $0t_U$.
- t_{SKEW0} is defined as the skew between outputs when they are selected for $0t_U$. Other outputs are divided or inverted but not shifted.
- $C_L = 0$ pF. For $C_L = 30$ pF, $t_{SKEW0} = 0.35$ ns.
- There are three classes of outputs: Nominal (multiple of t_U delay), Inverted (4Q0 and 4Q1 only with 4F0 = 4F1 = HIGH), and divided (3Qx and 4Qx only in Divide-by-2 or Divide-by-4 mode).
- t_{DEV} is the output-to-output skew between any two devices operating under the same conditions (V_{CC} ambient temperature, air flow, etc.)
- Guaranteed by design.
- t_{ODCV} is the deviation of the output from a 50% duty cycle. Output pulse width variations are included in t_{SKEW2} and t_{SKEW4} specifications.
- Specified with outputs loaded 30 pF for the 7B99 devices. Devices are terminated through 50Ω to 2.05V.
- t_{PWH} is measured at 2.0V. t_{PWL} is measured at 0.8V.
- t_{ORISE} and t_{OFALL} measured between 0.8V and 2.0V.
- t_{LOCK} is the time that is required before synchronization is achieved. This specification is valid only after V_{CC} is stable and within normal operating limits. This parameter is measured from the application of a new signal or frequency at REF or FB until t_{PD} is within specified limits.

FIGURE 3. AC TIMING DIAGRAMS

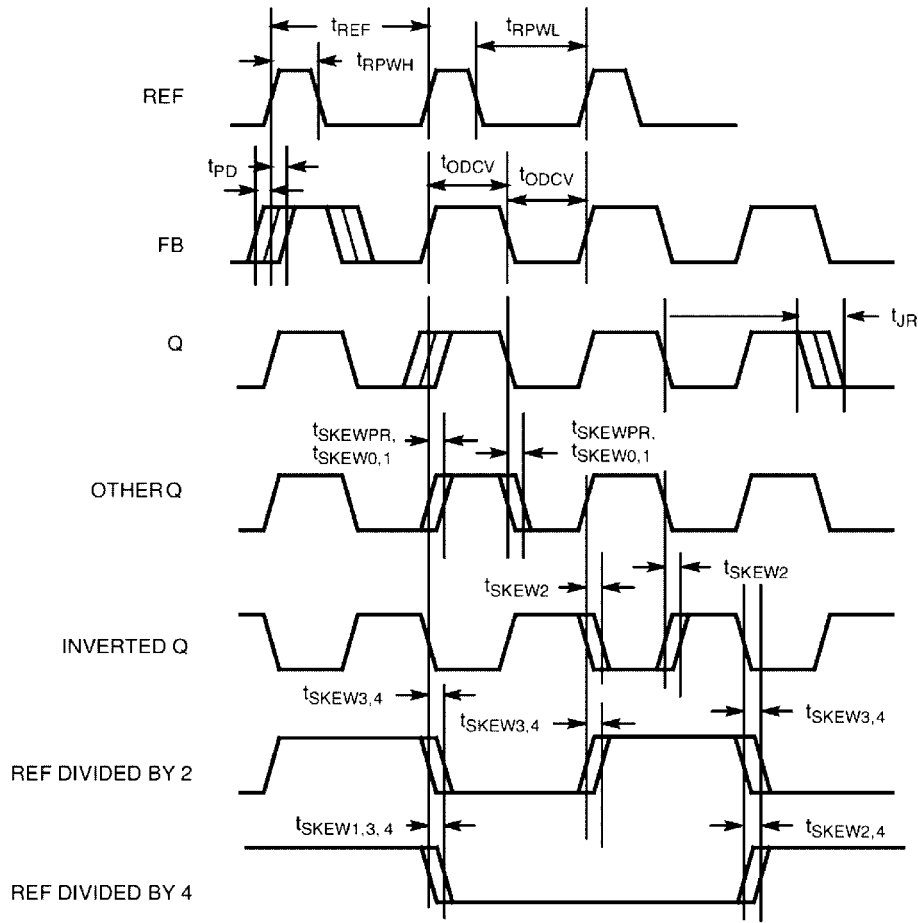

BLOCK DIAGRAM DESCRIPTION

Phase Frequency Detector and Filter

These two blocks accept inputs from the reference frequency (REF) input and the feedback (FB) input and generate correction information to control the frequency of the Voltage-Controlled Oscillator (VCO). These blocks, along with the VCO, form a Phase-Locked Loop (PLL) that tracks the incoming REF signal.

VCO and Time Unit Generator

The VCO accepts analog control inputs from the PLL filter block and generates a frequency that is used by the time unit generator to create discrete time units that are selected in the skew select matrix. The operational range of the VCO is determined by the FS control pin. The time unit (t_U) is determined by the operating frequency of the device and the level of the FS pin as shown in Table 1.

TABLE 8. 7B991 FREQUENCY RANGE SELECT AND t_U CALCULATION¹

FS ^{2,3}	fNOM (MHz)		$t_U = 1/f_{NOM} \times N$ WHERE N =	APPROXIMATE FREQUENCY (MHz) AT WHICH $t_U = 1.0$ ns
	MIN	MAX		
LOW	15	30	44	22.7
MID	25	50	26	38.5
HIGH	40	80	16	62.5

1. For all three state inputs, HIGH indicates a connection to V_{CC} . LOW indicates a connection to GND, and MID indicates an open connection. Internal termination circuitry holds an unconnected input to $V_{CC}/2$.
2. The level to be set of FS is determined by the "normal" operating frequency (f_{NOM}) of the V_{CO} and Time Unit Generator (see Logic Block Diagram). Nominal frequency (f_{NOM}) always appears at 1Q0 and the other outputs when they are operated in their undivided modes (See Table 9). The frequency appearing at the REF and FB inputs will be f_{NOM} when the output connected to FB is undivided. The frequency appearing at the REF and FB inputs will be $f_{NOM}/2$ or $f_{NOM}/4$ when the part is configured for a frequency multiplication by using a divided output as the FB input.
3. When the FS pin is selected HIGH, the REF input must not transition upon power-up until V_{CC} has reached 4.3V.

Skew Select Matrix

The skew select matrix is comprised of four independent sections. Each section has two low-skew, high-fanout drivers (xQ0, xQ1), and two corresponding three-level function select (xF0, xF1) inputs. Table 9 below shows the nine possible output functions for each section as determined by the function select inputs. All times are measured with respect to the REF input assuming that the output connected to the FB input has 0 t_U selected.

TABLE 9. 7B991 PROGRAMMABLE SKEW CONFIGURATIONS ¹

FUNCTION SELECTS		OUTPUT FUNCTIONS		
1F1, 2F1, 3F1, 4F1	1F0, 2F0, 3F0, 4F0	1Q0, 1Q1, 2Q0, 2Q1	3Q0, 3Q1	4Q0, 4Q1
LOW	LOW	-4t _U	Divide by 2	Divide by 2
LOW	MID	-3t _U	-6t _U	-6t _U
LOW	HIGH	-2t _U	-4t _U	-4t _U
MID	LOW	-1t _U	-2t _U	-2t _U
MID	MID	0t _U	0t _U	0t _U
MID	HIGH	+1t _U	+2t _U	+2t _U
HIGH	LOW	+2t _U	+4t _U	+4t _U
HIGH	MID	+3t _U	+6t _U	+6t _U
HIGH	HIGH	+4t _U	Divide by 4	Inverted

1. For all three state inputs. HIGH indicates a connection to V_{CC}. LOW indicates a connection to GND, and MID indicates an open connections. Internal termination circuitry holds an inconnected input to V_{CC}/2.

FIGURE 4. TYPICAL OUTPUTS WITH FB CONNECTED TO A ZERO-SKEW OUTPUT¹

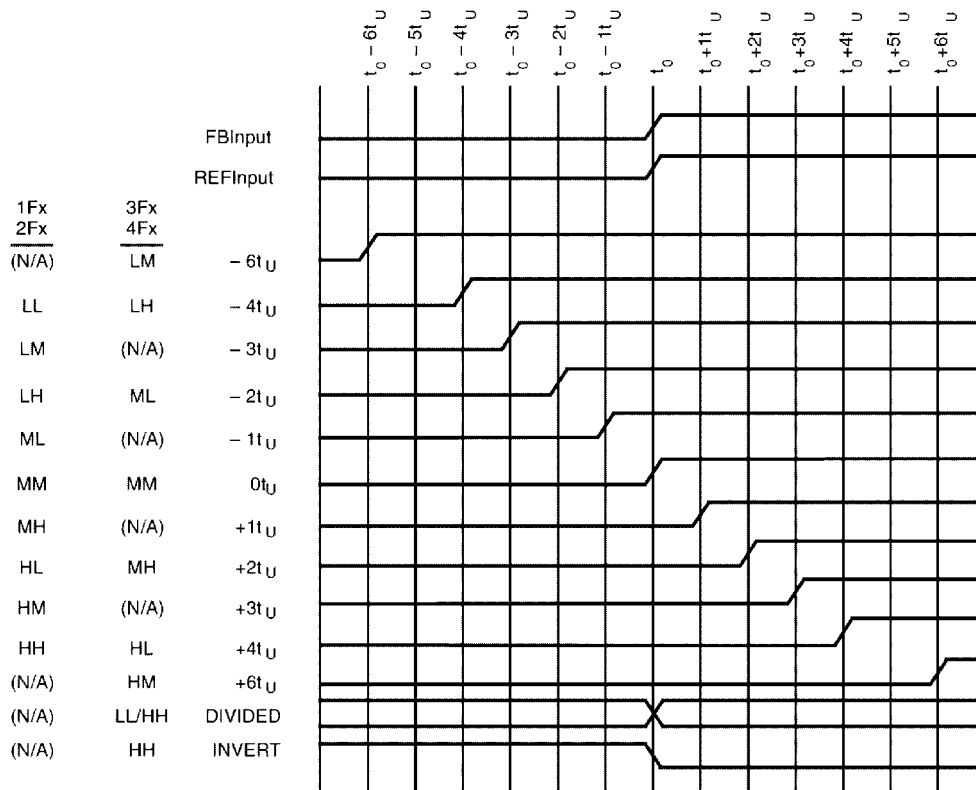

1. FB connected to an output selected for "zero" skew (i.e. xF1 = xF0 = MID)

Test Mode

The TEST input is a three-level input. In normal system operation, this pin is connected to ground, allowing the 7B991RP to operate as explained briefly above (for testing purposes, any of the three-level inputs can have a removable jumper to ground, or be tied LOW through a 100 Ω resistor. This will allow an external tester to change the state of these pins.)

If the TEST input is forced to its MID or HIGH state, the device will operate with its internal phase locked loop disconnected, and input levels supplied to REF will directly control all outputs. Relative output to output functions are the same as in normal mode.

In contrast with normal operation (TEST tied LOW). All outputs will function based only on the connection of their own function select inputs (xF0 and xF1) and the waveform characteristics of the REF input.

OPERATIONAL MODE DESCRIPTIONS

FIGURE 5. ZERO-SKEW AND/OR ZERO-DELAY CLOCK DRIVER

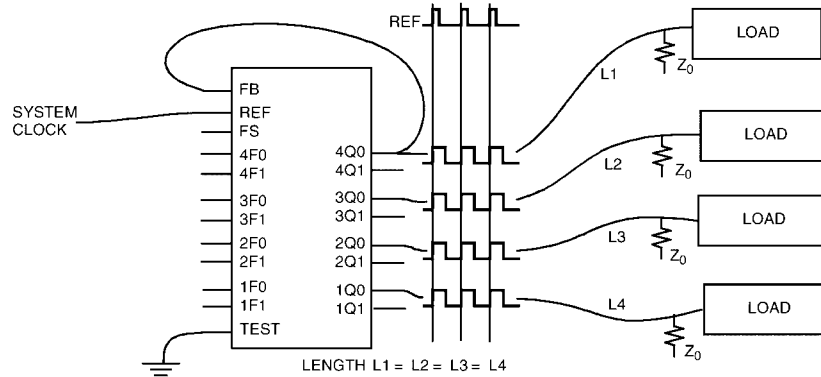

Figure 5 shows the PSCB configured as a zero-skew clock buffer. In this mode, the 7B991 can be used as the basis for a low-skew clock distribution tree. When all of the function select inputs (xFO, xF1) are left open, the outputs are aligned and may each drive a terminated transmission line to an independent load. The FB input can be tied to any output in this configuration and the operating frequency range is selected with the FS pin. The low-skew specification, coupled with the ability to drive terminated transmission lines (with impedances as low as 50 Ω), allow efficient printed circuit board design.

FIGURE 6. PROGRAMMABLE-SKEW CLOCK DRIVE

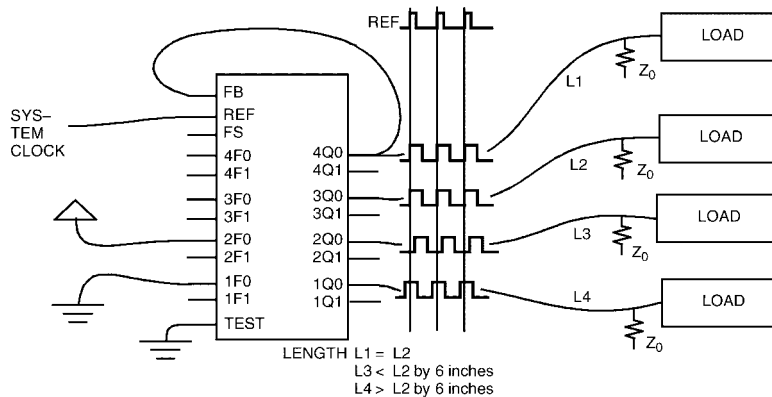

Figure 6 shows a configuration to equalize skew between metal traces of different lengths. In addition to low skew between outputs, the PSCB can be programmed to stagger the timing of its outputs. The four groups of output pairs can each be programmed to different output timing. Skew timing can be adjusted over a wide range in small increments with the appropriate strapping of the function select pins. In this configuration, the 4Q0 output is fed back to FB and configured for zero skew. The other three pairs of outputs are programmed to yield different skews relative to the feedback. By advancing the clock signal on the longer traces or retarding the clock signal on shorter traces, all loads can receive the clock pulse at the same time.

In this illustration, the FB input is connected to an output with 0-ns skew (xF1, xF0 = MID) selected. The internal PLL synchronizes the FB and REF inputs and aligns their rising edges to insure that all outputs have precise phase alignment.

Clock skews can be advanced by ± 6 time units (t_U) when using an output selected for zero skew as the feedback. A wider range of delays is possible if the output connected to FB is also skewed. Since "Zero Skew", $+t_U$ and $-t_U$ are defined relative to output groups, and since the PLL aligns the rising edges of REF and FB, it is possible to create wider output skews by proper selection of the xFn inputs. For example, a $+10 t_U$ between REG and 3Qx can be achieved by connecting 1Q0 to FB and setting 1F0 = 1F1 = GND, 3F0 = MID, and 3F1 = HIGH (Since FB aligns at $-4 t_U$ and 3Qx skews to $+6 t_U$, a total of $+10 t_U$ skew is realized.). Many other configurations can be realized by skewing both the output used as the FB input and skewing the other outputs.

FIGURE 7. INVERTED OUTPUT CONNECTIONS

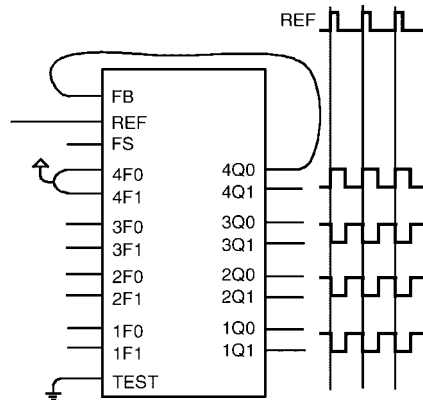

Figure shows an example of the invert function of the PSCB. In this example the 4Q0 output used as the FB input is programmed for invert (4F0 = 4F1 = HIGH) while the other three pairs of outputs are programmed for zero skew. When 4F0 and 4F1 are tied high, 4Q0 and 4Q1 become inverted zero phase outputs. The PLL aligns the rising edge of the FB input with the rising edge of the REF. This causes the 1Q, 2Q, and 3Q outputs to become the "inverted" outputs with respect to the REF input. By selecting which output connects to FB, it is possible to have 2 inverted and 6 non-inverted output or 6 inverted and 2 non-inverted outputs. The correct configuration would be determined by the need for more (or fewer) inverted outputs. 1Q, 2Q, and 3Q outputs can also be skewed to compensate for varying trace delays independent of inversion on 4Q.

FIGURE 8. FREQUENCY MULTIPLIER WITH SKEW CONNECTIONS

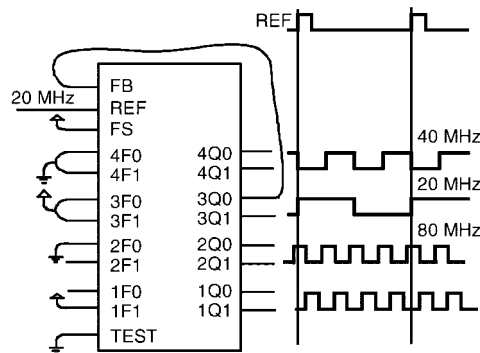

Figure illustrates the PSCB configured as a clock multiplier. The 3Q0 output is programmed to divide by four and is fed back to FB. This causes the PLL to increase its frequency until the 3Q0 and 3Q1 outputs are locked at 20 MHz while the 1Qx and 2Qx outputs run at 80 MHz. The 4Q0 and 4Q1 outputs are programmed to divide by two, which

results in a 40 MHz waveform at these outputs. Note that the 20 and 40 MHz clocks fall simultaneously and are out of phase on their rising edge. This will allow the designer to use the rising edges of the $\frac{1}{2}$ frequency and $\frac{1}{4}$ frequency outputs without concern for rising-edge skew. The 2Q0, 2Q1, 1Q0, and 1Q1 outputs run at 80 MHz and are skewed by programming their select inputs accordingly. Note that the FS pin is wired for 80 MHz operation because that is the frequency of the fastest output.

FIGURE 9. FREQUENCY DIVIDER CONNECTIONS

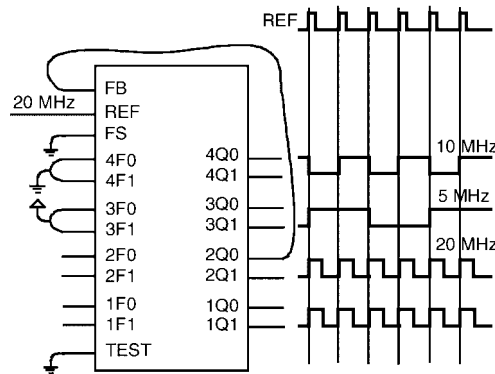

Figure demonstrates the PSCB in a clock divider application. 2Q0 is fed back to the FB input and programmed for zero skew. 3Qx is programmed to divide by four. 4Qx is programmed to divide by two. Note that the falling edges of the 4Qx and 3Qx outputs are aligned. This allows use of the rising edges of the $\frac{1}{2}$ frequency and $\frac{1}{4}$ frequency without concern for skew mismatch. The 1Qx outputs are programmed to zero skew and are aligned with the 2Qx outputs. In this example, the FS input is grounded to configure the device in the 15 to 30 MHz range since the highest frequency output is running at 20 MHz.

FIGURE 10. MULTI-FUNCTION CLOCK DRIVER

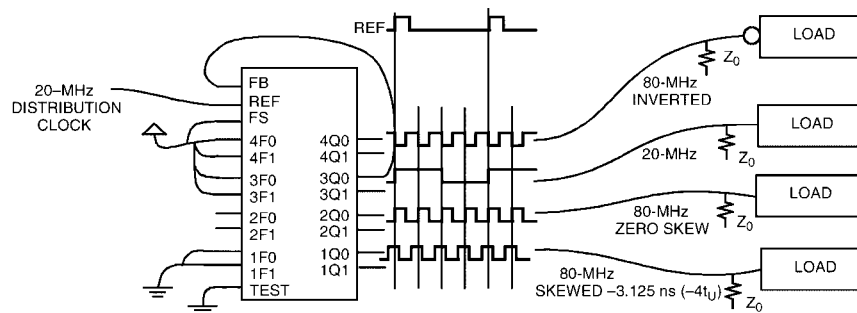

Figure shows some of the functions that are selectable on the 3Qx and 4Qx outputs. These include inverted outputs and outputs that offer divide-by-2 and divide-by-4 timing. An inverted output allows the system designer to clock different sub-systems on opposite edges, without suffering from the pulse asymmetry typical of non-ideal loading. This function allows the two subsystems to each be clocked 180 degrees out of phase, but still to be aligned within the skew specification.

The divided outputs offer a zero-delay divider for portions of the system that need the clock to be divided by either two or four, and still remain within a narrow skew of the "1X" clock. Without this feature, an external divider would need to be added, and the propagation delay of the divider would add to the skew between the different clock signals.

These divided outputs, coupled with the Phase Locked Loop, allow the PSCB to multiply the clock rate at the REF input by either two or four. This mode will enable the designer to distribute a low-frequency clock between various portions of the system, and then locally multiply the clock rate to a more suitable frequency, while still maintaining the low-skew characteristics described above at the same time. It can multiply by two and four or divide by two (and four) at the same time that it is shifting its outputs over a wide range or maintaining zero skew between selected outputs.

FIGURE 11. BOARD-TO-BOARD CLOCK DISTRIBUTION

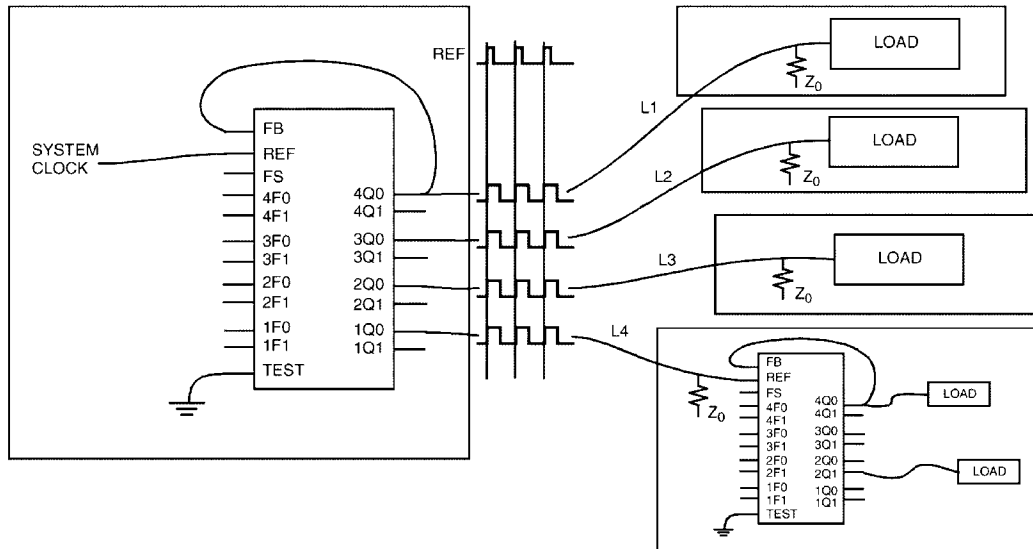
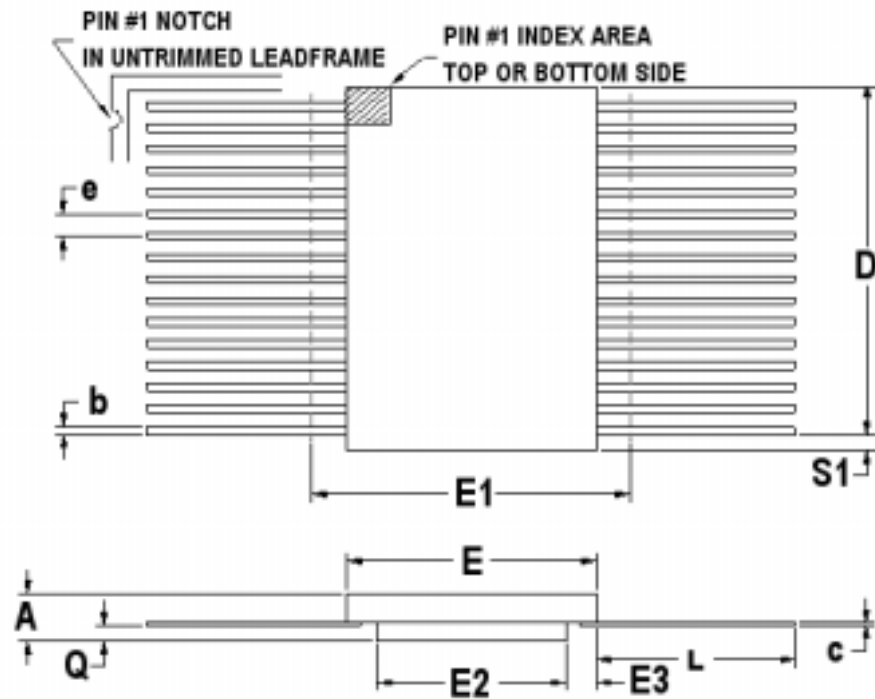

Figure shows the 7B991 connected in series to construct a zero-skew clock distribution tree between boards. Delays of the downstream clock buffers can be programmed to compensate for the wire length (i.e. select negative skew equal to the wire delay) necessary to connect them to the master clock source, approximating a zero-delay clock tree. Cascaded clock buffers will accumulate low-frequency jitter because of the non-ideal filtering characteristics of the PLL filter. It is recommended that not more than two clock buffers be connected in series.



32 PIN RAD-PAK® FLAT PACKAGE

SYMBOL	DIMENSION		
	MIN	NOM	MAX
A	0.117	0.130	0.163
b	0.015	0.017	0.022
c	0.004	0.005	0.009
D	--	0.820	0.830
E	0.404	0.410	0.416
E1	--	--	0.440
E2	0.234	0.240	--
E3	0.030	0.085	--
e	0.050 BSC		
L	0.350	0.370	0.390
Q	0.020	0.033	0.036
S1	0.005	0.027	--
N	32		

F32-01

Note: All dimensions in inches

Important Notice:

These data sheets are created using the chip manufacturer's published specifications. Maxwell Technologies verifies functionality by testing key parameters either by 100% testing, sample testing or characterization.

The specifications presented within these data sheets represent the latest and most accurate information available to date. However, these specifications are subject to change without notice and Maxwell Technologies assumes no responsibility for the use of this information.

Maxwell Technologies' products are not authorized for use as critical components in life support devices or systems without express written approval from Maxwell Technologies.

Any claim against Maxwell Technologies must be made within 90 days from the date of shipment from Maxwell Technologies. Maxwell Technologies' liability shall be limited to replacement of defective parts.

Programmable Skew Clock Buffer (PSCB)

7B991

Product Ordering Options

