

Typical Applications

- GSM Handsets
- CDMA Handsets
- TDMA Handsets
- IF or RF Buffer Amplifiers
- Driver Stage for Power Amplifiers
- Oscillator Loop Amplifiers

Product Description

The RF2371 is a general purpose, low-cost, high performance low noise amplifier designed for operation from a 2.7V to 4V supply with low current consumption. The attenuation of the device is controlled when in power down mode, providing a known gain step. The RF2371 is available in a small industry-standard SOT23-8 surface mount package, enabling compact designs which conserve board space. The design features a highly accurate PTAT (Proportional To Absolute Temperature) biasing scheme using bandgap cells.

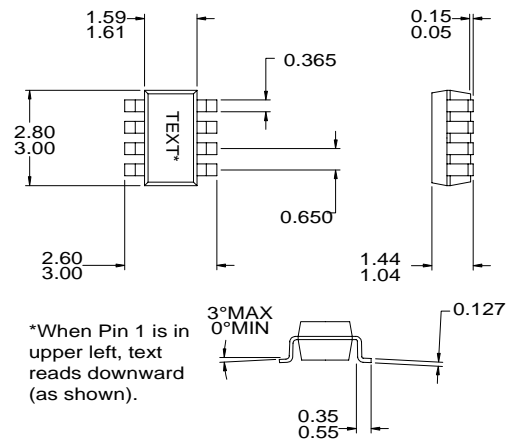

4
GENERAL PURPOSE AMPLIFIERS

Optimum Technology Matching® Applied

- | | | |
|--|-----------------------------------|--------------------------------------|
| <input type="checkbox"/> Si BJT | <input type="checkbox"/> GaAs HBT | <input type="checkbox"/> GaAs MESFET |
| <input checked="" type="checkbox"/> Si Bi-CMOS | <input type="checkbox"/> SiGe HBT | <input type="checkbox"/> Si CMOS |

Package Style: SOT23-8

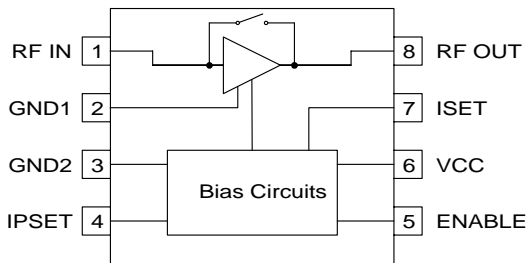

Functional Block Diagram

- Features
- 700MHz to 2000MHz Operation
 - 2.7V to 3.6V Single Supply
 - +5dBm Input IP₃ at 3.0mA
 - 12dB Gain at 1950MHz
 - 1.8dB Noise Figure at 1950MHz
 - 17dB Gain Step

Ordering Information

| | |
|-------------|----------------------------------|
| RF2371 | 3V Low Noise Amplifier |
| RF2371 PCBA | Fully Assembled Evaluation Board |

RF Micro Devices, Inc.
7625 Thorndike Road
Greensboro, NC 27409, USA

Tel (336) 664 1233
Fax (336) 664 0454
<http://www.rfmd.com>

Absolute Maximum Ratings

| Parameter | Rating | Unit |
|-------------------------------|-------------|------|
| Supply Voltage | 4.0 | V |
| Supply Current | 20 | mA |
| Operating Ambient Temperature | -40 to +85 | °C |
| Storage Temperature | -40 to +150 | °C |



Caution! ESD sensitive device.

RF Micro Devices believes the furnished information is correct and accurate at the time of this printing. However, RF Micro Devices reserves the right to make changes to its products without notice. RF Micro Devices does not assume responsibility for the use of the described product(s).

4

GENERAL PURPOSE
AMPLIFIERS

| Parameter | Specification | | | Unit | Condition |
|-------------------------------|---------------|-------------|-------|------|--|
| | Min. | Typ. | Max. | | |
| Overall | | | | | T=27°C, V _{CC} =2.7V, V _{ISELECT} =0V, V _{ENABLE} =2.7V |
| Frequency Range | | 700 to 2000 | | MHz | |
| LNA Performance | | | | | Freq=1.95GHz |
| Gain | 10.5 | 12.5 | | dB | |
| Noise Figure | | 1.6 | | dB | |
| Input IP3 | +4 | +6 | | dBm | At 2.9mA |
| Input P1dB | | -14 | | dBm | |
| Input VSWR | | 5:1 | | dB | (Noise match) |
| Output VSWR | | | 1.5:1 | dB | |
| Off Mode Gain | | -5.0 | | dB | V _{ENABLE} =0V |
| Gain | | 17 | | dB | Freq=836MHz |
| Noise Figure | | 1.6 | | dB | |
| Input IP3 | | 0 | | dBm | |
| Current Control | | | | | |
| Internal Current Setting "ON" | | CMOS Low | | V | Voltage on ISELECT |
| External Current Setting "ON" | | CMOS High | | V | Voltage on ISELECT |
| Current into ISELECT | | | 1 | µA | V _{ISELECT} =2.7V |
| Power Control | | | | | |
| Power "ON" Voltage | | CMOS High | | V | Voltage on ENABLE |
| Power "OFF" Voltage | | CMOS Low | | V | Voltage on ENABLE |
| Current into ENABLE | | | 1 | µA | V _{ENABLE} =2.7V |
| Power Supply | | | | | |
| Operating Voltage | | 2.7 to 3.6 | | V | |
| Operating Current | | 2.9 | 5 | mA | V _{CC} =2.7V, Internal current setting |
| Leakage Current | | | 1 | µA | V _{ENABLE} =0V |

| Pin | Function | Description | Interface Schematic |
|-----|---------------|---|---------------------|
| 1 | RF IN | RF input pin. This pin is not internally DC blocked and requires an external blocking capacitor. | |
| 2 | GND1 | Ground connection for the LNA. Keep traces physically short and connect immediately to ground plane for best performance. | |
| 3 | GND2 | Ground connection for the bias circuits. | |
| 4 | IPSET | This pin selects the internal current setting when CMOS level "low", and the external current setting when this pin is CMOS level "high". | |
| 5 | ENABLE | Power down control. This is a CMOS input. When this pin is CMOS "high" the device is enabled. When the level is CMOS "low" the device is shut off and a controlled attenuator is turned on. | |
| 6 | VCC | Power supply for the bias circuits. | |
| 7 | ISET | This pin sets the current for the device. | |
| 8 | RF OUT | RF output pin. Bias for the LNA is provided through this pin, hence it should be connected to VCC through an inductor. | |

Application Information

The RF2371 may be configured to use either the internal current setting or the external current setting. This choice is made by asserting IPSET, pin 4, to CMOS level “low” for the internal current setting or CMOS level “high” for the external current setting.

Internal Current Setting

When IPSET is set to CMOS “low”, the internal current settings are chosen. This current draw is typically 2.9mA. In this mode, the resistor R1 may be removed from the evaluation board schematic and ISET left floating. The condition for optimal IP3 is to use the internal current setting option and leave the ISET pin open (no connect).

External Current Setting

The external current setting is configured by using the series resistor between ISET, pin7, and ground (refer to resistor R1 in evaluation board schematic). The value of the resistor may be changed to permit various operating currents up to a maximum allowable current of 20mA. The table below gives approximate minimum R1 values to allow the 20mA maximum current draw at various operating voltages.

Note: When the internal current setting was selected, the part tested drew 4.4mA, which is higher than typical (2.9mA). Thus values of R1 given vary from part to part.

| V_{CC} (V) | Resistor R1 (Ω) | Current Draw (mA) |
|--------------|--------------------------|-------------------|
| 2.7 | 2.4k | 20.1 |
| 3.0 | 2.7k | 20.1 |
| 3.3 | 3.0k | 20.0 |
| 3.6 | 3.3k | 19.8 |

Application Schematic 1.95GHz

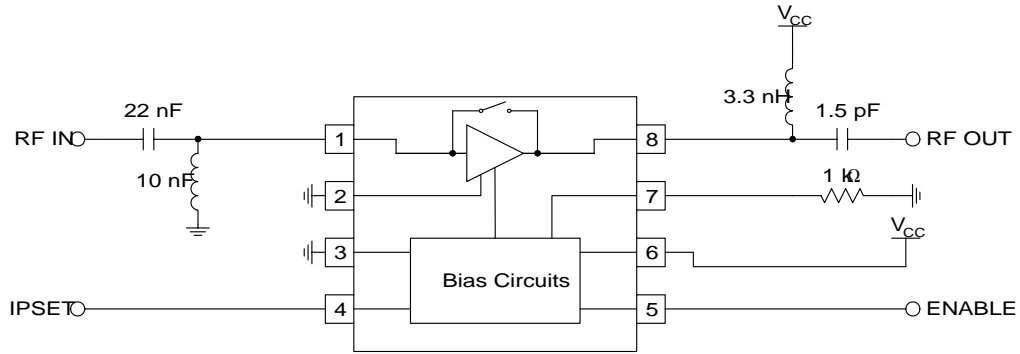

Application Schematic 836MHz

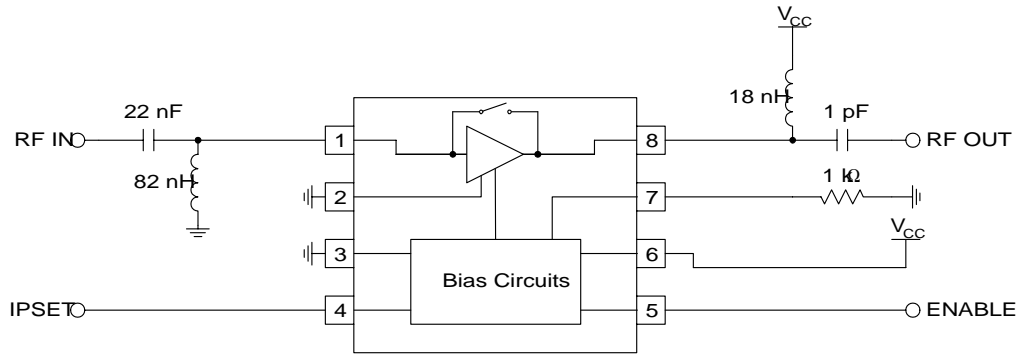

Evaluation Board Schematic

(Download [Bill of Materials](http://www.rfmd.com) from www.rfmd.com.)

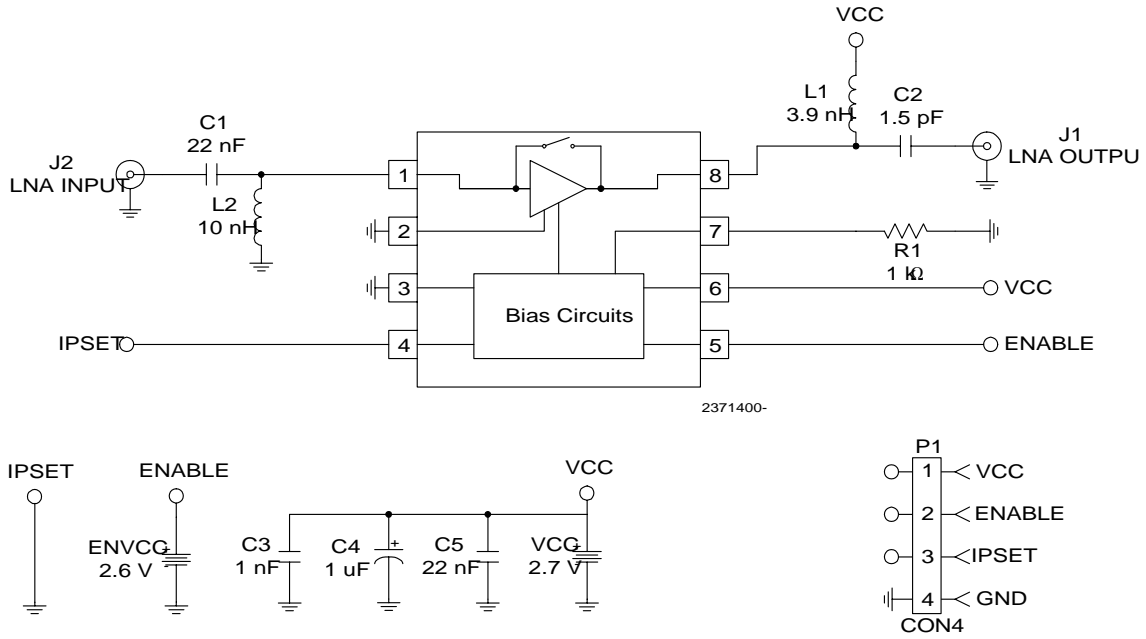

4
GENERAL PURPOSE
AMPLIFIERS

Evaluation Board Layout
Board Size 0.833" x 1.009"
Board Thickness 0.031", Board Material FR-4

