

**HEX BUFFER/LINE DRIVER; 3-STATE**

**FEATURES**

- Non-inverting outputs
- Output capability: bus driver
- I<sub>CC</sub> category: MSI

**GENERAL DESCRIPTION**

The 74HC/HCT365 are high-speed Si-gate CMOS devices and are pin compatible with low power Schottky TTL (LSTTL). They are specified in compliance with JEDEC standard no. 7A.

The 74HC/HCT365 are hex non-inverting buffer/line drivers with 3-state outputs. The 3-state outputs (nY) are controlled by the output enable inputs ( $\overline{OE}_1, \overline{OE}_2$ ).

A HIGH on  $\overline{OE}_n$  causes the outputs to assume a high impedance OFF-state.

The "365" is identical to the "366" but has non-inverting outputs.

SYMBOL	PARAMETER	CONDITIONS	TYPICAL		UNIT
			HC	HCT	
t <sub>PHL</sub> / t <sub>PLH</sub>	propagation delay nA to nY	C <sub>L</sub> = 15 pF V <sub>CC</sub> = 5 V	9	11	ns
C <sub>I</sub>	input capacitance		3,5	3,5	pF
C <sub>PD</sub>	power dissipation capacitance per buffer	notes 1 and 2	40	40	pF

GND = 0 V; T<sub>amb</sub> = 25 °C; t<sub>r</sub> = t<sub>f</sub> = 6 ns

**Notes**

1. C<sub>PD</sub> is used to determine the dynamic power dissipation (P<sub>D</sub> in μW):

$$P_D = C_{PD} \times V_{CC}^2 \times f_i + \Sigma (C_L \times V_{CC}^2 \times f_o)$$

f<sub>i</sub> = input frequency in MHz                      C<sub>L</sub> = output load capacitance in pF  
 f<sub>o</sub> = output frequency in MHz                    V<sub>CC</sub> = supply voltage in V  
 Σ (C<sub>L</sub> × V<sub>CC</sub><sup>2</sup> × f<sub>o</sub>) = sum of outputs

2. For HC the condition is V<sub>I</sub> = GND to V<sub>CC</sub>  
 For HCT the condition is V<sub>I</sub> = GND to V<sub>CC</sub> - 1.5 V

**PACKAGE OUTLINES**

16-lead DIL; plastic (SOT38Z).

16-lead mini-pack; plastic (SO16; SOT109A).

**PIN DESCRIPTION**

PIN NO.	SYMBOL	NAME AND FUNCTION
1, 15	$\overline{OE}_1, \overline{OE}_2$	output enable inputs (active LOW)
2, 4, 6, 10, 12, 14	1A to 6A	data inputs
3, 5, 7, 9, 11, 13	1Y to 6Y	data outputs
8	GND	ground (0 V)
16	V <sub>CC</sub>	positive supply voltage

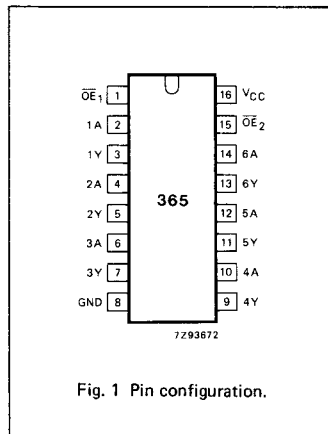

Fig. 1 Pin configuration.

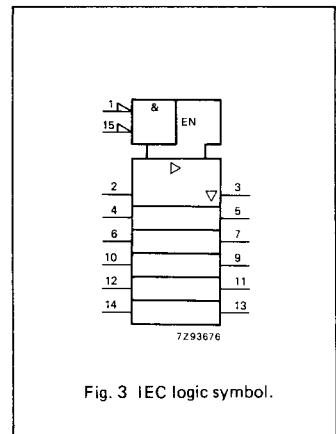
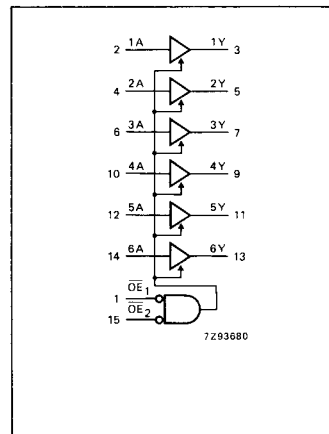

Fig. 3 IEC logic symbol.

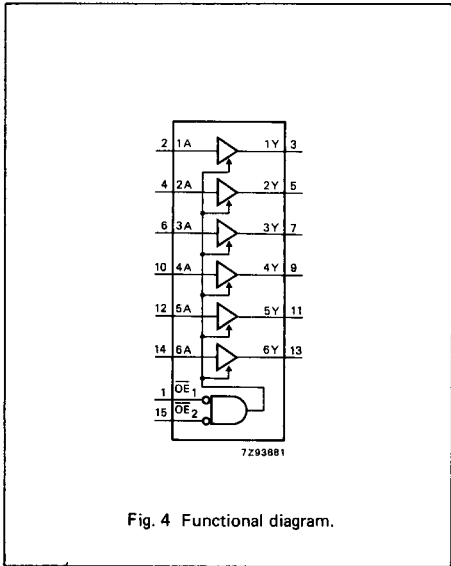

Fig. 4 Functional diagram.

FUNCTION TABLE

INPUTS			OUTPUT
$\overline{OE}_1$	$\overline{OE}_2$	nA	nY
L	L	L	L
L	L	H	H
X	H	X	Z
H	X	X	Z

H = HIGH voltage level  
L = LOW voltage level  
X = don't care  
Z = high impedance OFF-state

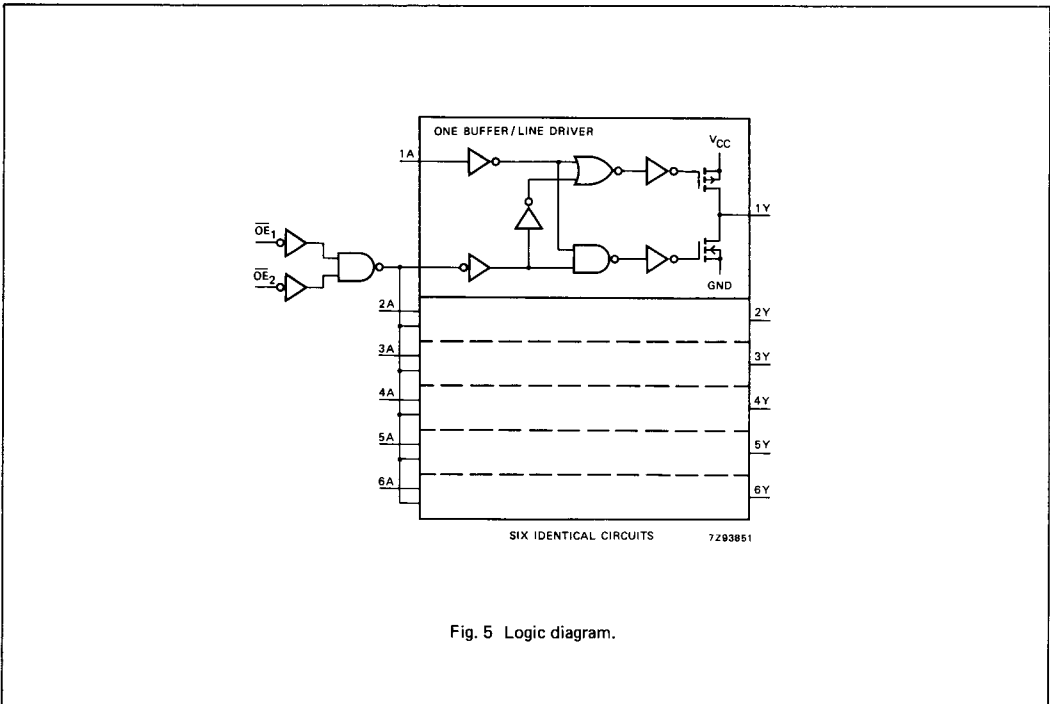

Fig. 5 Logic diagram.

**DC CHARACTERISTICS FOR 74HC**

For the DC characteristics see chapter "HCMOS family characteristics", section "Family specifications".

Output capability: bus driver

I<sub>CC</sub> category: MSI

**AC CHARACTERISTICS FOR 74HC**

GND = 0 V; t<sub>r</sub> = t<sub>f</sub> = 6 ns; C<sub>L</sub> = 50 pF

SYMBOL	PARAMETER	T <sub>amb</sub> (°C)						UNIT	TEST CONDITIONS		
		74HC							V <sub>CC</sub> V	WAVEFORMS	
		+25			-40 to +85		-40 to +125				
		min.	typ.	max.	min.	max.	min.				max.
t <sub>PHL</sub> / t <sub>PLH</sub>	propagation delay nA to nY		30 11 9	95 19 16		120 24 20		145 29 25	ns	2.0 4.5 6.0	Fig. 6
t <sub>PZH</sub> / t <sub>PZL</sub>	3-state output enable time OE <sub>n</sub> to nY		47 17 14	150 30 26		190 38 33		225 45 38	ns	2.0 4.5 6.0	Fig. 7
t <sub>PHZ</sub> / t <sub>PLZ</sub>	3-state output disable time OE <sub>n</sub> to nY		61 22 18	150 30 26		190 38 33		225 45 38	ns	2.0 4.5 6.0	Fig. 7
t <sub>THL</sub> / t <sub>TLH</sub>	output transition time		14 5 4	60 12 10		75 15 13		90 18 15	ns	2.0 4.5 6.0	Fig. 6

**DC CHARACTERISTICS FOR 74HCT**

For the DC characteristics see chapter "HCMOS family characteristics", section "Family specifications".

Output capability: bus driver

I<sub>CC</sub> category: MSI

**Note to HCT types**

The value of additional quiescent supply current (ΔI<sub>CC</sub>) for a unit load of 1 is given in the family specifications.

To determine ΔI<sub>CC</sub> per input, multiply this value by the unit load coefficient shown in the table below.

INPUT	UNIT LOAD COEFFICIENT
OE <sub>1</sub>	1.00
OE <sub>2</sub>	0.90
nA	1.00

AC CHARACTERISTICS FOR 74HCT

GND = 0 V;  $t_r = t_f = 6$  ns;  $C_L = 50$  pF

SYMBOL	PARAMETER	$T_{amb}$ (°C)						UNIT	TEST CONDITIONS		
		74HCT							$V_{CC}$ V	WAVEFORMS	
		+25			-40 to +85		-40 to +125				
		min.	typ.	max.	min.	max.	min.				max.
$t_{PHL}/t_{PLH}$	propagation delay nA to nY		14	25		31		38	ns	4.5	Fig. 6
$t_{PZH}/t_{PZL}$	3-state output enable time $\overline{OE}_n$ to nY		18	35		44		53	ns	4.5	Fig. 7
$t_{PHZ}/t_{PLZ}$	3-state output disable time $\overline{OE}_n$ to nY		23	35		44		53	ns	4.5	Fig. 7
$t_{THL}/t_{TLH}$	output transition time		5	12		15		18	ns	4.5	Fig. 6

AC WAVEFORMS

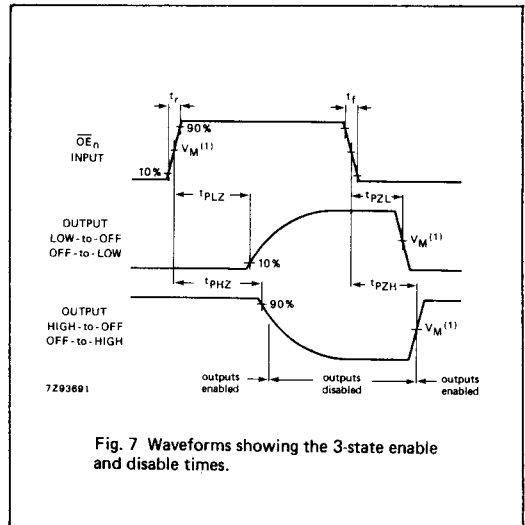
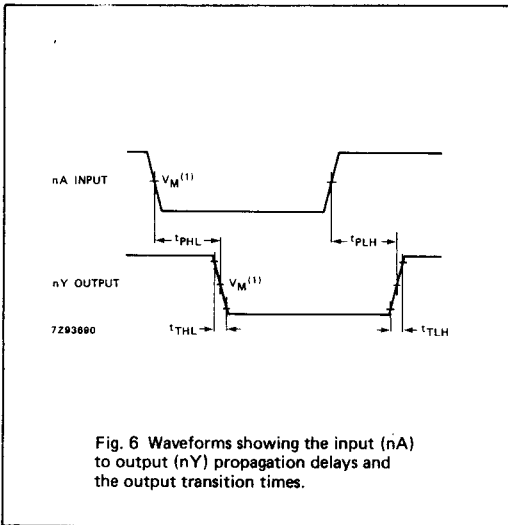

Note to AC waveforms

(1) HC :  $V_M = 50\%$ ;  $V_I = \text{GND to } V_{CC}$ .  
HCT:  $V_M = 1.3$  V;  $V_I = \text{GND to } 3$  V.