



P-Channel Enhancement Mode Field Effect Transistor

PRODUCT SUMMARY		
V _{DS}	I _D	R _{DS(ON)} (mΩ) Max
-18V	-5A	50 @ V _{GS} = -4.5V
		80 @ V _{GS} = -2.5V

FEATURES

- Super high dense cell design for low R_{DS(ON)}.
- Rugged and reliable.
- Surface Mount Package.

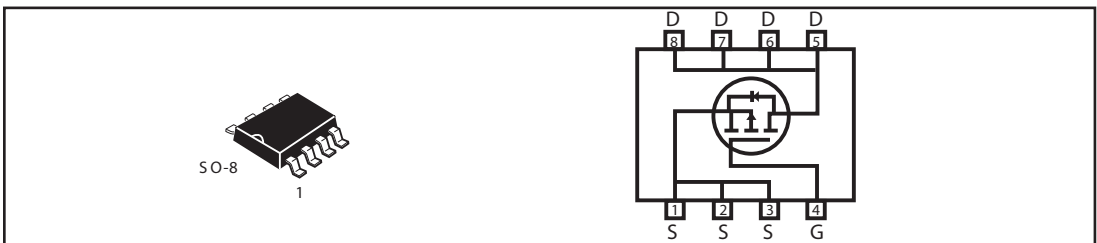

ABSOLUTE MAXIMUM RATINGS (T_A=25°C unless otherwise noted)

Parameter	Symbol	Limit	Unit
Drain-Source Voltage	V _{DS}	-18	V
Gate-Source Voltage	V _{GS}	±12	V
Drain Current-Continuous ^a @ T _J =125°C -Pulsed ^b	I _D	-5	A
	I _{DM}	-12.5	A
Drain-Source Diode Forward Current ^a	I _S	-1.7	A
Maximum Power Dissipation ^a	P _D	2.5	W
Operating Junction and Storage Temperature Range	T _J , T _{STG}	-55 to 150	°C

THERMAL CHARACTERISTICS

Thermal Resistance, Junction-to-Ambient ^a	R _{θJA}	50	°C/W
--	------------------	----	------

STM9433

ELECTRICAL CHARACTERISTICS (T_A = 25°C unless otherwise noted)

Parameter	Symbol	Condition	Min	Typ ^c	Max	Unit	
OFF CHARACTERISTICS							
Drain-Source Breakdown Voltage	BV _{DSS}	V _{GS} = 0V, I _D = -250μA	-18			V	
Zero Gate Voltage Drain Current	I _{DSS}	V _{DS} = -16V, V _{GS} = 0V			-1	μA	
Gate-Body Leakage	I _{GSS}	V _{GS} = ±12V, V _{DS} = 0V			±100	nA	
ON CHARACTERISTICS^b							
Gate Threshold Voltage	V _{GS(th)}	V _{DS} = V _{GS} , I _D = -250μA	-0.6	-0.96	-1.5	V	
Drain-Source On-State Resistance	R _{DS(ON)}	V _{GS} = -4.5V, I _D = -5.1A			50	m-ohm	
		V _{GS} = -2.5V, I _D = -2.0A			80	m-ohm	
On-State Drain Current	I _{D(ON)}	V _{DS} = -5V, V _{GS} = -4.5V	-8			A	
Forward Transconductance	g _{FS}	V _{DS} = -15V, I _D = -5.3A		6		S	
DYNAMIC CHARACTERISTICS^c							
Input Capacitance	C _{ISS}	V _{DS} = -10V, V _{GS} = 0V f = 1.0MHz		995		pF	
Output Capacitance	C _{OSS}			150		pF	
Reverse Transfer Capacitance	C _{RSS}			87		pF	
SWITCHING CHARACTERISTICS^c							
Turn-On Delay Time	t _{D(ON)}	V _D = -10V I _D = -1A V _{GEN} = -4.5V R _{GEN} = 6 ohm		6.1		ns	
Rise Time	t _r			14.8		ns	
Turn-Off Delay Time	t _{D(OFF)}				59		ns
Fall Time	t _f				29.6		ns
Total Gate Charge	Q _g	V _{DS} = -10V, I _D = -1A V _{GS} = -4.5V		9.6		nC	
Gate-Source Charge	Q _{gs}			1.2		nC	
Gate-Drain Charge	Q _{gd}			2.8		nC	

STM9433

ELECTRICAL CHARACTERISTICS ($T_A=25^{\circ}\text{C}$ unless otherwise noted)

Parameter	Symbol	Condition	Min	Typ ^c	Max	Unit
DRAIN-SOURCE DIODE CHARACTERISTICS^b						
Diode Forward Voltage	V_{SD}	$V_{GS} = 0V, I_s = -1.7A$		-0.82	-1.2	V

Notes

- a. Surface Mounted on FR4 Board, $t \leq 10\text{sec}$.
- b. Pulse Test: Pulse Width $\leq 300\mu\text{s}$, Duty Cycle $\leq 2\%$.
- c. Guaranteed by design, not subject to production testing.

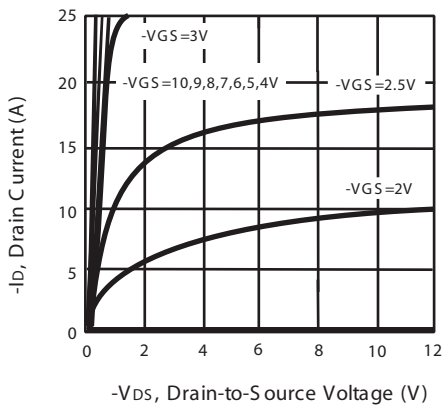

Figure 1. Output Characteristics

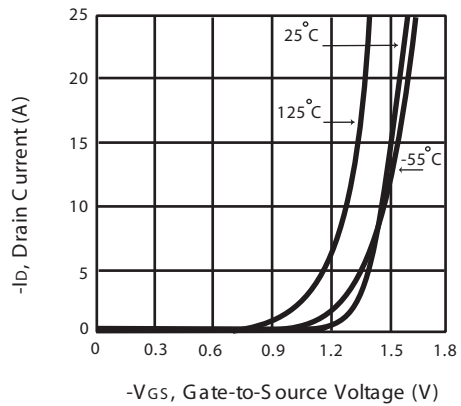

Figure 2. Transfer Characteristics

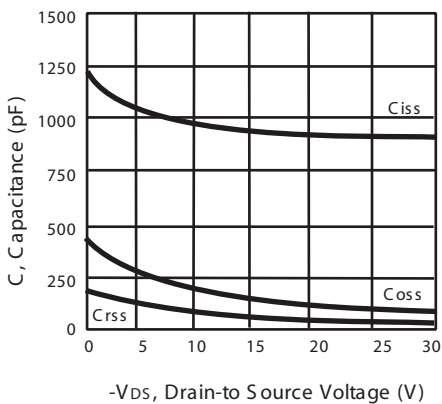

Figure 3. Capacitance

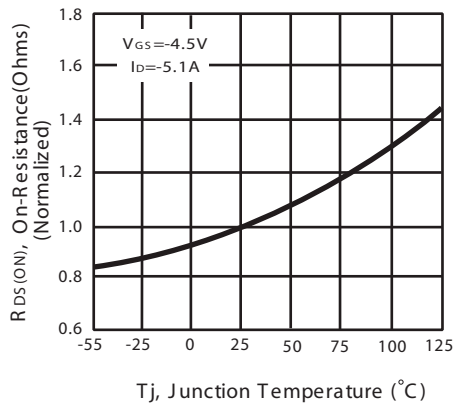

Figure 4. On-Resistance Variation with Temperature

STM9433

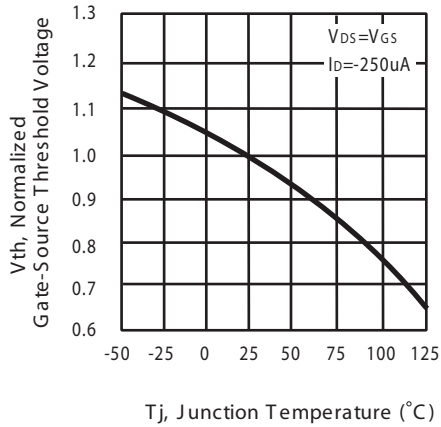

Figure 5. Gate Threshold Variation with Temperature

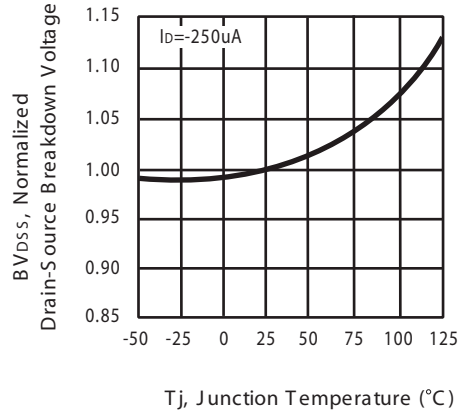

Figure 6. Breakdown Voltage Variation with Temperature

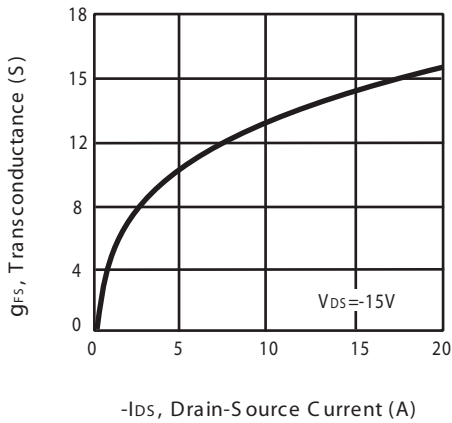

Figure 7. Transconductance Variation with Drain Current

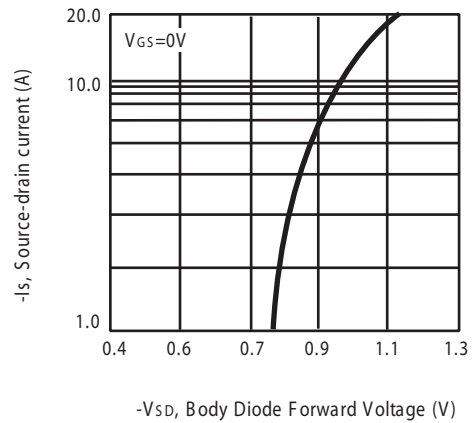

Figure 8. Body Diode Forward Voltage Variation with Source Current

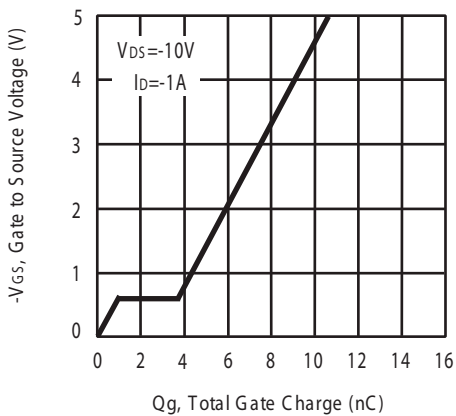

Figure 9. Gate Charge

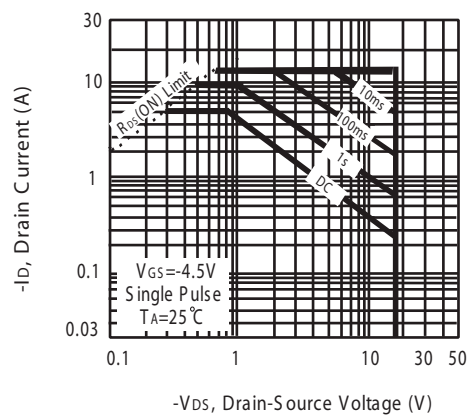

Figure 10. Maximum Safe Operating Area

STM9433

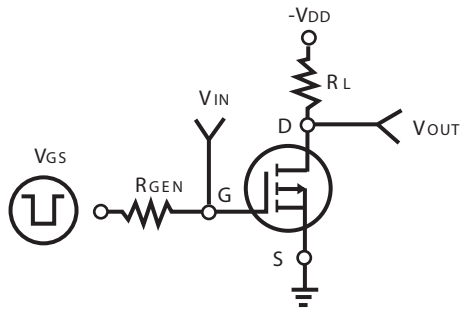

Figure 11. Switching Test Circuit

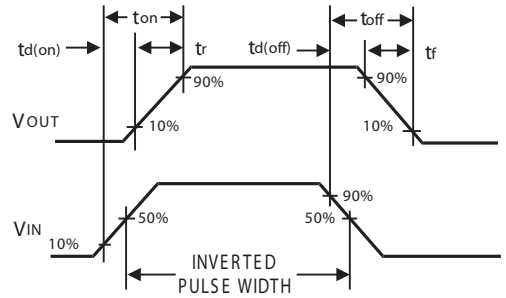

Figure 12. Switching Waveforms

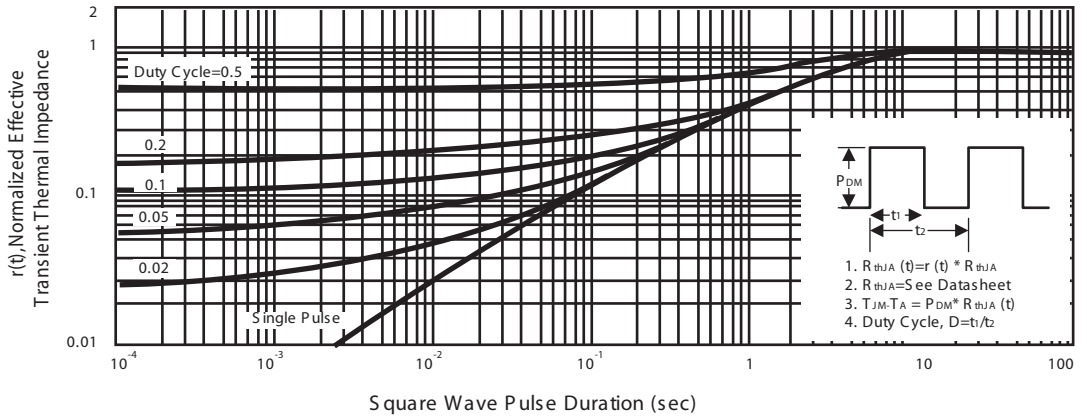
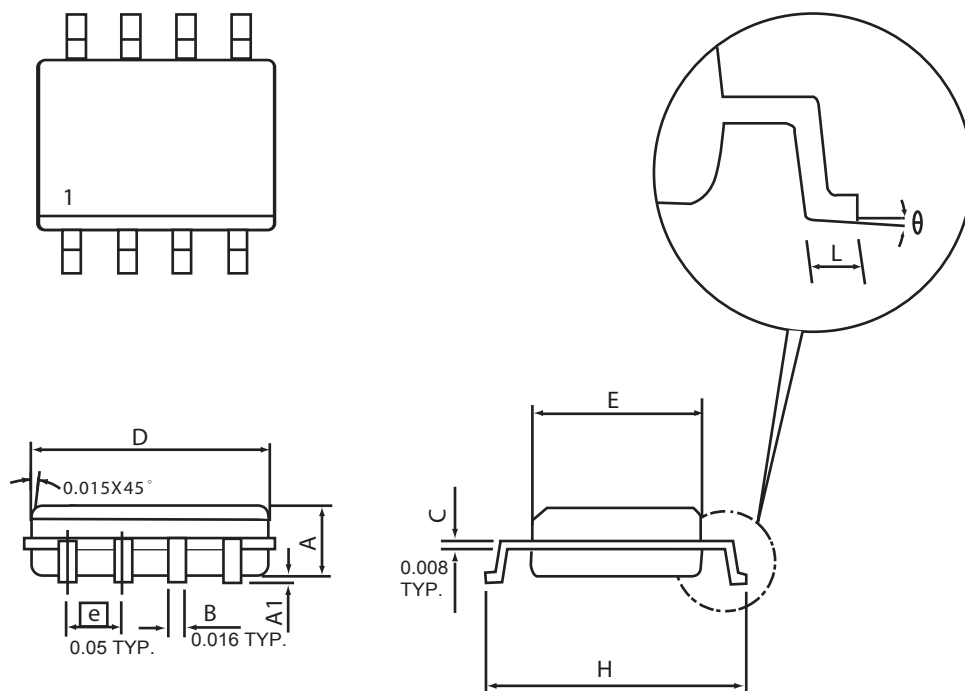

Figure 13. Normalized Thermal Transient Impedance Curve

STM9433

PACKAGE OUTLINE DIMENSIONS

SO-8



SYMBOLS	MILLIMETERS		INCHES	
	MIN	MAX	MIN	MAX
A	1.35	1.75	0.053	0.069
A1	0.10	0.25	0.004	0.010
D	4.80	4.98	0.189	0.196
E	3.81	3.99	0.150	0.157
H	5.79	6.20	0.228	0.244
L	0.41	1.27	0.016	0.050
θ	0°	8°	0°	8°

STM9433

SO-8 Tape and Reel Data

SO-8 Carrier Tape

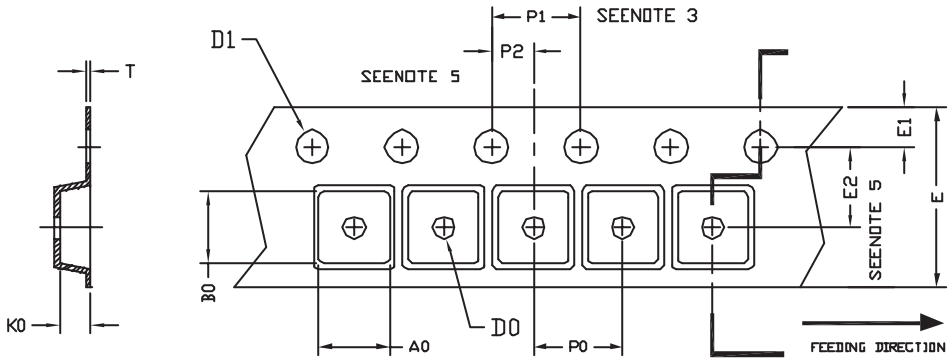

unit:mm

PACKAGE	A0	B0	K0	D0	D1	E	E1	E2	P0	P1	P2	T
SOP 8N 150mil	6.40	5.20	2.10	ϕ 1.5 (MIN)	ϕ 1.5 + 0.1 - 0.0	12.0 \pm 0.3	1.75	5.5 \pm 0.05	8.0	4.0	2.0 \pm 0.05	0.3 \pm 0.05

SO-8 Reel

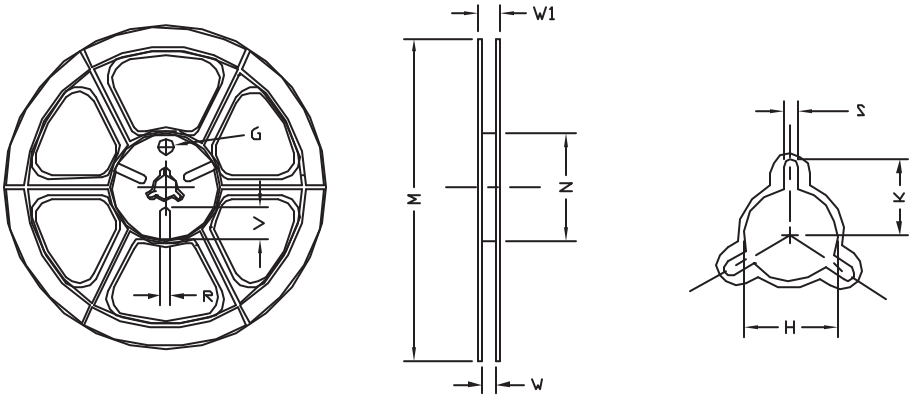

UNIT:mm

TAPE SIZE	REEL SIZE	M	N	W	W1	H	K	S	G	R	V
12 mm	ϕ 330	330 \pm 1	62 \pm 1.5	12.4 + 0.2	16.8 - 0.4	ϕ 12.75 + 0.15	---	2.0 \pm 0.15	---	---	---