



SANYO Semiconductors

DATA SHEET

LA4917H

Monolithic Linear IC

Audio Output for TV application

High-Efficiency Two-Channel 7W BTL Power Amplifier ICs

Overview

The LA4917H is a high-efficiency two-channel 7W BTL power amplifier IC. Increases in the number of external components are held to a minimum by adopting both a signal-following type switching scheme in the amplifier's output stage power supply, and a nonlinear amplifier that has nonlinear characteristics in the signal system. The power dissipation (thermal loss) in the actual operating range has been reduced to about 1/2 that of earlier class B amplifier ICs.

When used with the DIP-28H package, the IC dispenses with the heat sink and significantly contributes to space saving in the end product case.

Features

- High-efficiency two-channel 7W BTL power amplifier IC ($V_{CC} = 12V$, $R_L = 8\Omega$)
- Encapsulated in a DIP-28H package (heat sink free)
- Requires only one signal-following type switching circuit, contributing to a reduction in the number of external components
- Provides analog outputs that generate no switching noise on the output lines
- Built-in standby switches
- Built-in protection circuits (overvoltage and thermal protection circuits)

Specifications

Maximum Ratings at $T_a = 25^\circ C$

Parameter	Symbol	Conditions	Ratings	Unit
Maximum supply voltage	$V_{CC\ max}$	No signal	24	V
Allowable power dissipation	$P_d\ max$	Our recommendation substrate	6.2	W
Maximum junction temperature	$T_j\ max$		150	$^\circ C$
Operating temperature	T_{opr}		-25 to +75	$^\circ C$
Storage temperature	T_{stg}		-40 to +150	$^\circ C$

Operating Conditions at $T_a = 25^\circ C$

Parameter	Symbol	Conditions	Ratings	Unit
Recommended supply voltage	V_{CC}		12	V
Recommended load resistance	R_L		8	Ω
Operating supply voltage range	$V_{CC\ op}$		8 to 16	V

■ Any and all SANYO Semiconductor products described or contained herein do not have specifications that can handle applications that require extremely high levels of reliability, such as life-support systems, aircraft's control systems, or other applications whose failure can be reasonably expected to result in serious physical and/or material damage. Consult with your SANYO Semiconductor representative nearest you before using any SANYO Semiconductor products described or contained herein in such applications.

■ SANYO Semiconductor assumes no responsibility for equipment failures that result from using products at values that exceed, even momentarily, rated values (such as maximum ratings, operating condition ranges, or other parameters) listed in products specifications of any and all SANYO Semiconductor products described or contained herein.

SANYO Semiconductor Co., Ltd.

TOKYO OFFICE Tokyo Bldg., 1-10, 1 Chome, Ueno, Taito-ku, TOKYO, 110-8534 JAPAN

LA4917H

Electrical Characteristics at $T_a = 25^\circ\text{C}$, V_{CC} (Pin 21), Pre V_{CC} (Pin 20) = 12V, $R_L = 8\Omega$, $f = 1\text{kHz}$, $R_g = 600\Omega$,
See the specified board and circuit.

Parameter	Symbol	Conditions	Ratings			Unit
			min	typ	max	
Quiescent current	I_{CCO}	$R_g = 0, R_L = \text{Open}$	35	60	120	mA
Standby current	I_{st}	Amplifier off		0	10	μA
Voltage gain	VG	$V_O = 0\text{dBm}$	27.2	29.2	31.2	dB
Output power	P_O	THD = 10%	5	7		W
Total harmonic distortion	THD	$P_O = 1\text{W}$, LPF = 30kHz		0.09	0.4	%
Output noise voltage	V_{NO}	$R_g = 0$, DIN AUDIO*		0.05	0.3	mVrms
Ripple rejection	SVRR	$R_g = 0$, $f_R = 100\text{Hz}$, $V_R = 0\text{dBm}$, DIN AUDIO*	60	75		dB
Channel separation	CHsep	$R_g = 10\text{k}\Omega$, $V_O = 0\text{dBm}$, DIN AUDIO*	50	60		dB
Input resistance	R_i		21	30	39	$\text{k}\Omega$
Output offset voltage	V_N offset	$R_g = 0$	-120		+120	mV
Standby OFF voltage	V_{ST}	Amplifier on	2.5		16	V
		Amplifier off	0		1.0	V

* : A DIN audio filter (20Hz to 20kHz) is used during measurement.

Package Dimensions

unit : mm (typ)

3233B

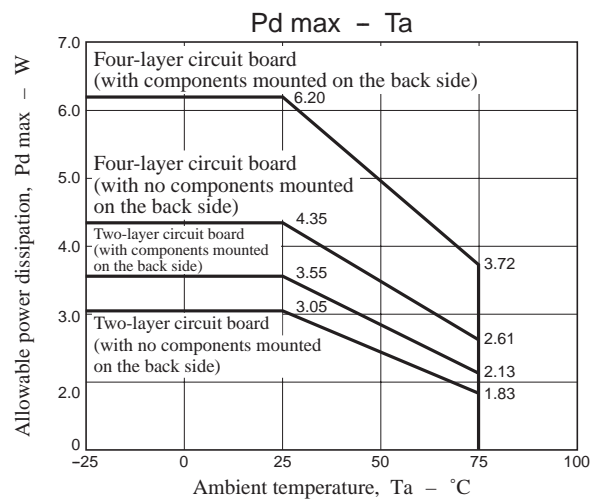
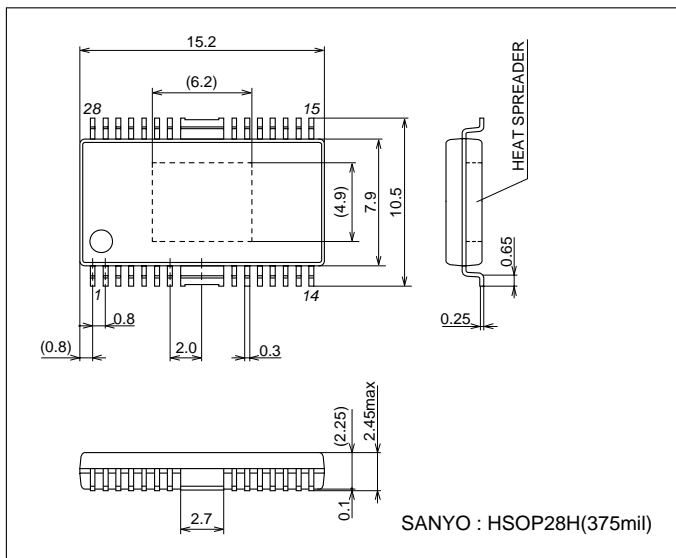

LA4917H

Block Diagram

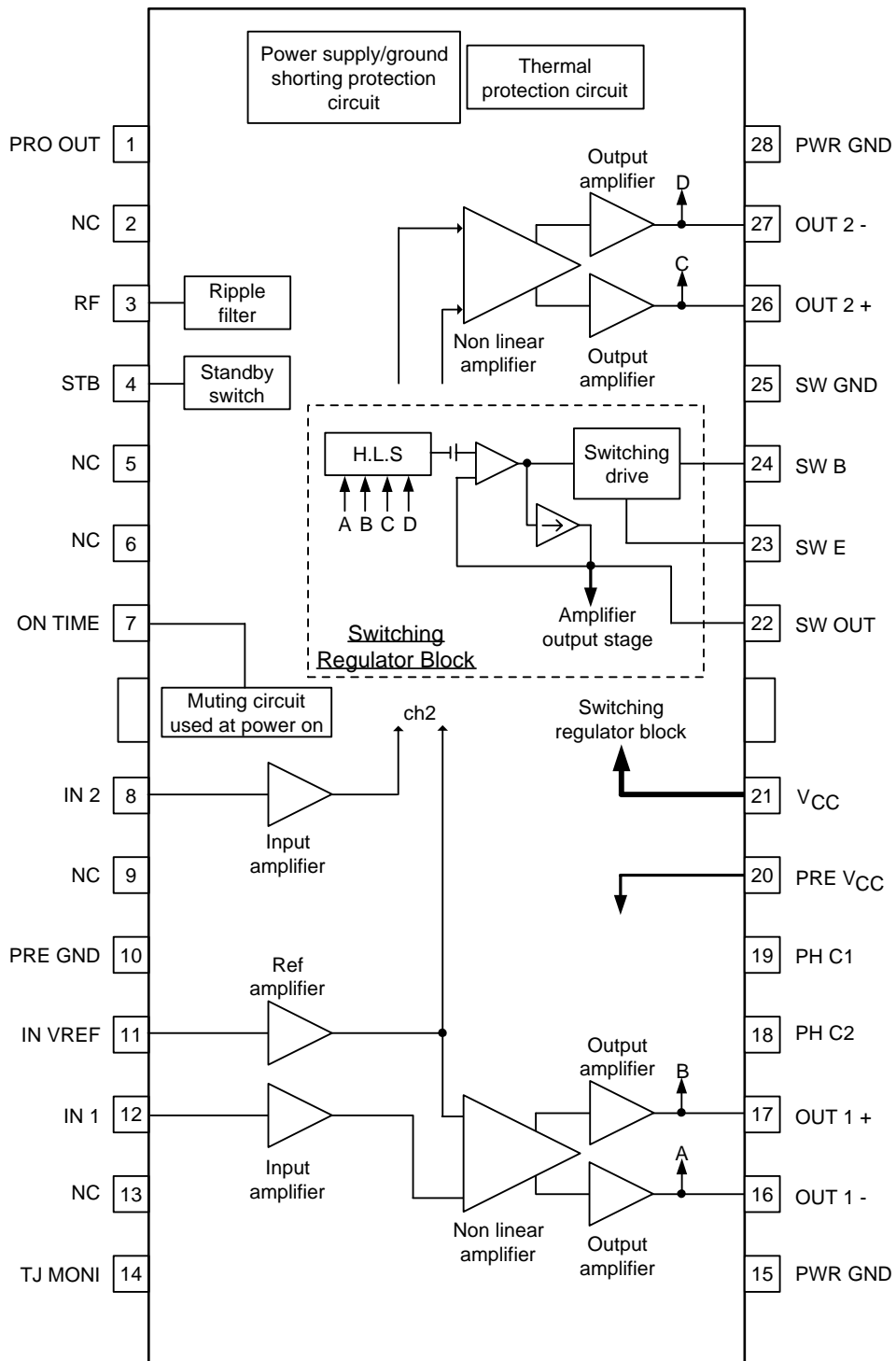

LA4917H

Measurement Circuit

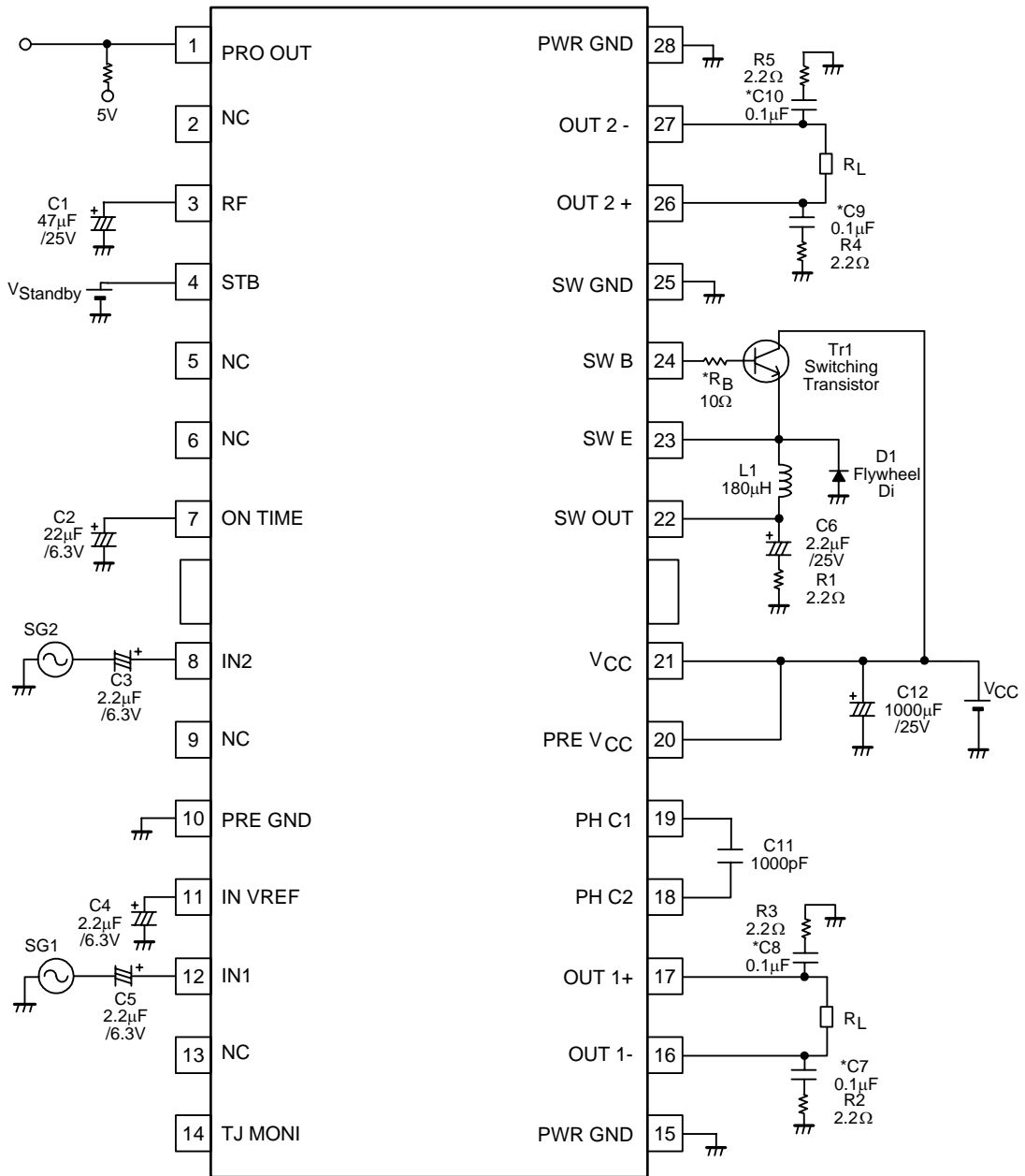

External Component Descriptions

- C1 : This capacitor functions as a ripple filter. A value of $47\mu\text{F}$ is recommended.
- C2 : This capacitor sets the amplifier startup wait time. A value of $22\mu\text{F}$ is recommended. (With this value, the startup wait time will be about 0.7 seconds.) Although the startup wait time can be made shorter by reducing the value of this capacitor, this can result in impulse noise appearing in the output. We recommend always using a value larger than $10\mu\text{F}$.
- C3 and C5 : Input capacitors. A value of $22\mu\text{F}$ is recommended. Note that if made variable, a value of $3.3\mu\text{F}$ or lower should be used due to impulse noise considerations.
- C4 : This capacitor is the input reference amplifier capacitor, and the value must be the same as that of C3 and C5.
- C6 and R1 : Smoothing capacitor for the switching regulator output. The LA4917H adopts a self-excited oscillation switching regulator design. Since this capacitor influences the stability of the self-excited oscillation, we recommend keeping the equivalent series resistance at high frequencies low (roughly 3Ω or lower) and using a capacitor with good thermal characteristics. For similar reasons, a value of 2.2Ω should be used for R1.
- C7, C8, C9, and C10 : Oscillation prevention capacitors. We recommend using polyester film capacitors (Mylar capacitor) with good thermal characteristics for these capacitors. These are used together with R2, R3, R4, and R5.
- C11 : Switching regulator oscillation prevention capacitor. We recommend a value of 1000pF .
- C12 : Power supply capacitor
- Tr1 and *R_B : This is an external switching transistor. Since the collector current has a peak of about 1.5A, we recommend using a transistor in the $f_T = 30$ to 50MHz range according to the current capacity required. Note that if a transistor with an f_T of 100MHz or higher is used, oscillation may be induced in the switching waveform. Therefore in this case a base resistor, *R_B, with a resistance of about 10Ω must be added and the circuit adjusted so that oscillation does not occur.
- L1 : We recommend a coil inductance in the range 150 to $220\mu\text{H}$.
- D1 : This is a flywheel diode that absorbs the coil energy. We recommend the use of a Schottky barrier diode with a low VF.

Notes on the Switching Regulator (Pins 22 to 24)

- The LA4917H includes a signal-following self-excitation switching regulator to hold power consumption to a minimum. The self-excitation oscillation frequency when no signal is input will be in the range from about 130 to 170kHz .
- Transistor Tr1 is an external switching transistor. We recommend using a device with $I_C = 2.5\text{A}$ and $f_T = 30$ to 50MHz . If a transistor with an f_T of 100MHz or higher is used, oscillation may be induced in the switching waveform. Therefore in this case a base resistor (R_B, about 10Ω) must be added and the circuit adjusted so that oscillation does not occur.
- C6 is used to smooth the output of the switching regulator. Since this capacitor influences the stability of the self-excited oscillation, we recommend keeping the equivalent series resistance at high frequencies low and using a capacitor with good thermal characteristics. The recommended value for this capacitor is $2.2\mu\text{F}$. Note that for similar reasons, a resistor with a value of 2.2Ω should be used for R1.
- D1 is a flywheel diode that absorbs the coil energy. We recommend the use of a Schottky barrier diode with a low VF.

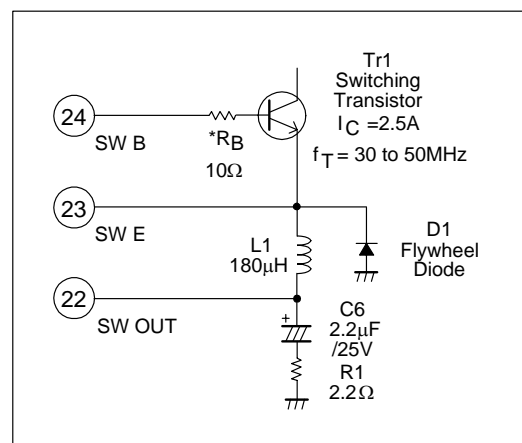

Notes on the Standby Function (STB, pin 4)

The amplifier is turned on by applying a level of 2.5V (minimum) or higher to pin 4.

Pin 4 control voltage

Voltage applied to pin 4 (V)	Amplifier	Standby
0 to 1.0	Off	On
2.5 to 16	On	Off

The limit resistor R_{STB} may be inserted if the V_{ST} applied voltage is comparatively high and there is a need to suppress the pin 4 sink current.

Example : When it is necessary to limit the pin 4 sink current to under $500\mu A$.

$$R_{STB} = \frac{V_{ST} - 2V_{BE} \text{ (about 1.4V)}}{500\mu A} - 10k\Omega$$

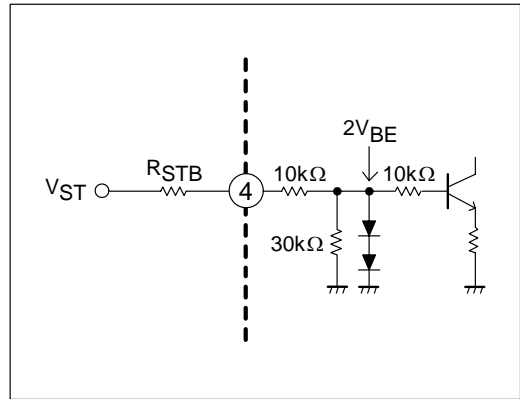

Notes on the Self Diagnostics Function (PRO OUT, pin 1)

The self diagnostics function detects when a power amplifier output pin has been shorted to V_{CC} or ground and reports that state to external circuits.

In the example shown at the right, during normal operation this output will be at the high level, but if the protection circuit operates, an internal transistor will be turned on and the pin will go to the low level (about 0.2 to 0.3V).

Note that this circuit has an npn transistor open-collector output.

* : This pin is left open when this function is not used.

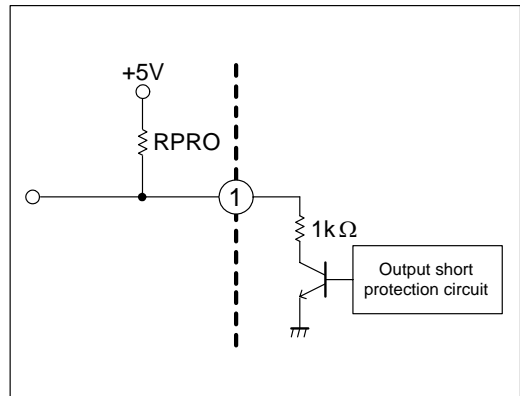

Notes on the TJ MONI Function (pin 14)

The pin 14 internal circuit has diodes (three diodes connected in series) connected to ground as shown in the circuit diagram figure. These diodes' forward voltage has the temperature dependence shown in the figure at the lower left. The IC's internal junction temperature can be inferred using these characteristics.

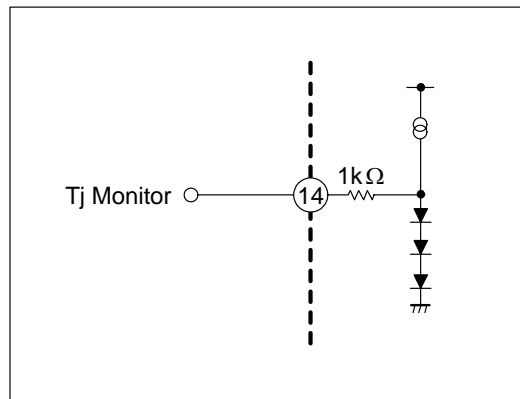
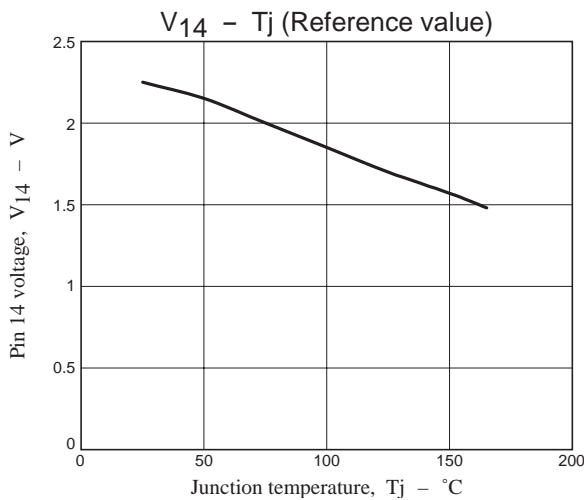

Circuit Board Specifications (LA4917H recommended circuit boards)

1) Four-layer circuit board (2S2P)

Board size : 90×90×1.6mm (glass epoxy)

Copper wiring densities : L1 = 60%, L2 = 90%, L3 = 90%, and L4 = 90% (LA4917H mounting surface)

2) Two-layer board (2SOP)

Board size : 90×90×1.6mm (glass epoxy)

Copper wiring densities : L1 = 60% and L2 = 90% (LA4917H mounting surface)

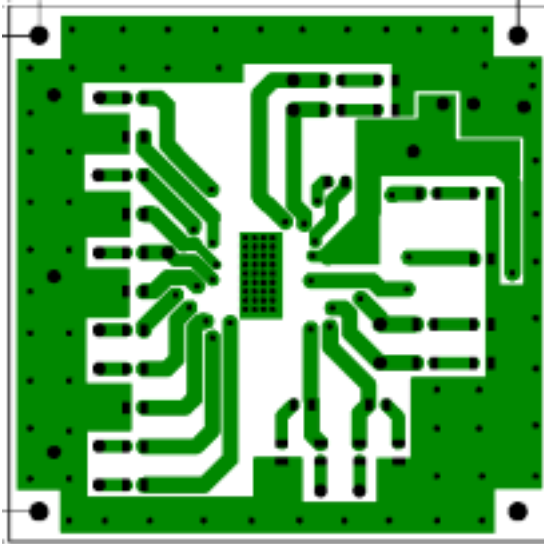

L1 : Copper wiring pattern diagram

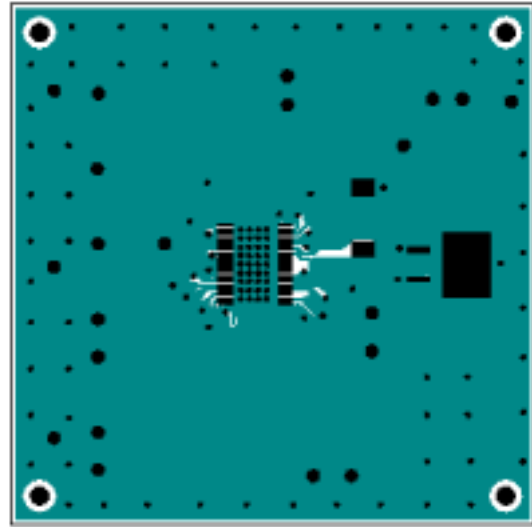

L4 (four-layer circuit board),
L2 (two-layer circuit board) :
Copper wiring pattern diagram

Notes

1. The data for the back surface solder mounting case applies when 80% or more of the heat sink surface is wetted.
2. End products must be designed with enough derating to provide adequate margins.
The stresses for which derating must be applied are as follows : voltage, current, junction temperature, power loss and mechanical stresses such as vibration and shock. Therefore end products must also be designed to keep these stresses as low or as small as possible.
We present some common derating standards below.
 - (1) For voltage ratings, 80% or less of the maximum value
 - (2) For current ratings, 80% or less of the maximum value
 - (3) For temperature ratings, 80% or less of the maximum value
3. In product design, full testing must be performed in an actual end product.
Furthermore, not only must the solder joint states of heat sinks and heat dissipation fins be checked carefully, but thorough reliability testing of all solder joints must also be performed. If voids or degradation of the solder joints in these areas are found, the thermal conductivity with the circuit board will be degraded and this can lead to thermal destruction of the IC. In such cases, reanalyze the usage conditions, look into optimizing circuit board land dimensions, masks, and printing conditions, and use a solder with superlative thermal stress resistance.

Usage Notes

1. This IC includes power supply shorting (shorting between the power supply and the outputs) and ground shorting (shorting between ground and the outputs) protection circuits. These circuits operate to protect the IC against abnormal connections.
These circuits will continue to operate as long as the corresponding abnormal condition continues and recover automatically when the abnormal condition is cleared.
2. This IC includes a thermal protection circuit that operates when the junction temperature (T_j) exceeds about 160°C. This circuit gradually lowers (attenuates) the outputs.
3. If this IC is operated in the vicinity of its maximum ratings, small fluctuations in the operating conditions may cause the maximum ratings to be exceeded and may lead to destruction of the IC. Therefore, designs must provide adequate margins in the supply voltage and other parameters so that this IC will only be used within ranges such that the maximum ratings are never exceeded.

- Specifications of any and all SANYO Semiconductor products described or contained herein stipulate the performance, characteristics, and functions of the described products in the independent state, and are not guarantees of the performance, characteristics, and functions of the described products as mounted in the customer's products or equipment. To verify symptoms and states that cannot be evaluated in an independent device, the customer should always evaluate and test devices mounted in the customer's products or equipment.
- SANYO Semiconductor Co., Ltd. strives to supply high-quality high-reliability products. However, any and all semiconductor products fail with some probability. It is possible that these probabilistic failures could give rise to accidents or events that could endanger human lives, that could give rise to smoke or fire, or that could cause damage to other property. When designing equipment, adopt safety measures so that these kinds of accidents or events cannot occur. Such measures include but are not limited to protective circuits and error prevention circuits for safe design, redundant design, and structural design.
- In the event that any or all SANYO Semiconductor products (including technical data, services) described or contained herein are controlled under any of applicable local export control laws and regulations, such products must not be exported without obtaining the export license from the authorities concerned in accordance with the above law.
- No part of this publication may be reproduced or transmitted in any form or by any means, electronic or mechanical, including photocopying and recording, or any information storage or retrieval system, or otherwise, without the prior written permission of SANYO Semiconductor Co., Ltd.
- Any and all information described or contained herein are subject to change without notice due to product/technology improvement, etc. When designing equipment, refer to the "Delivery Specification" for the SANYO Semiconductor product that you intend to use.
- Information (including circuit diagrams and circuit parameters) herein is for example only; it is not guaranteed for volume production. SANYO Semiconductor believes information herein is accurate and reliable, but no guarantees are made or implied regarding its use or any infringements of intellectual property rights or other rights of third parties.

This catalog provides information as of November, 2006. Specifications and information herein are subject to change without notice.