



ECG015

1/4 Watt, High Linearity InGaP HBT Amplifier

The Communications Edge™

Product Information

Product Features

- 1800 – 2500 MHz
- +24 dBm P1dB
- +41 dBm OIP3
- 15 dB Gain
- 5 dB Noise Figure
- Single Positive Supply (+8V)
- Lead-free/Green/RoHS - compliant SOT-89 Package

Applications

- Mobile Infrastructure
- W-LAN / ISM
- RFID
- Defense / Homeland Security
- Fixed Wireless

Product Description

The ECG015 is a high dynamic range driver amplifier in a low-cost surface mount package. The InGaP/GaAs HBT is able to achieve performance over a broad range with +41 dBm OIP3 and +24 dBm of compressed 1dB power and is housed in a lead-free/green/RoHS-compliant SOT-89 SMT package. All devices are 100% RF and DC tested.

The product is targeted for use as a gain block/driver amplifier for various current and next generation wireless technologies such as CDMA, DCS1800 and CDMA2000, where high linearity and medium power is required. In addition, the ECG015 will work for numerous other applications within the 1800 to 2500 MHz frequency range.

Functional Diagram

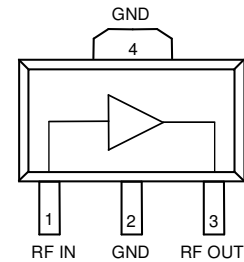

Pin No.	Function
1	Input
3	Output/Bias
2, 4	Ground

Specifications ⁽¹⁾

Parameter	Units	Min	Typ	Max
Operational Bandwidth	MHz	1800		2500
Test Frequency	MHz		2140	
Gain	dB	13.5	15	
Input Return Loss	dB		20	
Output Return Loss	dB		10	
Output P1dB	dBm	+22	+24	
Output IP3 ⁽²⁾	dBm	+37.5	+41	
Noise Figure	dB		5	
Device Voltage	V		5	
Device Current	mA	85	100	135

1. Test conditions unless otherwise noted: 25°C, V_{supply} = +8 V, in tuned application circuit with R_{bias} = 30 Ω.
2. 3OIP measured with two tones at an output power of +9 dBm/tone separated by 1 MHz. The suppression on the largest IM3 product is used to calculate the 3OIP using a 2:1 rule.

Typical Performance ⁽³⁾

Parameter	Units	Typical		
Frequency	MHz	1900	2140	2450
S21	dB	16.5	15	14.5
S11	dB	-9	-20	-12
S22	dB	-9.5	-10	-9
Output P1dB	dBm	+24	+24	+23
Output IP3 ⁽²⁾	dBm	+41	+41	+42
Noise Figure	dB	5	5	5

3. Typical parameters reflect performance in a tuned application circuit: Supply Voltage = +8 V, I_{cc} = 100 mA, +25 °C, R_{bias} = 30 Ω.

Absolute Maximum Rating

Parameter	Rating
Operating Case Temperature	-40 to +85 °C
Storage Temperature	-55 to +150 °C
Device Current	180 mA
RF Input Power (continuous)	+15 dBm
Junction Temperature	+250 °C

Operation of this device above any of these parameters may cause permanent damage.

Ordering Information

Part No.	Description
ECG015B-G	0.2 Watt, High Linearity InGaP HBT Amplifier (lead-free/green/RoHS-compliant SOT-89 package)
ECG015B-PCB1960	1960 MHz Fully Assembled Eval. Board
ECG015B-PCB2140	2140 MHz Fully Assembled Eval. Board

Specifications and information are subject to change without notice



Typical Device Data

S-parameters ($V_{device} = +5V$, $I_{cc} = 100\text{ mA}$, $25\text{ }^\circ\text{C}$, unmatched 50 ohm system)

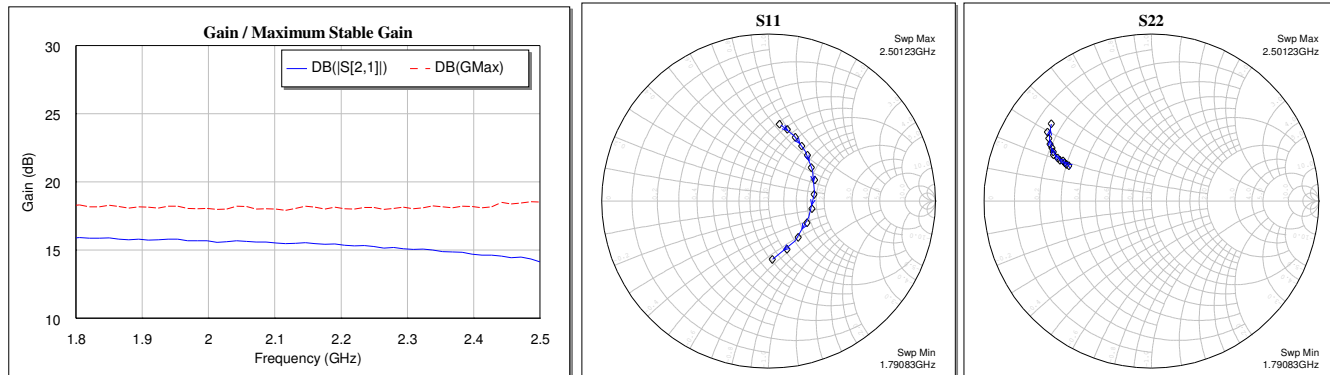

Notes:

The gain for the unmatched device in 50 ohm system is shown as the trace in blue color. For a tuned circuit for a particular frequency, it is expected that actual gain will be higher, up to the maximum stable gain. The maximum stable gain is shown in the dashed red line.

The impedance plots are shown from 1800 – 2500 MHz, with markers placed at 1.8 – 2.5 GHz in 0.05 GHz increments.

S-Parameters ($V_{device} = +5\text{ V}$, $I_{cc} = 100\text{ mA}$, $T = 25\text{ }^\circ\text{C}$, unmatched 50 ohm system, calibrated to device leads)

Freq (MHz)	S11 (dB)	S11 (ang)	S21 (dB)	S21 (ang)	S12 (dB)	S12 (ang)	S22 (dB)	S22 (ang)
1800	-6.70	80.76	15.90	24.47	-28.55	-25.74	-5.34	156.39
1900	-7.55	68.30	15.77	16.51	-28.96	-32.29	-4.96	156.21
2000	-8.60	53.47	15.66	7.76	-30.14	-38.84	-4.56	155.58
2100	-9.85	35.06	15.53	-1.19	-31.49	-45.79	-4.12	155.07
2200	-11.07	10.07	15.40	-10.90	-33.04	-59.63	-3.67	153.49
2300	-11.69	-21.71	15.08	-20.90	-36.28	-78.21	-3.20	150.85
2400	-10.87	-56.13	14.67	-31.83	-40.69	-106.46	-2.80	147.22
2500	-9.15	-86.03	14.14	-43.53	-42.21	163.73	-2.44	142.35

Device S-parameters are available for download off of the website at: <http://www.wj.com>

Application Circuit PC Board Layout

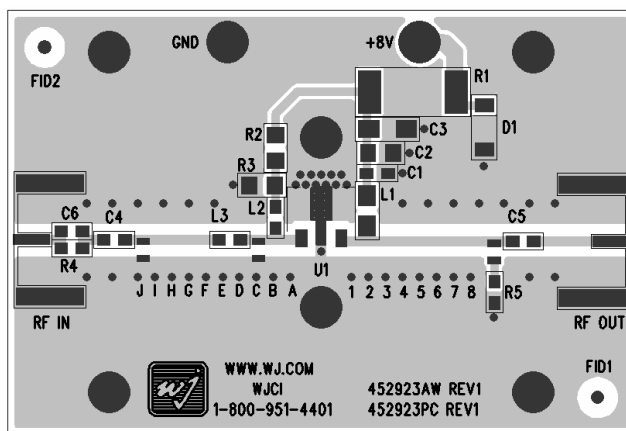

Circuit Board Material: .014" Getek, 4 - layer, 1 oz copper, Microstrip line details: width = .026", spacing = .026"
The silk screen markers 'A', 'B', 'C', etc. and '1', '2', '3', etc. are used as placemarkers for the input and output tuning shunt capacitors. The markers and vias are spaced in .050" increments.



1960 MHz Application Circuit (ECG015B-PCB1960)

Typical RF Performance at 25 °C

Frequency	1960 MHz
Gain	16.5 dB
Input Return Loss	9 dB
Output Return Loss	9.5 dB
Output P1dB	+24 dBm
Output IP3* (+9 dBm / tone, 1 MHz spacing)	+41 dBm
Channel Power (@-45 dBc ACPR, IS-95 9 channels fwd)	+17 dBm
Noise Figure	5 dB
Device Voltage	+5 V
Quiescent Current	100 mA

* Please see note 2 on page 1.

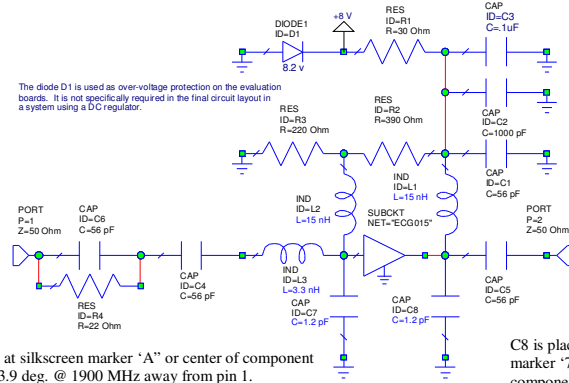

C7 placed at silkscreen marker 'A' or center of component placed at 3.9 deg. @ 1900 MHz away from pin 1.

C8 is placed at silkscreen marker '7' or center of component placed at 32 deg. @ 1.9 GHz away from pin 3.

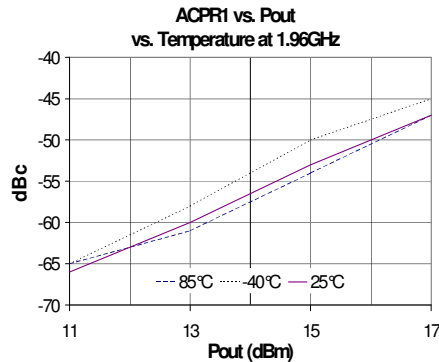
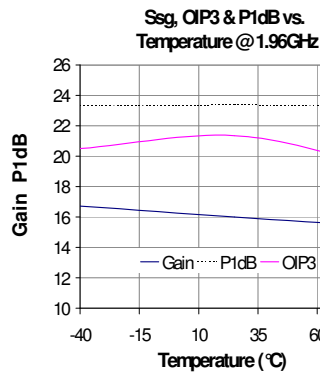

2140 MHz Application Circuit (ECG015B-PCB2140)

Typical RF Performance at 25 °C

Frequency	2140 MHz
Gain	15 dB
Input Return Loss	20 dB
Output Return Loss	10 dB
Output P1dB	+24 dBm
Output IP3* (+9 dBm / tone, 1 MHz spacing)	+41 dBm
Noise Figure	5 dB
Device Voltage	+5 V
Quiescent Current	100 mA

* Please see note 2 on page 1.

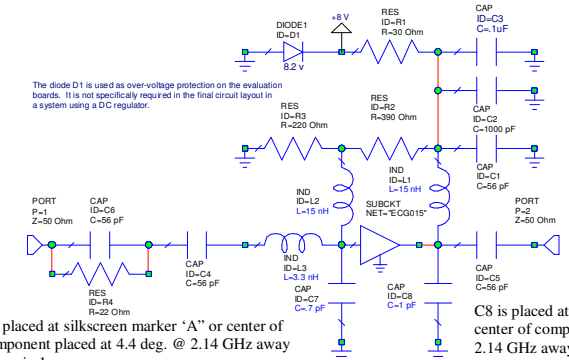

C7 placed at silkscreen marker 'A' or center of component placed at 4.4 deg. @ 2.14 GHz away from pin 1.

C8 is placed at silkscreen marker '7' or center of component placed at 37 deg. @ 2.14 GHz away from pin 3.

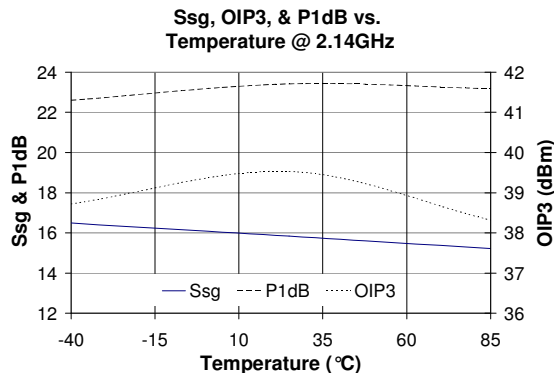

Specifications and information are subject to change without notice



2450 MHz Reference Design

Typical RF Performance at 25 °C

Frequency	2450 MHz
Gain	14.5 dB
Input Return Loss	12 dB
Output Return Loss	9 dB
Output P1dB	+23 dBm
Output IP3* (+9 dBm / tone, 1 MHz spacing)	+42 dBm
Noise Figure	5 dB
Device Voltage	+5 V
Quiescent Current	100 mA

* Please see note 2 on page 1.

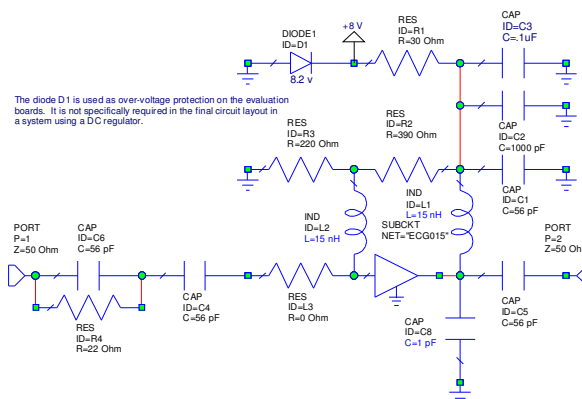

C8 placed half way between silkscreen marker '3' and '4' or center of component placed at 23 deg. @ 2.45 GHz away from pin 3.

Ssg, OIP3 and P1dB vs. Temperature at 2.45GHz

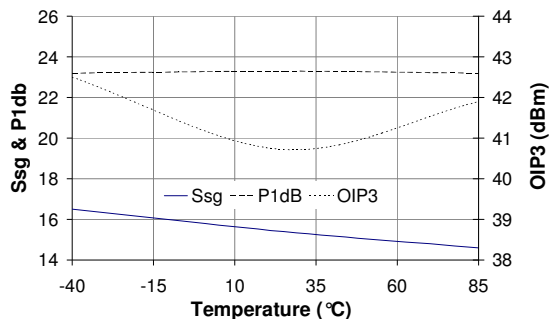



ECG015B Mechanical Information

This package is lead-free/Green/RoHS-compliant. It is compatible with both lead-free (maximum 260 °C reflow temperature) and leaded (maximum 245 °C reflow temperature) soldering processes. The plating material on the leads is NiPdAu.

Outline Drawing

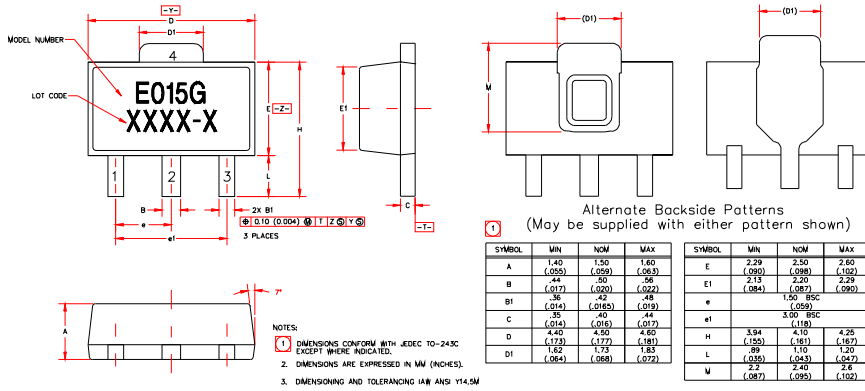

Land Pattern

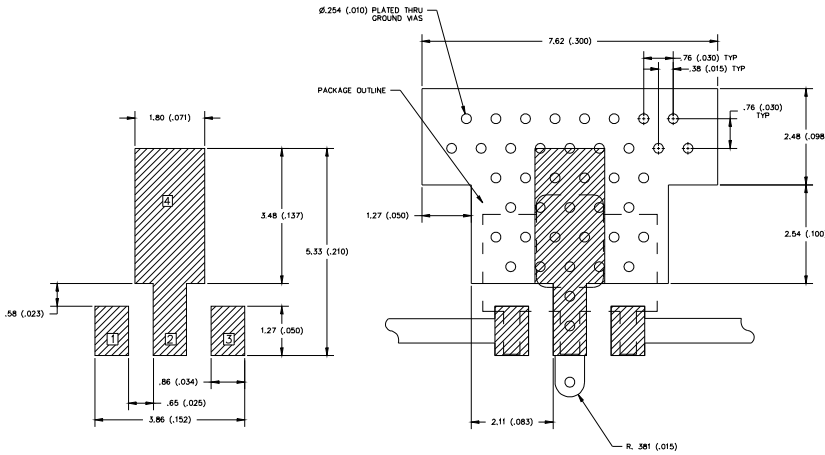

Thermal Specifications

Parameter	Rating
Operating Case Temperature	-40 to +85 °C
Thermal Resistance, Rth ⁽¹⁾	128 °C / W
Junction Temperature, Tj ⁽²⁾	149 °C

Notes:

- The thermal resistance is referenced from the junction-to-case at a case temperature of 85 °C. Tj is a function of the voltage and the current applied to pin 3 and can be calculated by:
 $T_j = T_{case} + R_{th} * I_{dc} * V_{de}$
- This corresponds to the typical biasing condition of +5V, 100 mA at an 85° C case temperature. A minimum MTTF of 1 million hours is achieved for junction temperatures below 247 °C.

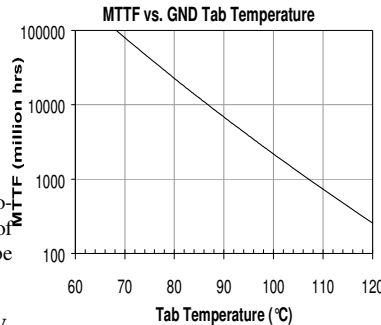

Product Marking

The component will be marked with an "E015G" designator with an alphanumeric lot code on the top surface of the package. The obsolete tin-lead package is marked with an "E015" designator followed by an alphanumeric lot code.

Tape and reel specifications for this part are located on the website in the "Application Notes" section.

ESD / MSL Information



Caution! ESD sensitive device.

ESD Rating: Class 1B
 Value: Passes at between 500 and 1000V
 Test: Human Body Model (HBM)
 Standard: JEDEC Standard JESD22-A114

MSL Rating: Level 3 at +260 °C convection reflow
 Standard: JEDEC Standard J-STD-020

Mounting Config. Notes

- Ground / thermal vias are critical for the proper performance of this device. Vias should use a .35mm (#80 / .0135") diameter drill and have a final plated thru diameter of .25 mm (.010").
- Add as much copper as possible to inner and outer layers near the part to ensure optimal thermal performance.
- Mounting screws can be added near the part to fasten the board to a heatsink. Ensure that the ground / thermal via region contacts the heatsink.
- Do not put solder mask on the backside of the PC board in the region where the board contacts the heatsink.
- RF trace width depends upon the PC board material and construction.
- Use 1 oz. Copper minimum.
- All dimensions are in millimeters (inches). Angles are in degrees.