

RF2638

Absolute Maximum Ratings

Parameter	Rating	Unit
Supply Voltage	-0.5 to +5.0	V _{DC}
Input RF Power	+3	dBm
Operating Ambient Temperature	-30 to +80	°C
Storage Temperature	-30 to +150	°C



Caution! ESD sensitive device.

RF Micro Devices believes the furnished information is correct and accurate at the time of this printing. RoHS marking based on EU Directive 2002/95/EC (at time of this printing). However, RF Micro Devices reserves the right to make changes to its products without notice. RF Micro Devices does not assume responsibility for the use of the described product(s).

Parameter	Specification			Unit	Condition
	Min.	Typ.	Max.		
Overall					T=25°C, V _{CC} =3.0V
RF Output Frequency Range		500 to 2500		MHz	
Spurious Product Rejection		30		dBc	Referenced to RF output
Cellular					T=25°C, V _{CC} =3.0V, LO=960MHz @ -3dBm, IF=130MHz @ -13dBm
Conversion Gain	-1	-0.5		dB	RF _{OUT} =830MHz
Noise Figure	-2.2	-1		dB	RF _{OUT} =836MHz (Dual-Output board)
Output IP3		14		dB	RF _{OUT} =830MHz
		+13		dBm	P _{IN} =-13dBm per Tone, RF out=830MHz
PCS					T=25°C, V _{CC} =3.0V, LO=1750MHz @ -3dBm, IF=130MHz @ -13dBm
Conversion Gain	-3.0	-1.5		dB	RF _{OUT} =1880MHz
Noise Figure	-3.5	-2.5		dB	RF _{OUT} =1880MHz (Dual-Output board)
Output IP3	+7	+11		dBm	RF _{OUT} =1880MHz
					P _{IN} =-13dBm per Tone, RF out=1880MHz
W-CDMA					T=25°C, V _{CC} =3.0V, LO=2330MHz @ -3dBm, IF=380MHz @ -13dBm
ACPR	-58	-57	-56	dBc	
Conversion Gain	-2.0	-1.0	0	dB	RF _{OUT} =1950MHz
Noise Figure	13	14	15	dB	RF _{OUT} =1950MHz
Output IP3	+8	+10		dBm	P _{IN} =-13dBm per Tone, RF _{OUT} =1950MHz
Max OIP3			11	dBm	
IF Input					
IF Frequency	DC	130/380	500	MHz	
Differential Input Impedance	220	260	300	Ω	IF=130MHz
IF to RF Output Isolation		30		dB	
IF to LO Isolation		30		dB	
LO Input					
LO Frequency Range		300 to 2700		MHz	
LO Level		-6 to 0		dBm	
LO to RF Output Leakage	-18	-25		dBm	At Cellular band, high side injection (Dual-Output board)
	-15	-17		dBm	At PCS band, low side injection (Dual-Output board)
	-14	-15		dBm	
RF to LO Isolation		30		dB	
LO Input VSWR		2:1			50Ω
Power Supply					
Voltage	2.7	3.0	3.3	V	
Current Consumption		25		mA	

Pin	Function	Description	Interface Schematic
1	IF-	Balanced IF input pin. This pin is internally DC-biased and should be DC-blocked if connected to a device with a DC level present. For single-ended input operation, one pin is used as an input and the other IF input is AC-coupled to ground. The balanced, input impedance is 260Ω.	
2	IF+	Same as pin 1, except complementary input.	See pin 1.
3	BYP	Bypass pin for internal bias circuitry. Bypass with a 1 nF capacitor.	
4	LO-	Balanced LO input pin. This pin is internally DC-biased and should be DC-blocked if connected to a device with a DC level present. For single-ended input operation, one pin is used as an input and the other LO input is AC-coupled to ground.	
5	LO+	Same as pin 4, except complementary input.	See pin 4.
6	GND	Ground connection. For best performance, keep traces physically short and connect immediately to ground plane.	
7	VCC	Supply voltage pin. External bypassing is required. External RF, LO, and IF bypassing is required. The trace length between the pin and the bypass capacitors should be minimized. The ground side of the bypass capacitors should connect immediately to ground plane.	
8	RF OUT	RF output pin.	

RF2638

Application Schematic 836MHz

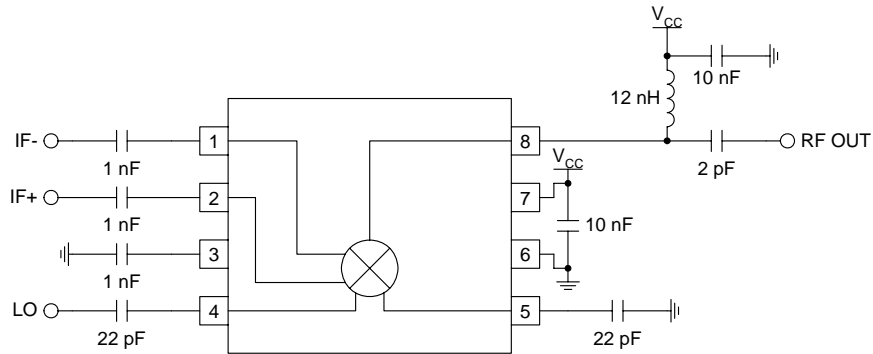

Application Schematic 1880MHz

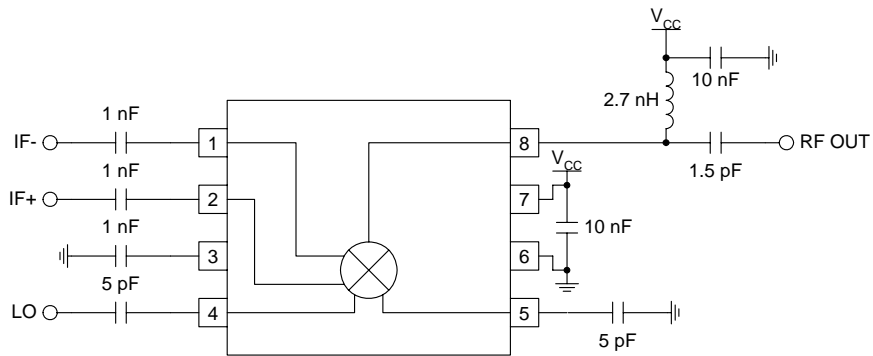

**Application Schematic
Dual-Band Output (836MHz/1880MHz)**

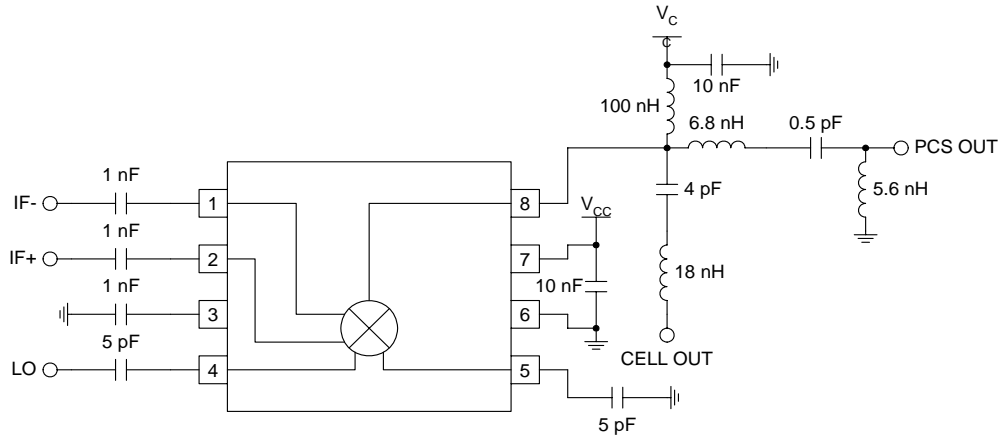

**Application Schematic
W-CDMA (1950MHz)**

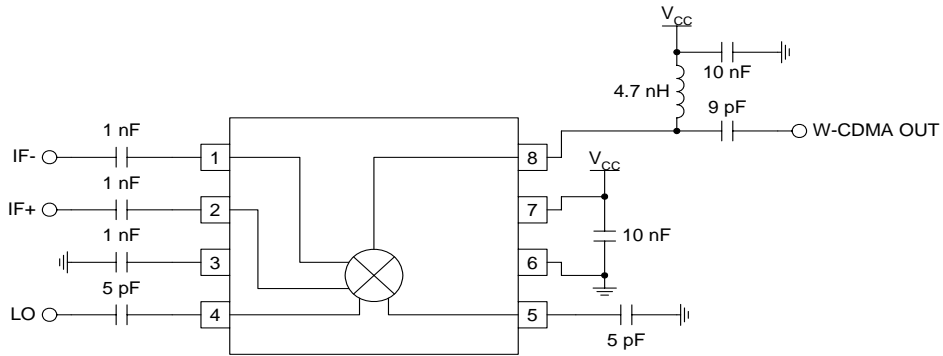

RF2638

Evaluation Board Schematic - PCS/Cellular

RF = 1880MHz, IF = 130MHz

(Download [Bill of Materials](http://www.rfmd.com) from www.rfmd.com.)

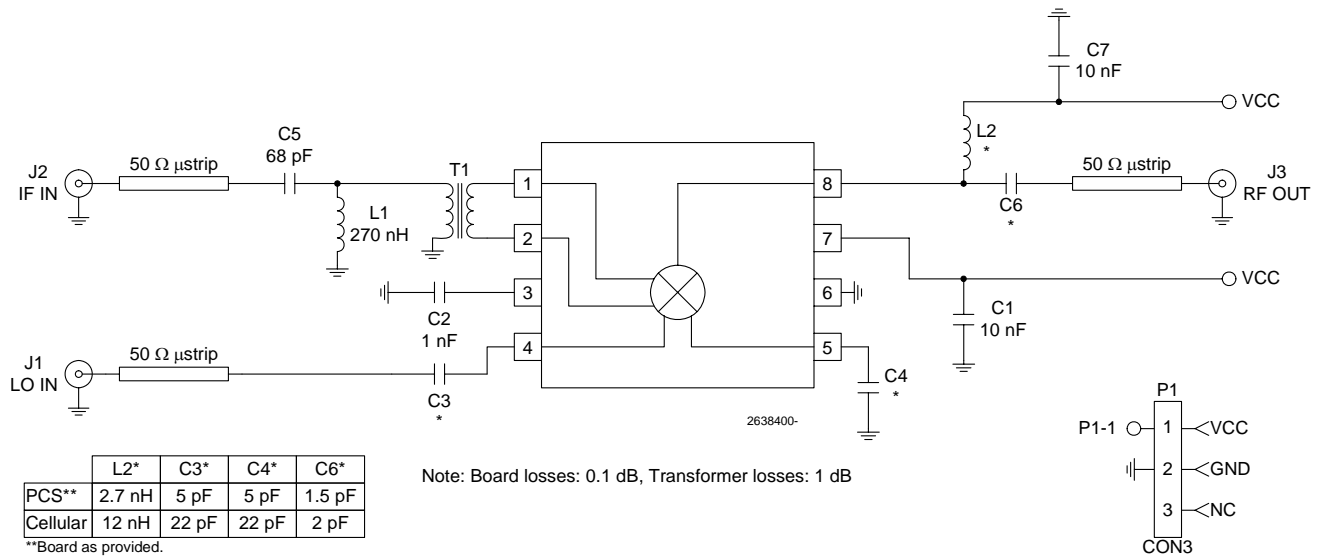

Evaluation Board Schematic - Dual Output

Cellular Out=836MHz, PCS Out=1880MHz, IF = 130MHz

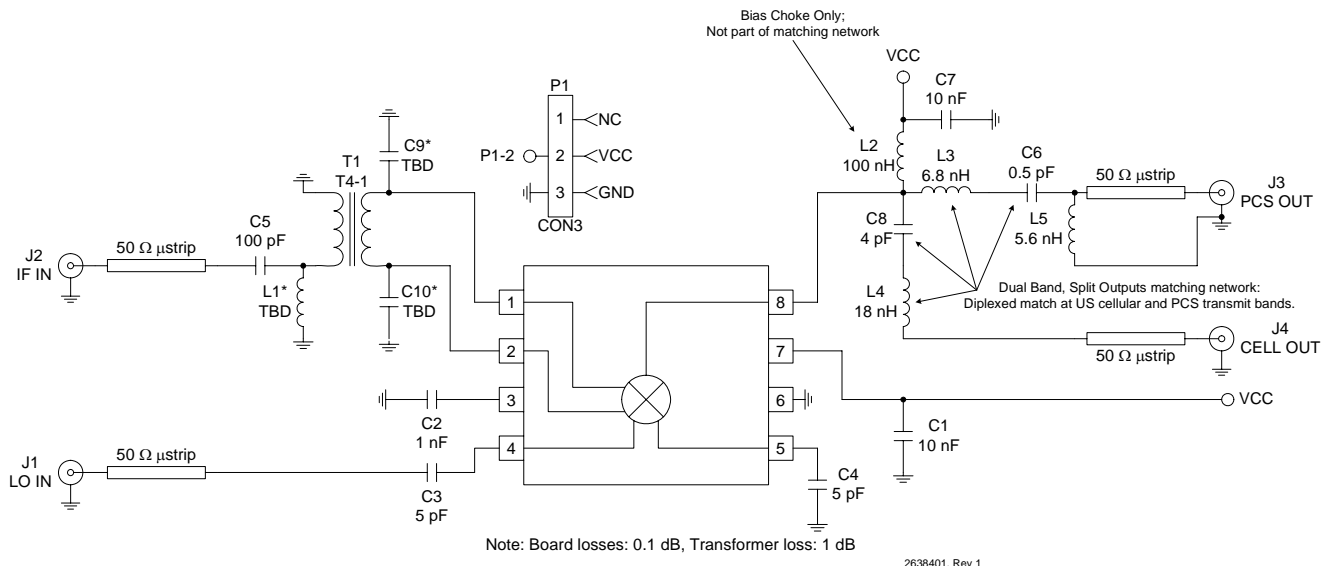

Evaluation Board Schematic - W-CDMA RF = 1950MHz, IF = 380MHz

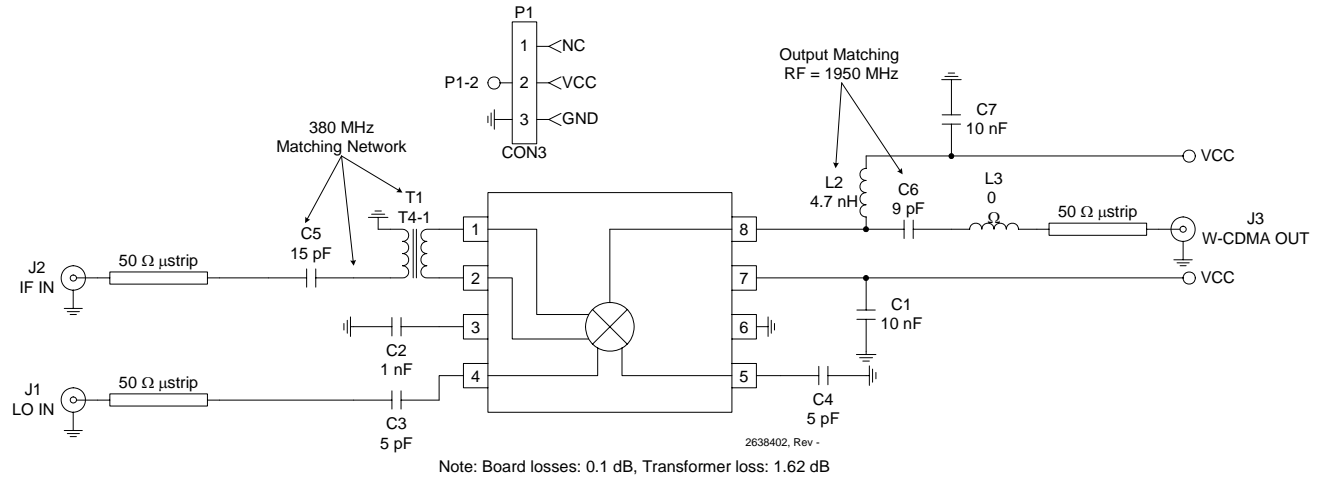

RF2638

Evaluation Board Layout
PCS/Cellular
Board Size 2.0" x 2.0"
Board Thickness 0.031", Board Material FR-4

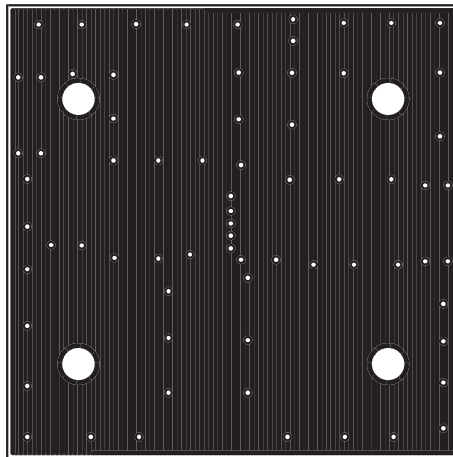
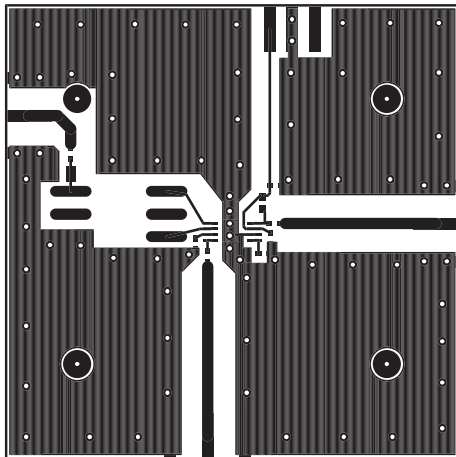
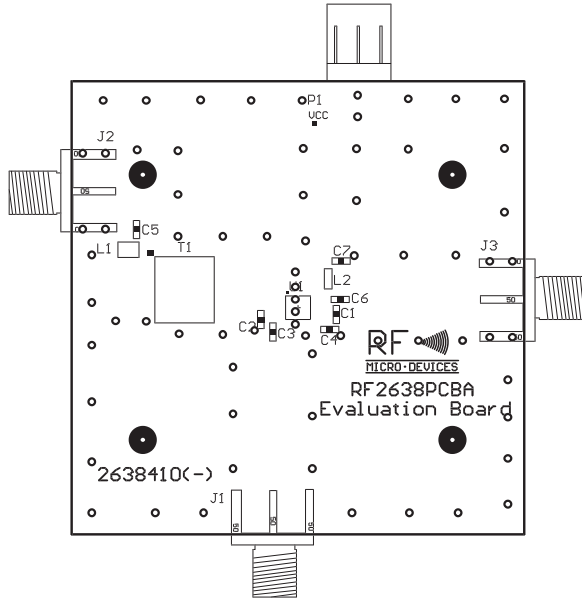

Evaluation Board Layout
Dual Output
Board Size 2.5" x 1.0"

Board Thickness 0.060", Board Material FR-4, Multi-Layer
(Intermediate layers (Ground Plane and Power Plane [V_{CC1}]) are not shown.)

