

April 2005

Features

- 12x10 Gb/s Integrated Transimpedance and Limiting Amplifier for parallel channel optical receiver applications
- Channels support data rates up to 10.7 Gb/s enabling various 120 Gb/s parallel PMD applications
- Global signal detect senses quiescent photocurrent with adjustable threshold and hysteresis
- Individual channel signal detect senses input signal strength (OMA) with adjustable sensitivity and hysteresis
- 20 μA_{pp} receiver sensitivity for 10^{-12} BER
- 180 mW per channel power dissipation for >500 mV differential output swing
- Serial digital interface for controlling channel power down, signal detect sensitivity, output amplitude and global signal detect
- Differential back-terminated outputs
- Flip-chip or direct wire-bond attach to photodiode
- 250-micron channel pitch matches optical ribbon fiber and array photodiodes

Applications

- Proprietary 120Gb/s intra-system parallel optics
- Multi-channel 10GbE, 10GFC, OC-192 VSR optical links

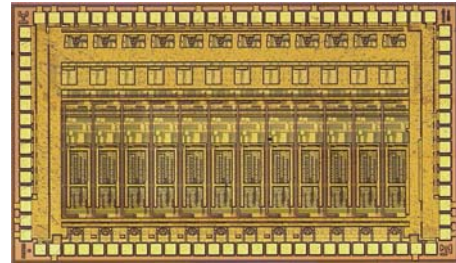

Description

The growing use of the Internet has created increasingly higher demand for multi-Gb/s I/O performance. The demand for 100+ Gb/s WAN bandwidth fuels the growth of short-reach 120 Gb/s infrastructures within high-end telco and datacom routers, switches, servers and other proprietary chassis-to-chassis links. The Zarlink PX6429 120 GB/s TIA/LA Receiver is a 12-channel TIA/LA optical receiver designed for various 12x10 Gb/s, 10 Gb/s parallel optics and CWDM PMD applications. It consists of a DC coupled transimpedance amplifier and an AC coupled differential limiting amplifier.

The transimpedance amplifier achieves a nominal 8 GHz bandwidth over a wide range of photodiode input capacitance. Excellent channel-to-channel isolation ensures data integrity at the receiver sensitivity limits. A global signal detect circuit provides the photodiode reverse bias voltage supply and senses average photocurrent supplied to the photodiode array.

The transimpedance amplifier is AC-coupled internally to a high-gain, high-bandwidth differential limiting amplifier. The limiting amplifier provides a differential back-terminated CML output that can be used to drive 10 Gb/s per channel transceivers or other CML compatible clock and data recovery circuits. The limiting amplifier features an adjustable signal detect circuit that senses optical modulation amplitude (OMA) to provide a received signal indication for each channel.

Figure 1: Typical optical to electrical differential data eye from the Zarlink PX6429 IC using a commercially available photodiode at 10 Gb/s with a PRBS31 data pattern.

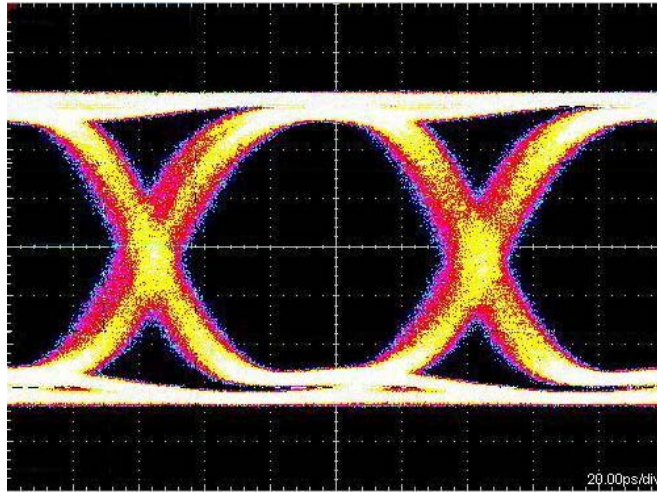
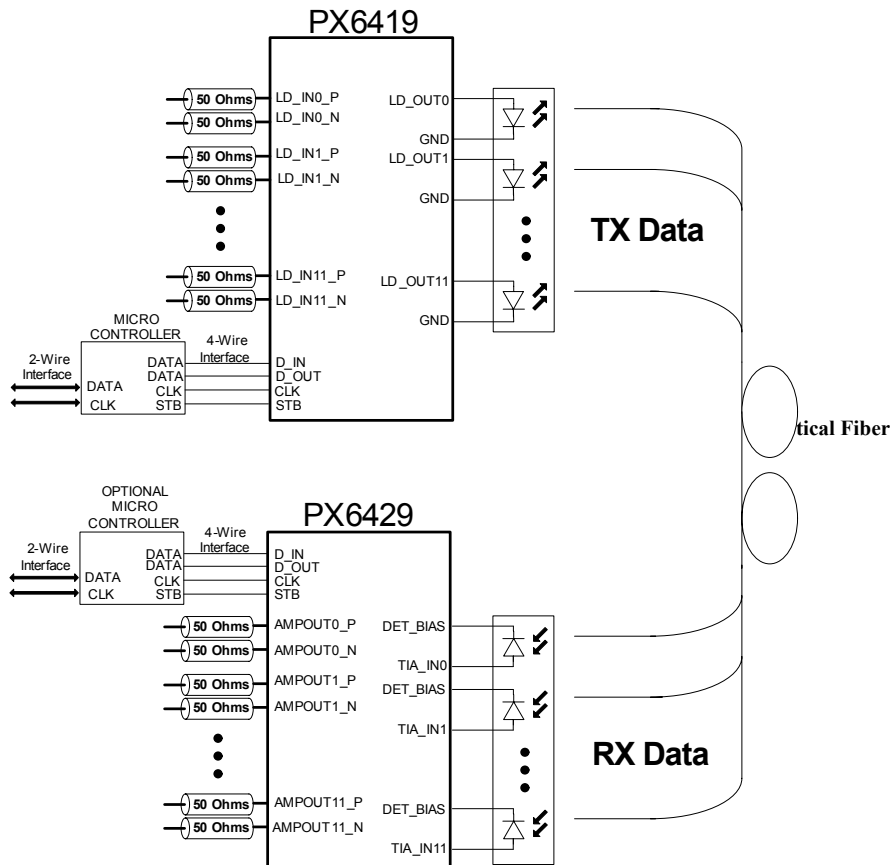

Figure 2: Application Block Diagram





**For more information about all Zarlink products
visit our Web Site at
www.zarlink.com**

Information relating to products and services furnished herein by Zarlink Semiconductor Inc. or its subsidiaries (collectively "Zarlink") is believed to be reliable. However, Zarlink assumes no liability for errors that may appear in this publication, or for liability otherwise arising from the application or use of any such information, product or service or for any infringement of patents or other intellectual property rights owned by third parties which may result from such application or use. Neither the supply of such information or purchase of product or service conveys any license, either express or implied, under patents or other intellectual property rights owned by Zarlink or licensed from third parties by Zarlink, whatsoever. Purchasers of products are also hereby notified that the use of product in certain ways or in combination with Zarlink, or non-Zarlink furnished goods or services may infringe patents or other intellectual property rights owned by Zarlink.

This publication is issued to provide information only and (unless agreed by Zarlink in writing) may not be used, applied or reproduced for any purpose nor form part of any order or contract nor to be regarded as a representation relating to the products or services concerned. The products, their specifications, services and other information appearing in this publication are subject to change by Zarlink without notice. No warranty or guarantee express or implied is made regarding the capability, performance or suitability of any product or service. Information concerning possible methods of use is provided as a guide only and does not constitute any guarantee that such methods of use will be satisfactory in a specific piece of equipment. It is the user's responsibility to fully determine the performance and suitability of any equipment using such information and to ensure that any publication or data used is up to date and has not been superseded. Manufacturing does not necessarily include testing of all functions or parameters. These products are not suitable for use in any medical products whose failure to perform may result in significant injury or death to the user. All products and materials are sold and services provided subject to Zarlink's conditions of sale which are available on request.

Purchase of Zarlink's I²C components conveys a licence under the Philips I²C Patent rights to use these components in and I²C System, provided that the system conforms to the I²C Standard Specification as defined by Philips.

Zarlink, ZL and the Zarlink Semiconductor logo are trademarks of Zarlink Semiconductor Inc.

Copyright Zarlink Semiconductor Inc. All Rights Reserved.

TECHNICAL DOCUMENTATION - NOT FOR RESALE
