

### Applications

- Bluetooth™ wireless technology (Class 1)
- USB dongles
- PCMCIA, flash cards
- Access points
- 2.4 GHz cordless telephone

### Features

- +22.5 dBm Output Power
- Low current 108 mA typical @  $P_{OUT} = +20$  dBm
- CMOS Enable Interface
- Power-control and power-down modes
- 3.3 V single supply operation
- Thin, lead-free 6 pin QFN package

### Ordering Information

Part Number	Package	Remark
PA2423U	6 pin QFN (0.5 mm height)	Samples
PA2423U-R	6 pin QFN (0.5 mm height)	Tape & Reel
PA2423U-EV1	Evaluation Kit	

### Product Description

A monolithic, high-efficiency, silicon-germanium power amplifier IC, the PA2423U is designed for 2.4 GHz wireless applications, including Bluetooth™ Class1 and 2.4 GHz cordless telephone applications. It delivers +22.5 dBm output power making it capable of overcoming insertion losses of up to 2.5 dB between amplifier output and antenna input.

The PA2423U provides a digital control input for controlling power up and power down modes of operation.

The PA2423U operates at 3.3 V DC. At typical output power level (+22.5 dBm), the current consumption is 135 mA.

The silicon/silicon-germanium structure of the PA2423U, and its exposed die-pad package, soldered to the system PCB, provide high thermal conductivity and a subsequently low junction temperature. This device is capable of operating at a duty cycle of 100 percent. The device is pin for pin compatible to the PA2423L.

### Functional Block Diagram

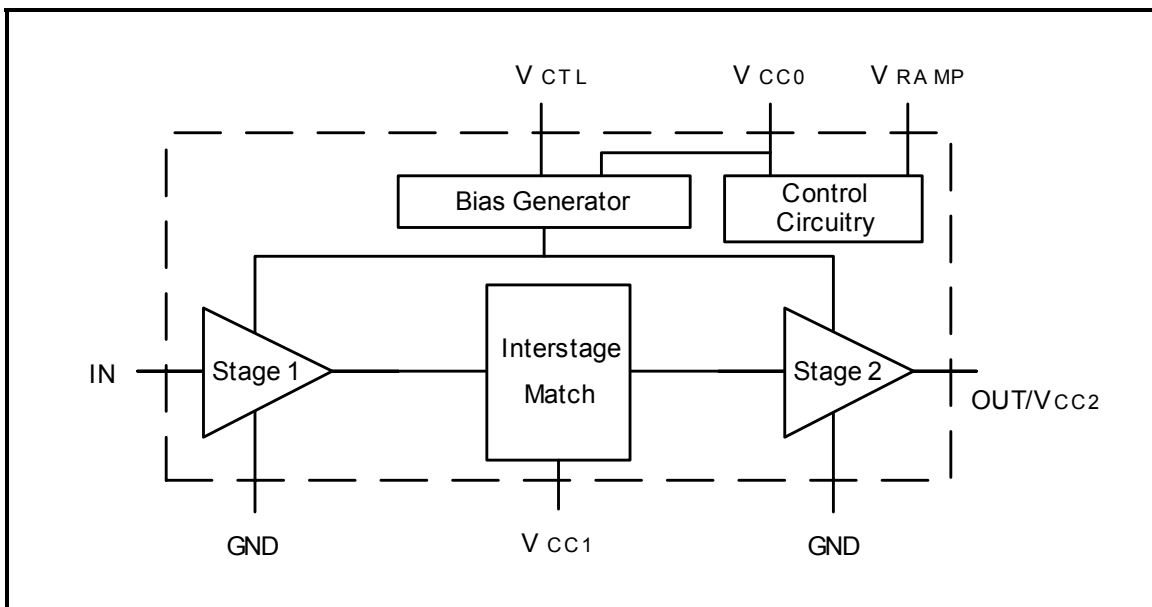
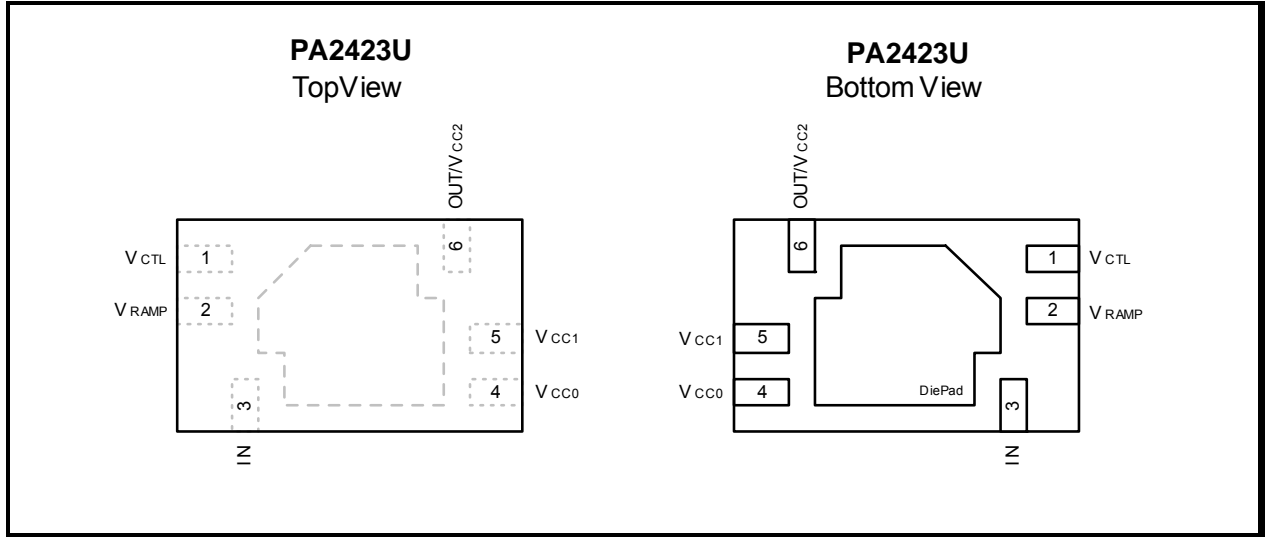

Figure 1: PA2423U Block Diagram

### Pin-Out Diagram



**Figure 2: PA2423U Pin-Out**

### Pin Out Description

Pin No.	Name	Description
1	V <sub>CTL</sub>	Controls the output level of the power amplifier. An analog control signal between 0 V and V <sub>CC</sub> varies the PA output power between minimum and maximum values
2	V <sub>RAMP</sub>	Power Amplifier Enable pin. A digital control signal with logic high (power up) and logic low (power down) is used to turn the device on and off.
3	IN	Power amplifier RF input, external input matching network with DC blocking is required
4	V <sub>CC0</sub>	Bias supply voltage
5	V <sub>CC1</sub>	Stage 1 collector supply voltage, external inter-stage matching network is required
6	OUT/V <sub>CC2</sub>	PA Output and Stage2 collector supply voltage, external output matching network with DC blocking is required
Die Pad	GND	Heatslug Die Pad is ground

### Absolute Maximum Ratings

Operation in excess of any one of above Absolute Maximum Ratings may result in permanent damage. This device is ESD sensitive. Handling and assembly of this device should be at ESD protected workstations.

Symbol	Parameter	Min.	Max.	Unit
V <sub>CC</sub>	Supply Voltage	-0.3	+3.6	V
V <sub>CTL</sub>	Control Voltage	-0.3	V <sub>CC</sub>	V
V <sub>RAMP</sub>	Ramping Voltage	-0.3	V <sub>CC</sub>	V
IN	RF Input Power	-	+8	dBm
T <sub>A</sub>	Operating Temperature Range	-40	+85	°C
T <sub>STG</sub>	Storage Temperature Range	-40	+150	°C
T <sub>j</sub>	Maximum Junction Temperature	-	+150	°C

### DC Electrical Characteristics

Conditions: V<sub>CC0</sub> = V<sub>CC1</sub> = V<sub>CC2</sub> = V<sub>RAMP</sub> = V<sub>CTL</sub> = 3.3 V, P<sub>IN</sub> = 0 dBm, T<sub>A</sub> = 25 °C, f = 2.45 GHz, input and output externally matched to 50Ω unless otherwise noted.

Symbol	Parameter	Min.	Typ.	Max.	Unit
V <sub>CC</sub>	Supply Voltage	2.7	3.3	3.6	V
I <sub>CC</sub>	Supply Current (I <sub>CC</sub> = I <sub>VCC0</sub> + I <sub>VCC1</sub> + I <sub>VCC2</sub> ), V <sub>CTL</sub> = 3.3 V, P <sub>OUT_MAX</sub> ≤ 22.5 dBm	-	135	160	mA
ΔI <sub>CCTEMP</sub>	Supply Current variation over temperature from T <sub>A</sub> = 25 °C (-40 °C < T <sub>A</sub> < +85 °C)	-	25	-	%
V <sub>CTL</sub>	PA Output Power Control Voltage Range	0	-	V <sub>CC</sub>	V
I <sub>CTL</sub>	Current sunk by V <sub>CTL</sub> pin	-	200	250	μA
V <sub>RAMP</sub>	Logic High Voltage	2.0	-	-	V
	Logic Low Voltage	-	-	0.8	V
I <sub>stdby</sub>	Leakage Current when V <sub>RAMP</sub> = 0 V, No RF, V <sub>CTL</sub> = high	-	0.5	10	μA

### AC Electrical Characteristics

Conditions:  $V_{CC0} = V_{CC1} = V_{CC2} = V_{RAMP} = V_{CTL} = 3.3\text{ V}$ ,  $P_{IN} = 0\text{ dBm}$ ,  $T_A = 25\text{ }^\circ\text{C}$ ,  $f = 2.45\text{ GHz}$ , input and output externally matched to  $50\Omega$  unless otherwise noted.

Symbol	Parameter	Min.	Typ.	Max.	Unit
$f_{L-U}$	Frequency Range	2400	-	2500	MHz
$P_{OUT\_MAX}$	Output Power @ $V_{CTL} = 3.3\text{ V}$	20.0	22.5	-	dBm
$P_{OUT\_MIN}$	Output Power @ $V_{CTL} = 0.4\text{ V}$	-	-20	0	dBm
$\Delta P_{temp}$	Output Power variation over temperature ( $-40\text{ }^\circ\text{C} < T_A < +85\text{ }^\circ\text{C}$ )	-	1	2	dB
$dP_{OUT}/dV_{CTL}$	Control Voltage Sensitivity	-	-	120	dBm/V
$G_{SS}$	Gain @ $P_{IN} = -25\text{ dBm}$	25.5	28.5	-	dB
$G_{VAR}$	Gain Variation over band (2400-2500 MHz)	-	0.2	1.0	dB
$2f$	Harmonics	-	-45	-30	dBc
$3f$		-	-40	-35	
$IS_{21OFF}$	Isolation in "OFF" State, $V_{RAMP} = 0\text{ V}$	15	36	-	dB
$IS_{12I}$	Reverse Isolation	32	42	-	dB
STAB	Stability ( $P_{IN} = 0\text{ dBm}$ , Load VSWR = 6:1)	All non-harmonically related outputs less than -50 dBc			

**Typical Performance Characteristics**

Test Conditions: SiGe PA2423U-EV1:  $V_{CC0} = V_{CC1} = V_{CC2} = V_{RAMP} = V_{CTL} = 3.3\text{ V}$ ,  $P_{IN} = 0\text{ dBm}$ ,  $T_A = 25\text{ }^\circ\text{C}$ ,  $f = 2.45\text{ GHz}$ , input and output externally matched to  $50\Omega$  unless otherwise noted

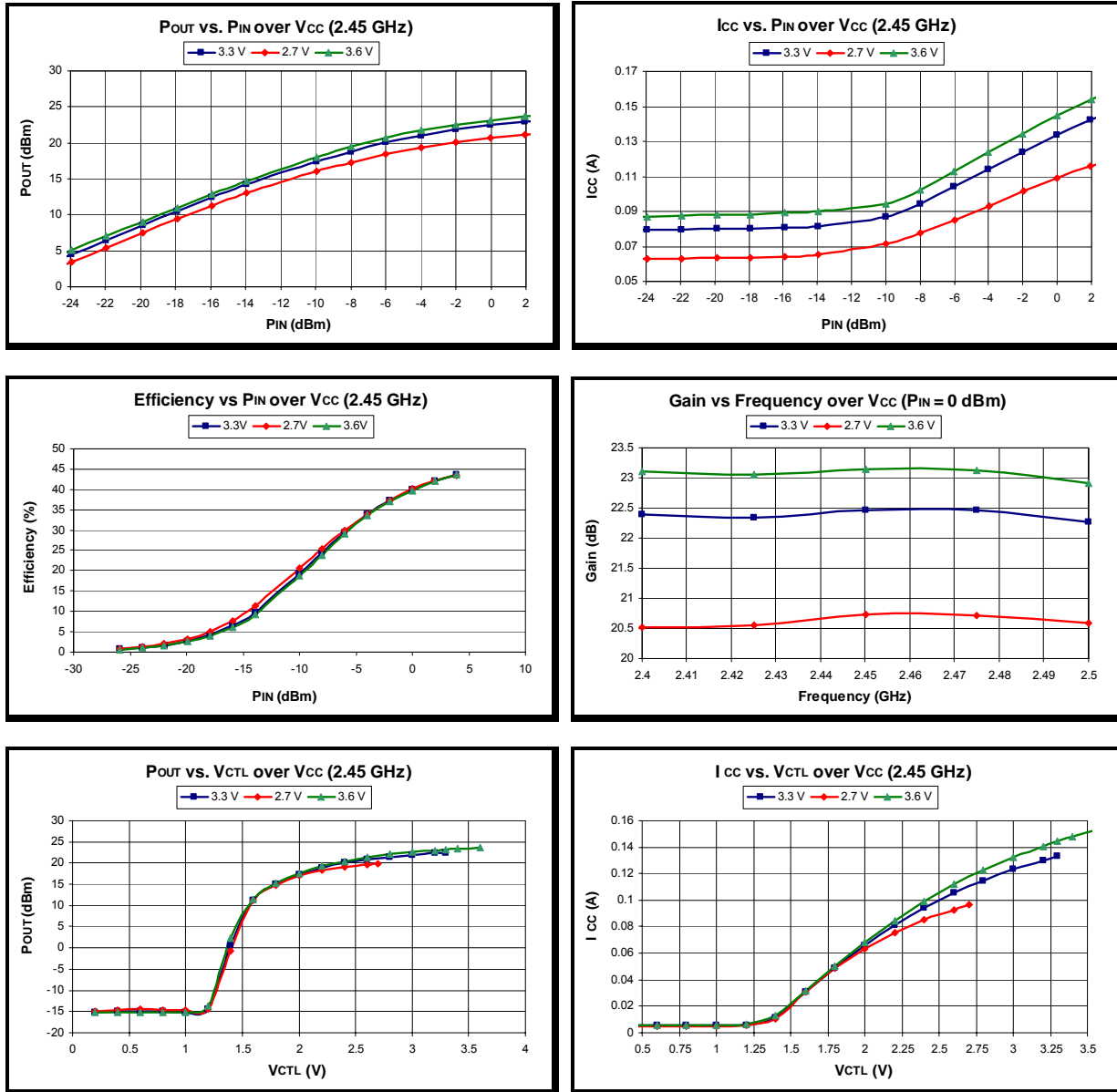

**Figure 3: PA2423U Typical Performance Characteristics**

**Typical Performance Characteristics (Continued)**

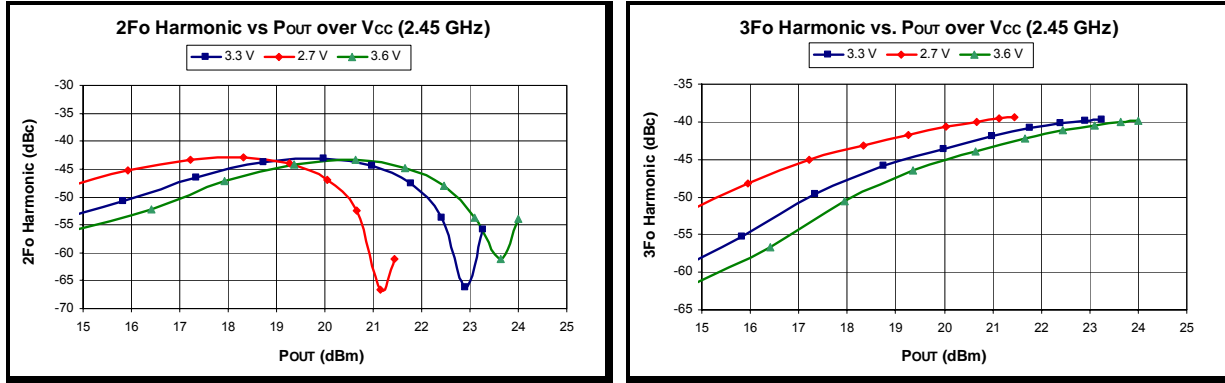

**Figure 4: PA2423U Typical Performance Characteristics (Continued)**

**Application Circuit**

Figure 5 is a representation of the PA2423U application circuit. For a detailed schematic and layout, refer to SiGe's PA2523U-EK1 Evaluation Kit Data Sheet (*Document Number: 131-DST-02*).

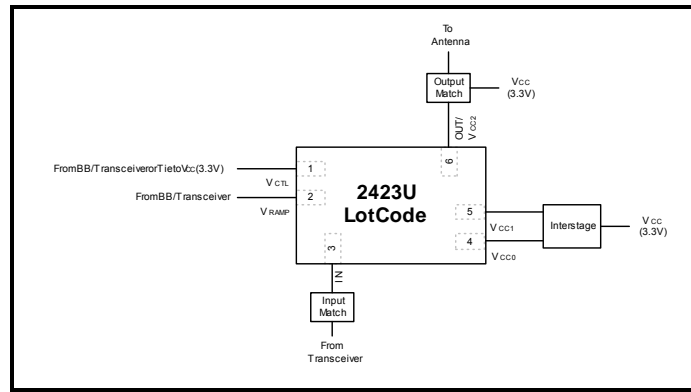

**Figure 5: PA2423U Application Circuit**

**Branding Information**

Figure 6 shows the branding for the PA2423U, including the Pin 1 location relative to the branding.

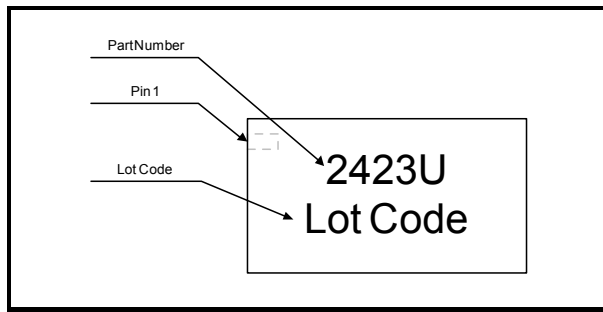

**Figure 6: PA2423U Branding Information**

**Tape and Reel Information**

Table 1 and Figure 7 show the PA2423U tape and reel information.

Parameter	Value
Reel Diameter	7 inches
Reel Width	8 mm
Units per Reel	3000

**Table 1: PA2423U Tape and Reel Information**

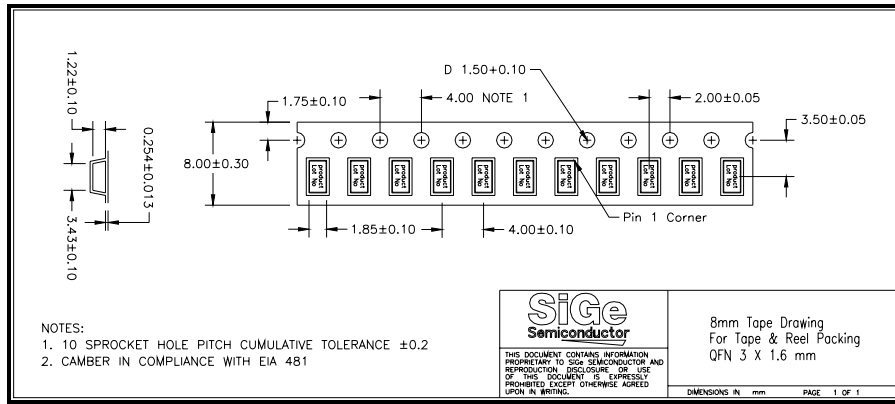

**Figure 7: PA2423U Tape and Reel Diagram**

**Package Dimensions**

The PA2423U is packaged in a 1.6 mm x 3.0 mm 6 pin QFN package, with a height of 0.5 mm. The detailed package drawing is shown in Figure 8. The underside of the package is an exposed die-pad structure. This allows for direct soldering to the PCB for enhanced thermal conductivity. The package dimensions are shown in the drawing below. The PA2423U is lead free.

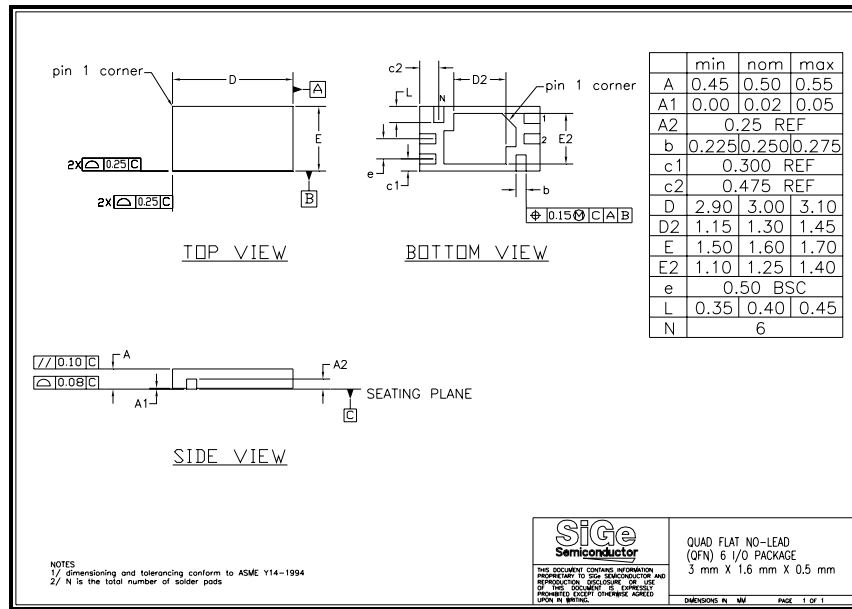

**Figure 8: PA2423U Package Drawing**

**Recommended Application PCB Footprint Layout**

Figure 9 shows SiGe's recommended PA2423U Application PCB footprint.

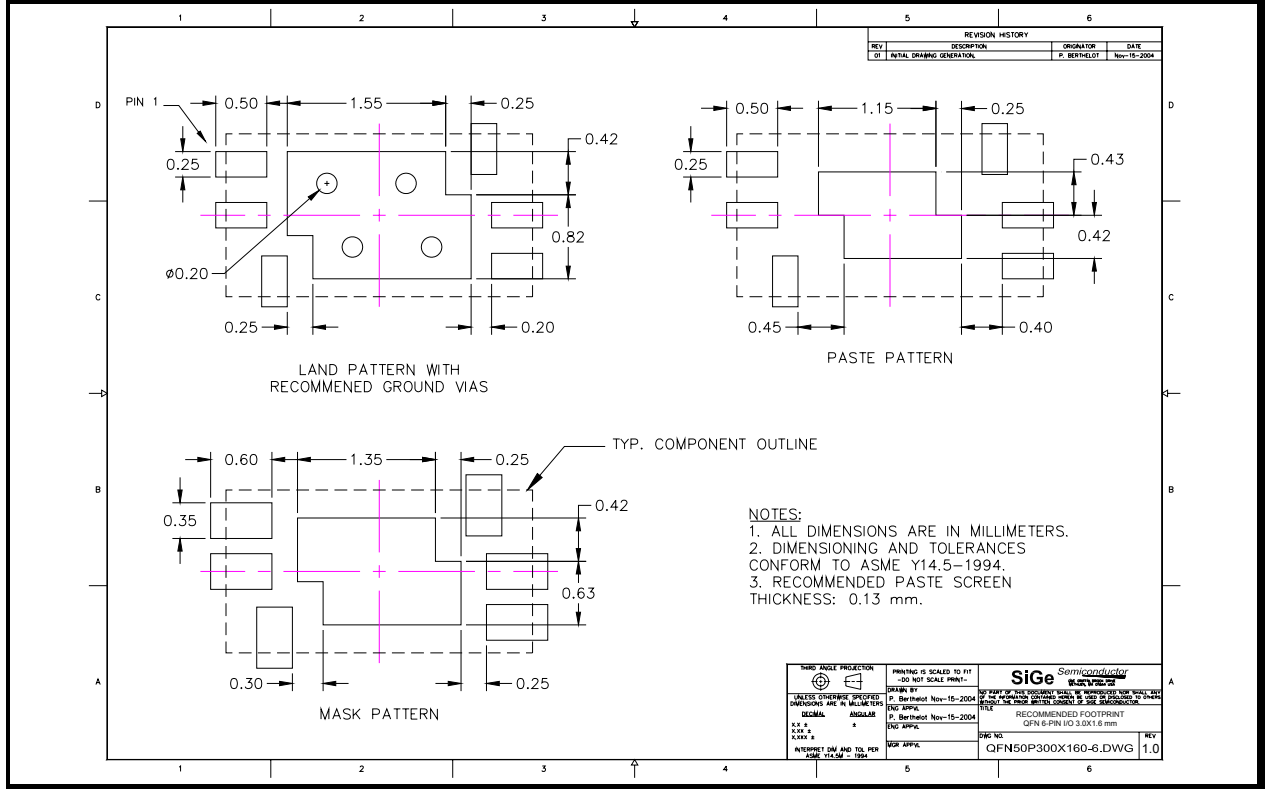

**Figure 9: PA2423U Recommended Application PCB Footprint**



---

## Applications Information

For test and design purposes, SiGe Semiconductor offers an evaluation board for the PA2423U. The order part number for the evaluation board is PA2423U-EV1. The evaluation board is intended to simplify the testing with respect to RF performance of this power amplifier.

The application note, 131-DST-02 provides the supporting information for using the evaluation board. It contains information on the schematic, bill of materials and recommended layout for the power amplifier and the input and output matching networks. To assist in the design process, this layout is available, upon request, in gerber file format.

### Using $V_{RAMP}$

$V_{RAMP}$  is a digital pin used to power-up and power-down the PA2423U in time division duplex systems such as Bluetooth™ 1.1. During receive mode,  $V_{RAMP}$  voltage is pulled down, PA2423U acts as a 35 dB isolation block between the radio and the antenna while consuming a modest 1  $\mu$ A. In transmit mode,  $V_{RAMP}$  voltage is pulled to  $V_{CC}$  and PA2423U offers 19 dB to 21 dB of large signal gain.

### Using $V_{CTL}$

$V_{CTL}$  is an analog pin that is designed to control the gain of PA2423U. Applying a voltage between 0 V and  $V_{CC}$  will adjust the gain between -15 dB and 21 dB. Used in combination with a variable drive level to PA2423U, the  $V_{CTL}$  function can greatly optimize the PAE of the system at all four Bluetooth™ transmitted power levels.

<http://www.sige.com>

**Email:           sales@sige.com**

**Customer Service Locations:**

North America:  
1050 Morrison Drive, Suite 100  
Ottawa ON K2H 8K7 Canada

Phone: +1 613 820 9244  
Fax:   +1 613 820 4933

Hong Kong  
Phone: +852 3428 7222  
Fax:   +852 3579 5450

San Diego  
Phone: +1 858 668 3541 (ext. 226)  
Fax:   +1 858 668 3546

United Kingdom  
Phone: +44 1264 850754  
Fax:   +44 1264 852601

Product Preview

The datasheet contains information from the product concept specification. SiGe Semiconductor, Inc. reserves the right to change information at any time without notification.

Preliminary Information

The datasheet contains information from the design target specification. SiGe Semiconductor, Inc. reserves the right to change information at any time without notification.

Production testing may not include testing of all parameters.

Information furnished is believed to be accurate and reliable and is provided on an "as is" basis. SiGe Semiconductor, Inc. assumes no responsibility or liability for the direct or indirect consequences of use of such information nor for any infringement of patents or other rights of third parties, which may result from its use. No license or indemnity is granted by implication or otherwise under any patent or other intellectual property rights of SiGe Semiconductor, Inc. or third parties. Specifications mentioned in this publication are subject to change without notice. This publication supersedes and replaces all information previously supplied. SiGe Semiconductor, Inc. products are NOT authorized for use in implantation or life support applications or systems without express written approval from SiGe Semiconductor, Inc.

RangeCharger™, StreamCharger™, and PointCharger™ are trademarks owned by SiGe Semiconductor, Inc.

Copyright 2006 SiGe Semiconductor, Inc.  
All Rights Reserved