

# DELPHI SERIES

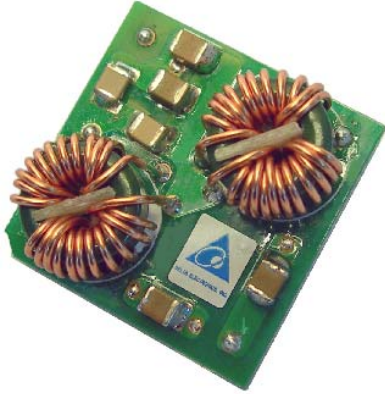

## FEATURES

- ◆ RoHS Compliant
- ◆ Small size: 25.4mm x 25.4mm x 12.0mm (1.0" x 1.0" x 0.47")
- ◆ Industry standard footprint and pin-out
- ◆ Surface mount or through hole pins
- ◆ Optimized for use with high frequency board mounted DC/DC converters
- ◆ Printed-circuit board mountable
- ◆ ISO 9001, TL 9000, ISO 14001, QS 9000, OHSAS 18001 certified manufacturing facility
- ◆ UL/cUL 60950 (US & Canada) Recognized, VDE 0805 (IEC60950) Licensed

## Delphi Series Filter Module - FL75L07 0~75Vdc input, 7A Current Rating

The Delphi series FL75L07 filter module is the latest offering from a world leader in power systems technology and manufacturing – Delta Electronics, Inc. This filter module is designed to reduce the conducted common-mode and differential-mode noise on input or output lines of high-frequency switching power supplies and has a maximum current rating of 7A. It has the industry standard footprint and pin-out. With creative design technology and optimization of component placement, Delphi FL75L07 filter module possesses outstanding electrical and thermal performance, as well as extremely high reliability under highly stressful operating conditions.

## APPLICATIONS

- ◆ Common-mode and differential-mode filtering of power supply dc input and output line
- ◆ Computer application
- ◆ Communications equipment

## SPECIFICATIONS

GENERAL SPECIFICATIONS			OUTPUT SPECIFICATIONS		
Input voltage, operation	Typical	0~75V	Common-mode Insertion Loss	50Ω circuit, 500 kHz (Typ)	40dB
Input voltage, continuous	Typical	0~100V	Differential-mode Insertion Loss	50Ω circuit, 500 kHz (Typ)	70dB
Operating temperature	Typical	-40°C ~ 115°C			
Storage temperature	Typical	-55°C ~ 125°C			
Size	(1.0" x 1.0" x 0.47")	25.4 x 25.4 x 12.0 mm			

## ELECTRICAL CHARACTERISTICS CURVES

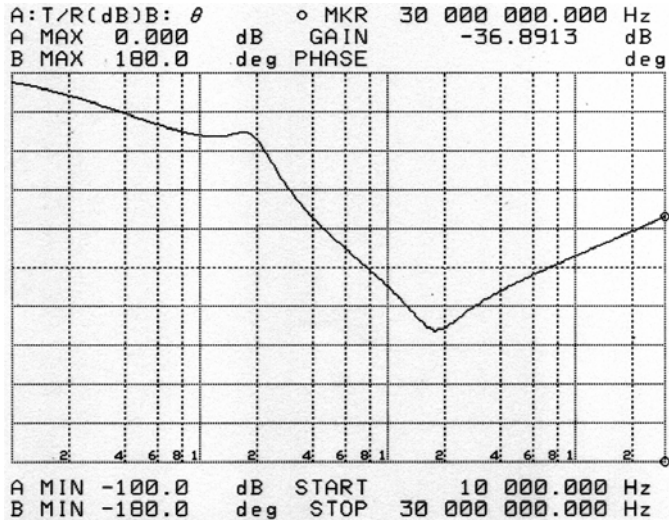

Figure 1: Typical common-mode insertion loss in a 50Ω circuit

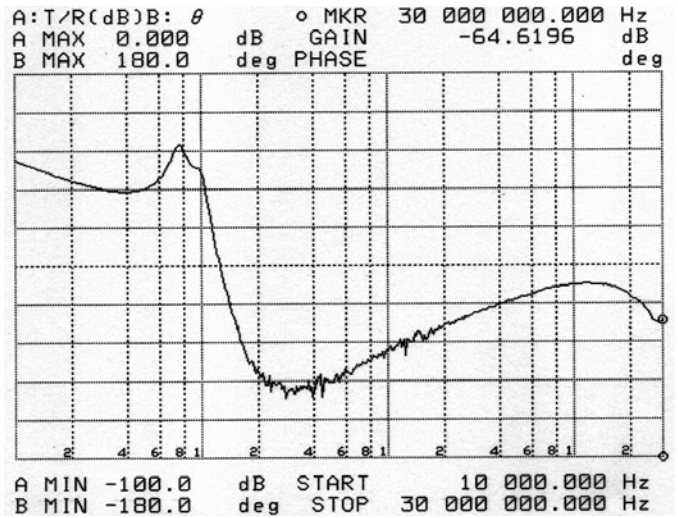

Figure 2: Typical differential-mode insertion loss in a 50Ω circuit

## Internal Schematics

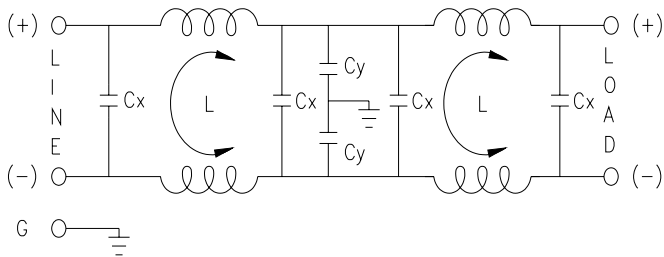

Figure 3: Internal schematics

## THERMAL CONSIDERATIONS

Thermal management is an important part of the system design. To ensure proper, reliable operation, sufficient cooling of the power module is needed over the entire temperature range of the module. Convection cooling is usually the dominant mode of heat transfer.

Hence, the choice of equipment to characterize the thermal performance of the power module is a wind tunnel.

### Thermal Testing Setup

Delta's filter modules are characterized in heated vertical wind tunnels that simulate the thermal environments encountered in most electronics equipment. This type of equipment commonly uses vertically mounted circuit cards in cabinet racks in which the power modules are mounted.

The following figure shows the wind tunnel characterization setup. The filter module is mounted on a test PWB and is vertically positioned within the wind tunnel. The space between the neighboring PWB and the top of the power module is 6.35mm (0.25").

### Thermal Derating

Heat can be removed by increasing airflow over the module. Figure 4 shows maximum output is a function of ambient temperature and airflow rate. To enhance system reliability, the power module should always be operated below the maximum operating temperature. If the temperature exceeds the maximum module temperature, reliability of the unit may be affected.

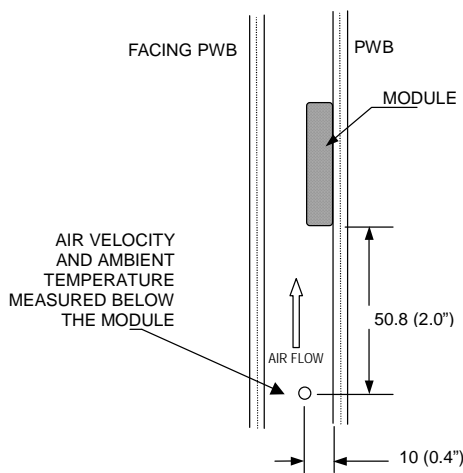

Note: Wind Tunnel Test Setup Figure Dimensions are in millimeters and (Inches)

Figure 4: Wind tunnel test setup

## THERMAL CURVES

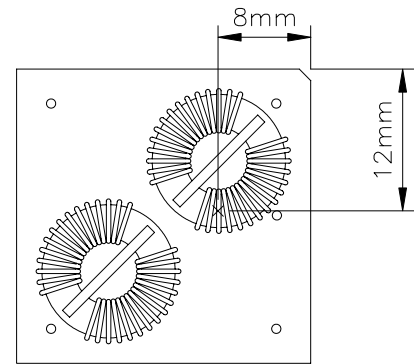

Figure 5: Temperature measurement location  
The allowed maximum hot spot temperature is defined at 115°C

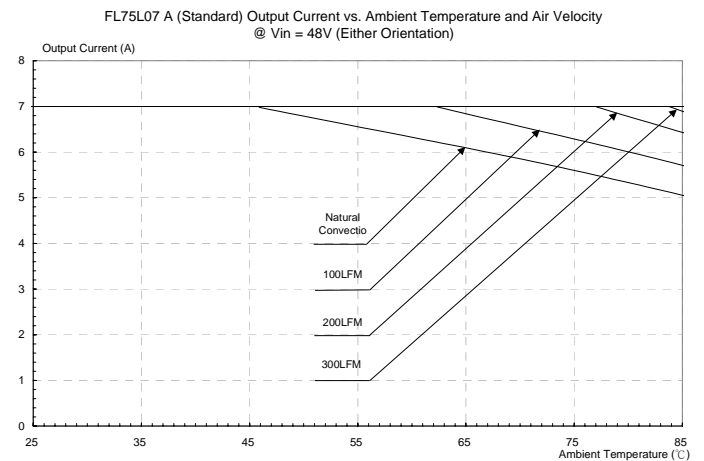
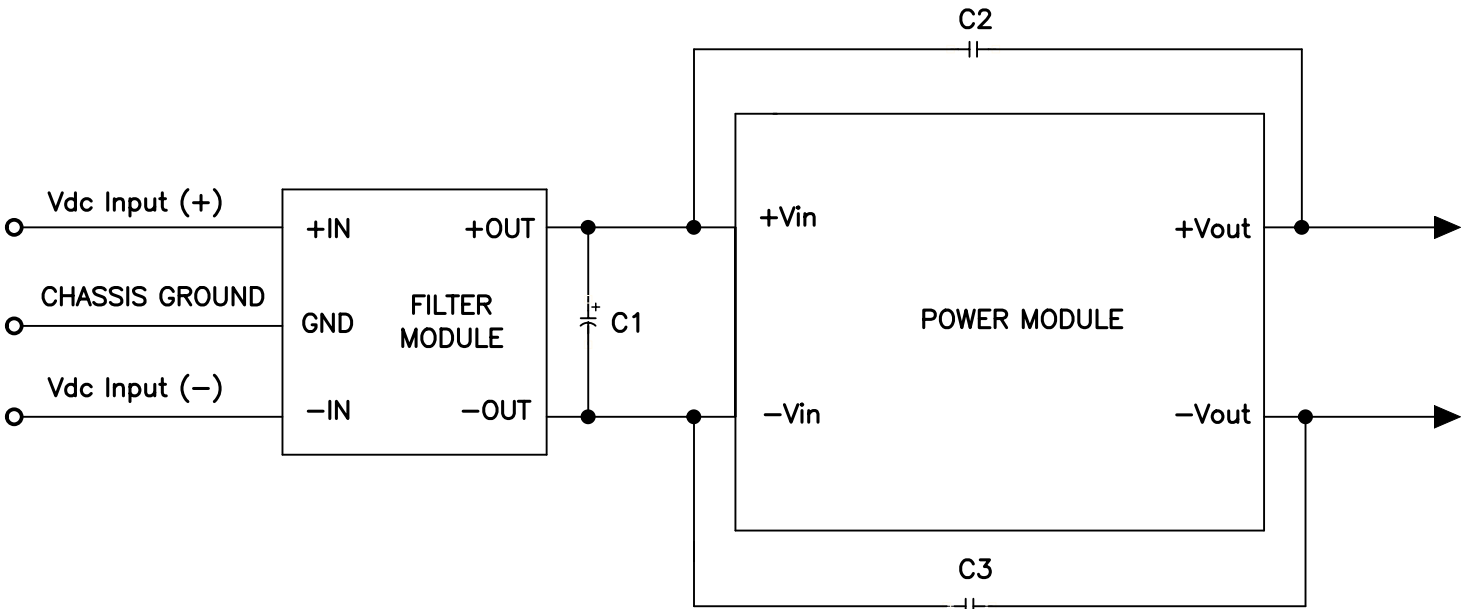

Figure 6: Output Current vs. Ambient Temperature and Air Velocity @ Vin = 48V (Either Orientation)

# APPLICATION



Note: C2 & C3 can be  $0.01 \mu\text{F}$  to  $0.1 \mu\text{F}$ . Select the voltage rating to meet input-to-output isolation requirements. C1 should be the recommended value suggested in the power module data sheet.

**Figure 7.** Recommended schematic when used as the input filter to a high-frequency with open-frame dc-to-dc converter

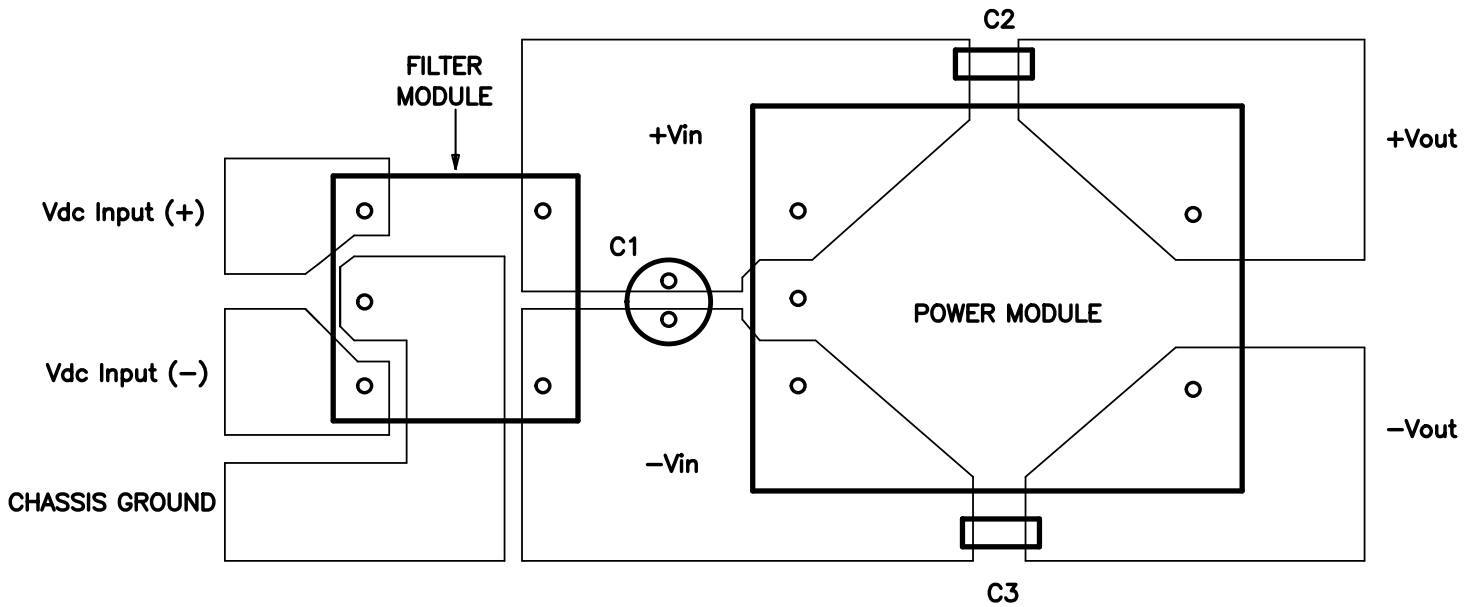

Note: Avoid routing signals or planes under the power module or the filter module. Please ensure all connections are low impedance.

**Figure 8.** Recommended layout when used as the input filter to a high-frequency with open-frame dc-to-dc converter

## APPLICATION (Continued)

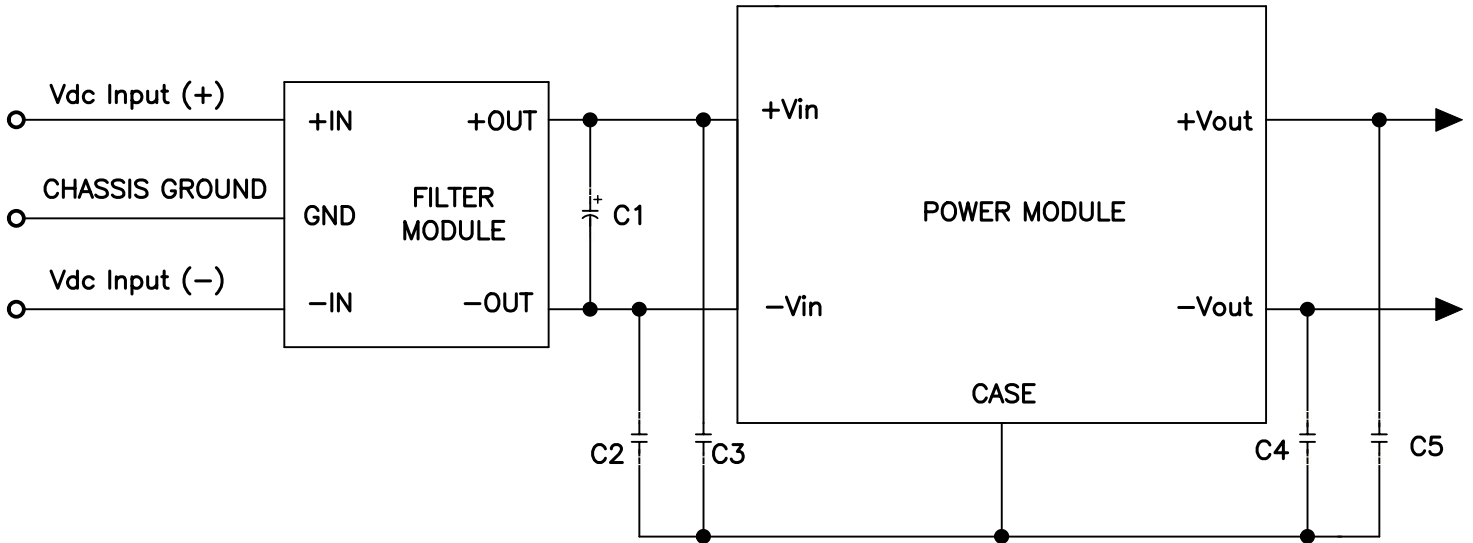

Note: C2 through C5 can be  $0.01 \mu\text{F}$  to  $0.1 \mu\text{F}$ . Select the voltage rating to meet input-to-output isolation requirements. C1 should be the recommended value suggested in the power module data sheet.

**Figure 9.** Recommended schematic when used as the input filter to a high-frequency with metal-cased dc-to-dc converter

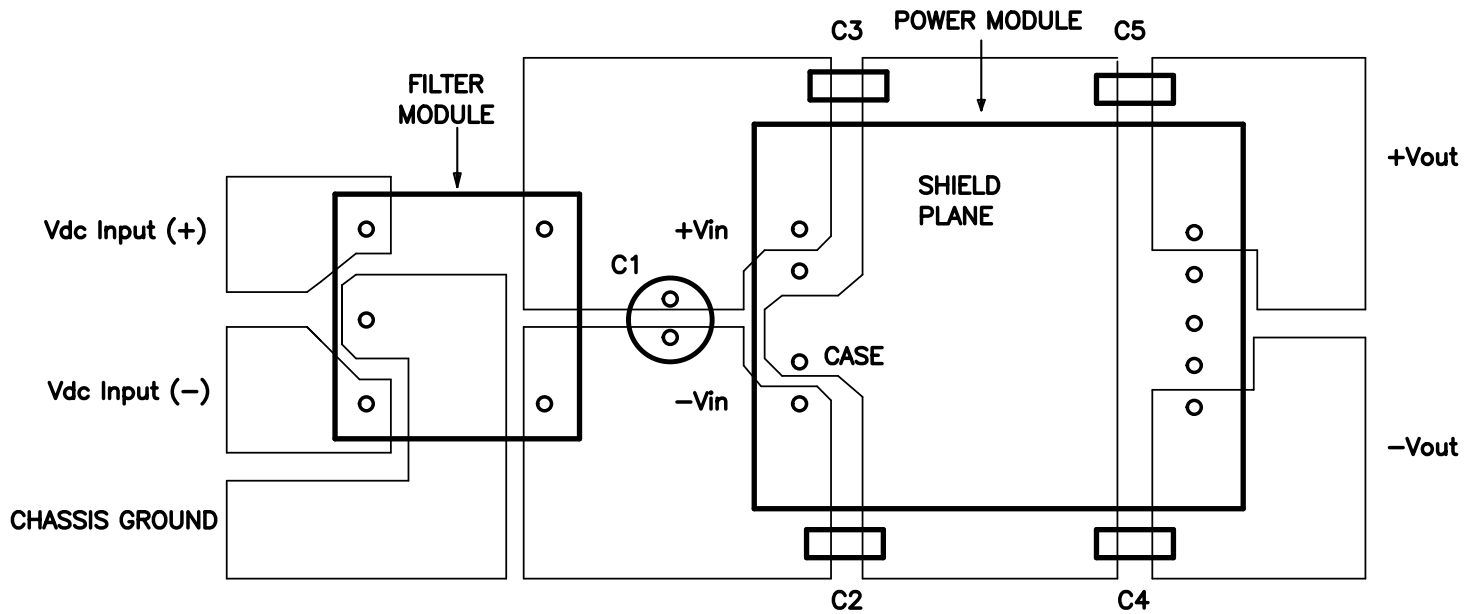

Note: Avoid routing signals or planes under the power module or the filter module. Please ensure all connections are low impedance.

**Figure 10.** Recommended layout when used as the input filter to a high-frequency with metal-cased dc-to-dc converter

## APPLICATION (Continued)

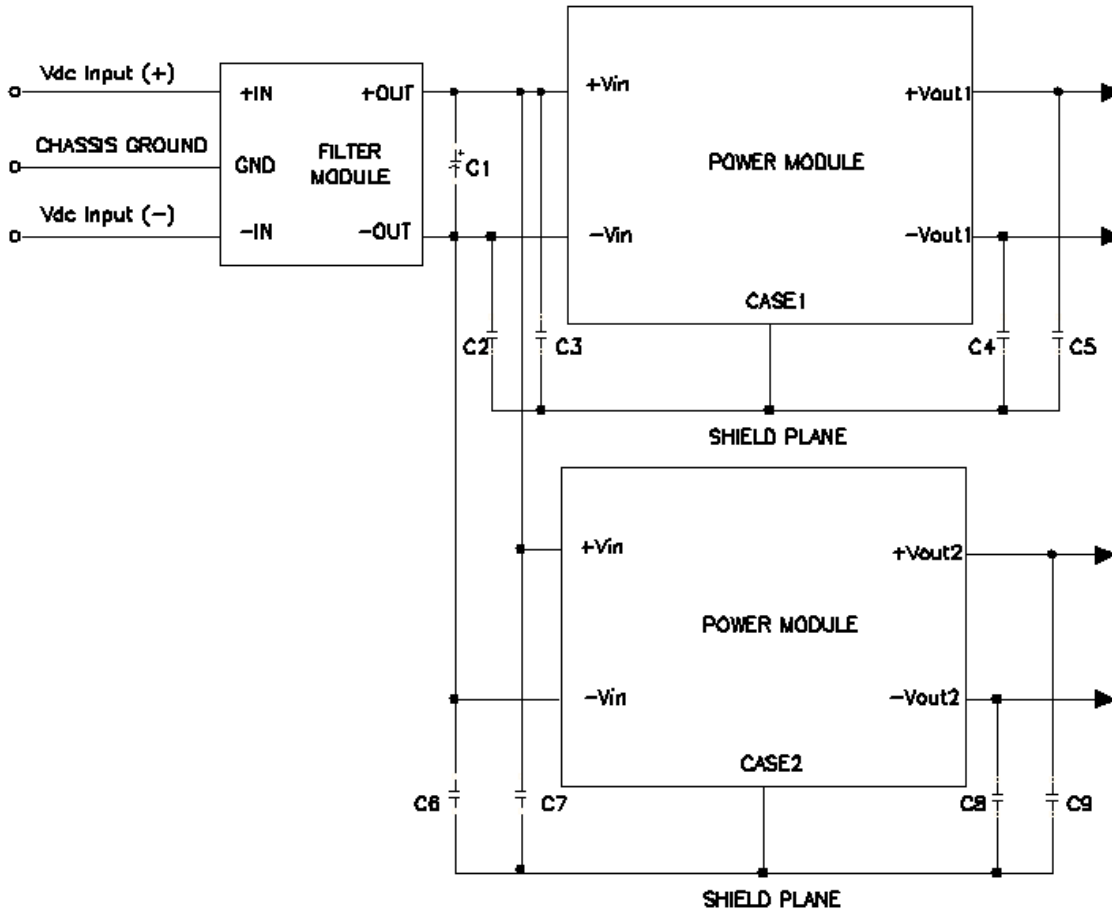

Note: : C2 through C5 and C6 through C9 can be  $0.01 \mu\text{F}$  to  $0.1 \mu\text{F}$ . Select the voltage rating to meet input-to-output isolation requirements. C1 should be the recommended value suggested in the power module datasheet.

**Figure 11.** Recommended schematic of filter module with two power modules ( metal -cased )



Figure 12 shows the experimental result obtained by using this filter module, together with the recommended external components shown in Figures 7 and 8. The Q48SB12025NR A module is one of the Delphi series quarter brick 12V, 25A DCDC converters. Measured noise is greatly dependent on layout, grounding, cable orientation, and load characteristics and the variation is possible from various application conditions.

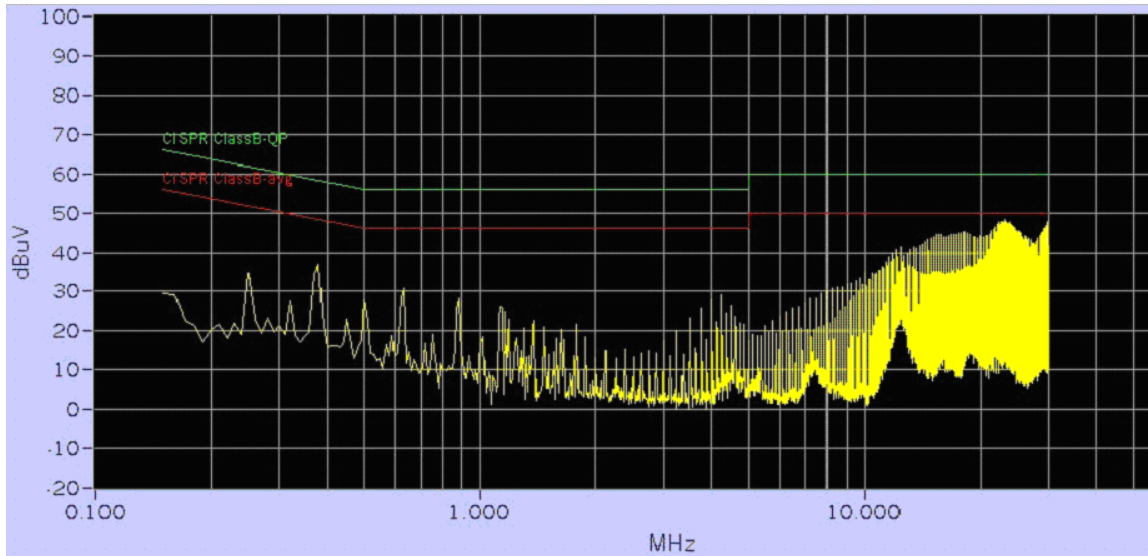
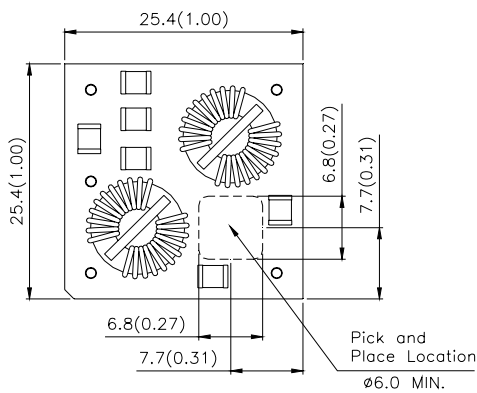

Figure 13. Q48SB12025NR A conducted noise with FL75L07A input filter

## MECHANICAL DRAWING

Top View



Side View

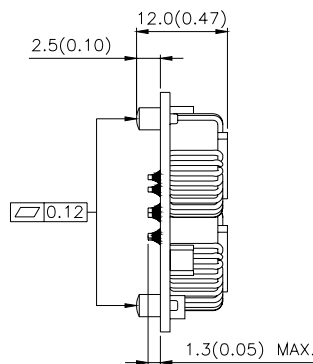

Bottom View

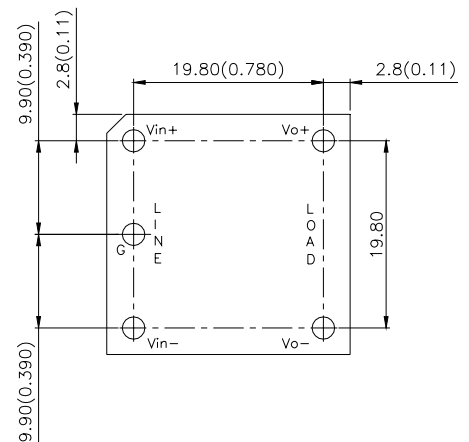

Dimensions are in millimeter

Tolerances : x.xx ± 0.5 mm (0.02 in), x.xxx ± 0.25 mm (0.010 in)

## PICK AND PLACE LOCATION

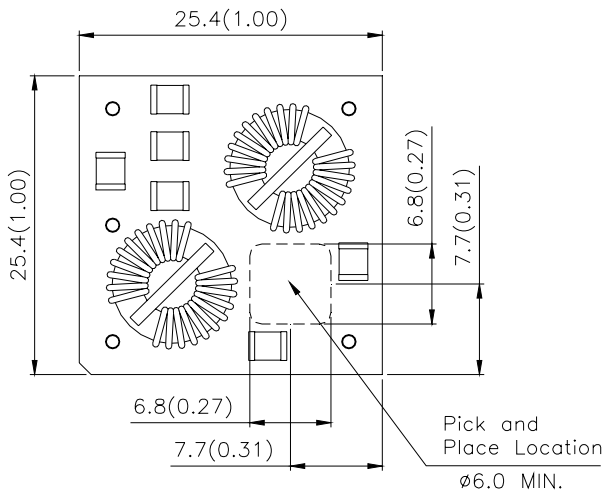

## SURFACE-MOUNT TAPE & REEL

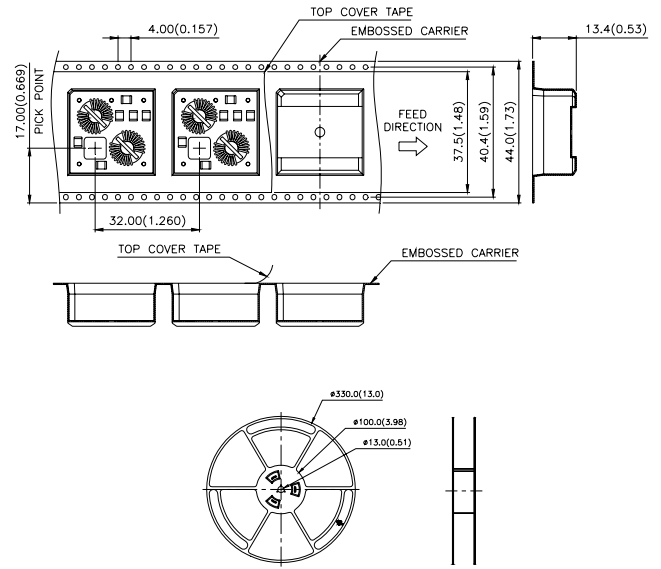

## RECOMMENDED PAD PATTERN (SMD)

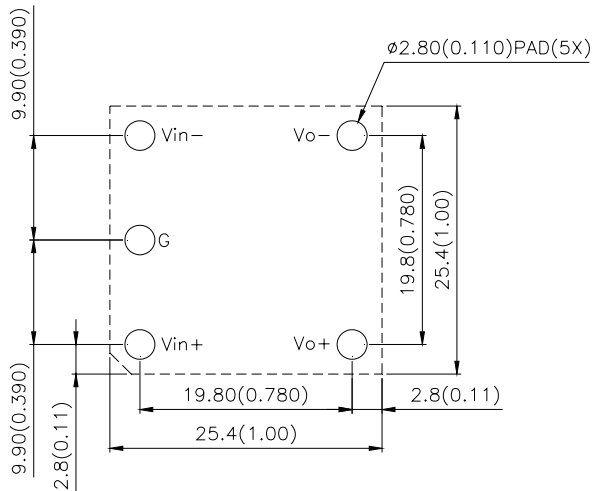

Note: Inside this filter module, the components have no voltage polarity. Hence, the input positive (Vin+) and input negative (Vin-) labels could be swapped for the convenience of layout and matching with power module input connected to the filter module, just remember to swap the output labels accordingly as well. Please refer to Figures 8 and 10 for how it is applied.



## LEADED (Sn/Pb) PROCESS RECOMMEND TEMP. PROFILE

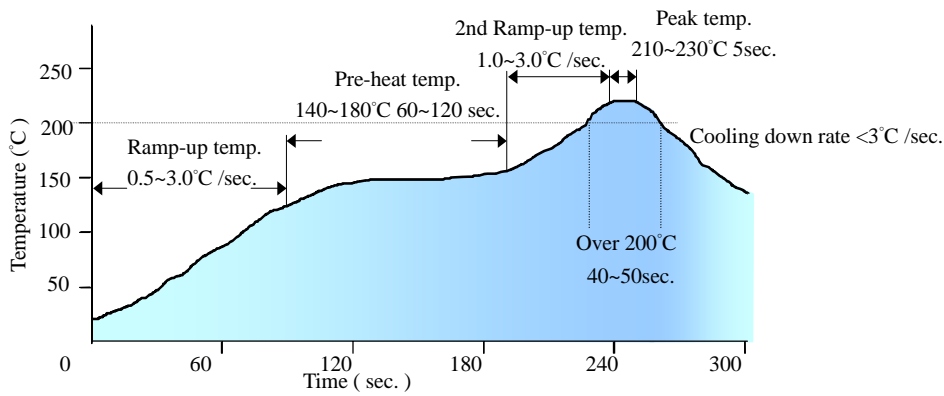

*Note: The temperature refers to the pin of filter 7A, measured on the pin 1 (+Vout) joint.*

## LEAD FREE (SAC) PROCESS RECOMMEND TEMP. PROFILE

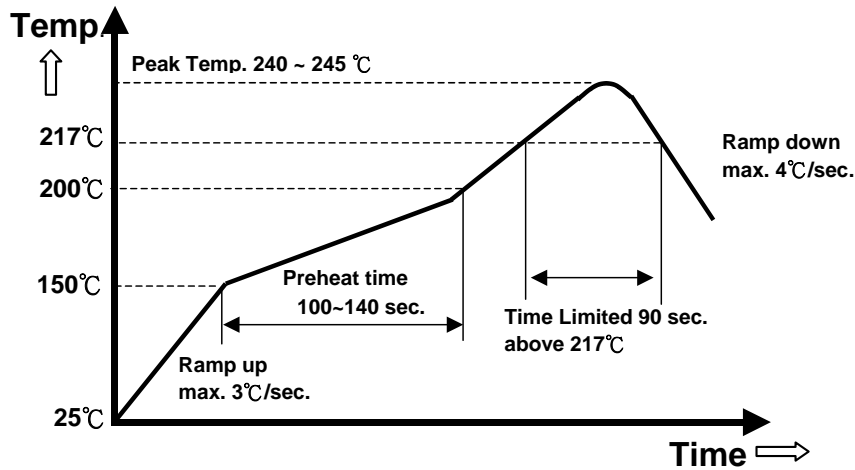

*Note: The temperature refers to the pin of filter 7A, measured on the pin 1 (+Vout) joint.*

## PART NUMBERING SYSTEM

<b>FL</b>	<b>75</b>	<b>L</b>	<b>07</b>		<b>A</b>
<b>Product Family</b>	<b>Input Voltage</b>	<b>Product Series</b>	<b>Output Current</b>		<b>Option Code</b>
FL- Filter	0 ~ 75V	L – standard	7A		A - Standard, SMD pins (7A only)

## MODEL LIST

<b>Module Name</b>	<b>Input Voltage (max.)</b>	<b>Current Rating (max.)</b>	<b>Size (metric)</b>	<b>Size (English unit)</b>
FL75L05 A	75V	5A	25.4 x 25.4 x 10.2 mm	1.0 in. x 1.0 in. x 0.4 in.
FL75L07 A	75V	7A	25.4 x 25.4 x 12.0 mm	1.0 in. x 1.0 in. x 0.47 in.
FL75L10 A	75V	10A	50.8 x 27.9 x 12.5 mm	2.0 in. x 1.1 in. x 0.5 in.
FL75L20 A	75V	20A	50.8 x 40.6 x 12.7 mm	2.0 in. x 1.6 in. x 0.5 in.

**CONTACT:** [www.delta.com.tw/dcdc](http://www.delta.com.tw/dcdc)

### USA:

Telephone:  
East Coast: (888) 335 8201  
West Coast: (888) 335 8208  
Fax: (978) 656 3964  
Email: [DCDC@delta-corp.com](mailto:DCDC@delta-corp.com)

### Europe:

Telephone: +41 31 998 53 11  
Fax: +41 31 998 53 53  
Email: [DCDC@delta-es.tw](mailto:DCDC@delta-es.tw)

### Asia & the rest of world:

Telephone: +886 3 4526107 ext 6220  
Fax: +886 3 4513485  
Email: [DCDC@delta.com.tw](mailto:DCDC@delta.com.tw)

## WARRANTY

Delta offers a two (2) year limited warranty. Complete warranty information is listed on our web site or is available upon request from Delta.

Information furnished by Delta is believed to be accurate and reliable. However, no responsibility is assumed by Delta for its use, nor for any infringements of patents or other rights of third parties, which may result from its use. No license is granted by implication or otherwise under any patent or patent rights of Delta. Delta reserves the right to revise these specifications at any time, without notice.