

**4-CHANNEL MOTOR DRIVER FOR DVD PLAYER****AM5954A****General Description**

The AM5954A is a four-channel BTL driver IC for driving the motors and actuators in products for DVD-player drivers. Two of the channels use current feedback to minimize the current phase shift caused by the influence of load inductance. This IC is an improved version of AZ5954.

The AM5954A is available in HSOP-28 Package.

Features

- Level Shift Circuit On Chip
- Internal Standby Mode
- Built-in Thermal Shutdown Circuit

Applications

- DVD Player



Figure 1. Package Type of AM5954A



4-CHANNEL MOTOR DRIVER FOR DVD PLAYER

AM5954A

Pin Configuration

M28 Package
(HSOP-28)

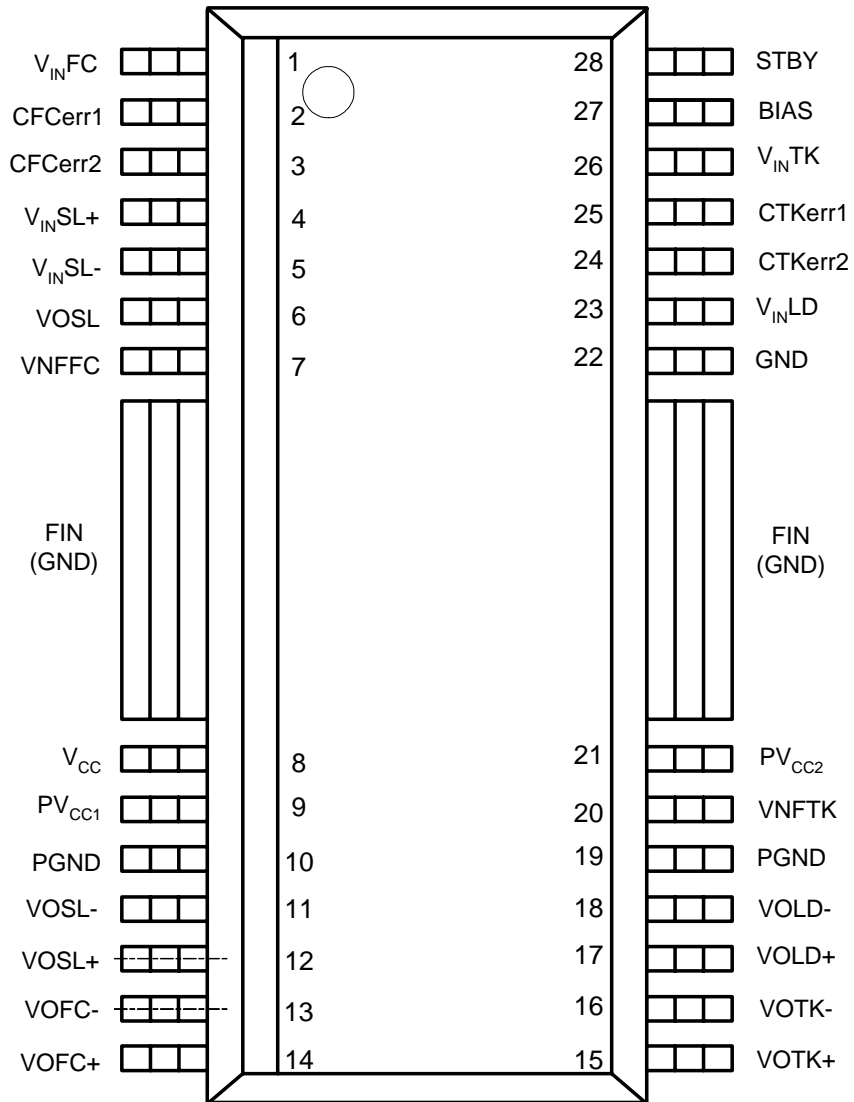

Figure 2. Pin Configuration of AM5954A (Top View)

**4-CHANNEL MOTOR DRIVER FOR DVD PLAYER****AM5954A****Pin Description (Note 1)**

Pin Number	Pin Name	Function
1	V _{INFC}	Focus driver input
2	CFCerr1	For connection of capacitor for the error amp filter
3	CFCerr2	For connection of capacitor for the error amp filter
4	V _{INSL+}	Op Amp input (+) for the sled driver
5	V _{INSL-}	Op Amp input (-) for the sled driver
6	VOSL	Op Amp output for the sled driver
7	VNFFC	Focus driver feedback pin
8	V _{CC}	Supply voltage
9	PV _{CC1}	Power supply for loading channel
10	PGND	Ground for sled driver block
11	VOSL-	Sled driver output (-)
12	VOSL+	Sled driver output (+)
13	VOFC-	Focus driver output (-)
14	VOFC+	Focus driver output (+)
15	VOTK+	Tracking driver output (+)
16	VOTK-	Tracking driver output (-)
17	VOLD+	Loading driver output (+)
18	VOLD-	Loading driver output (-)
19	PGND	Ground for actuator driver block
20	VNFTK	Tracking driver feedback pin
21	PV _{CC2}	Power supply voltage for actuator driver block
22	GND	Ground
23	V _{INLD}	Loading driver input
24	CTKerr2	For connection of capacitor for the error amp filter
25	CTKerr1	For connection of capacitor for the error amp filter
26	V _{INTK}	Tracking driver input
27	BIAS	Bias input
28	STBY	Standby control

Note 1: The indicated polarities for the output pin are for when all inputs are (+).

The output H bridge power supply pins are PV_{CC2} for the focus, tracking channel, PV_{CC1} for the loading channel, and V_{CC} for the pre-block and sled channel.

Always ensure that $V_{CC} \geq PV_{CC}$.



4-CHANNEL MOTOR DRIVER FOR DVD PLAYER

AM5954A

Functional Block Diagram

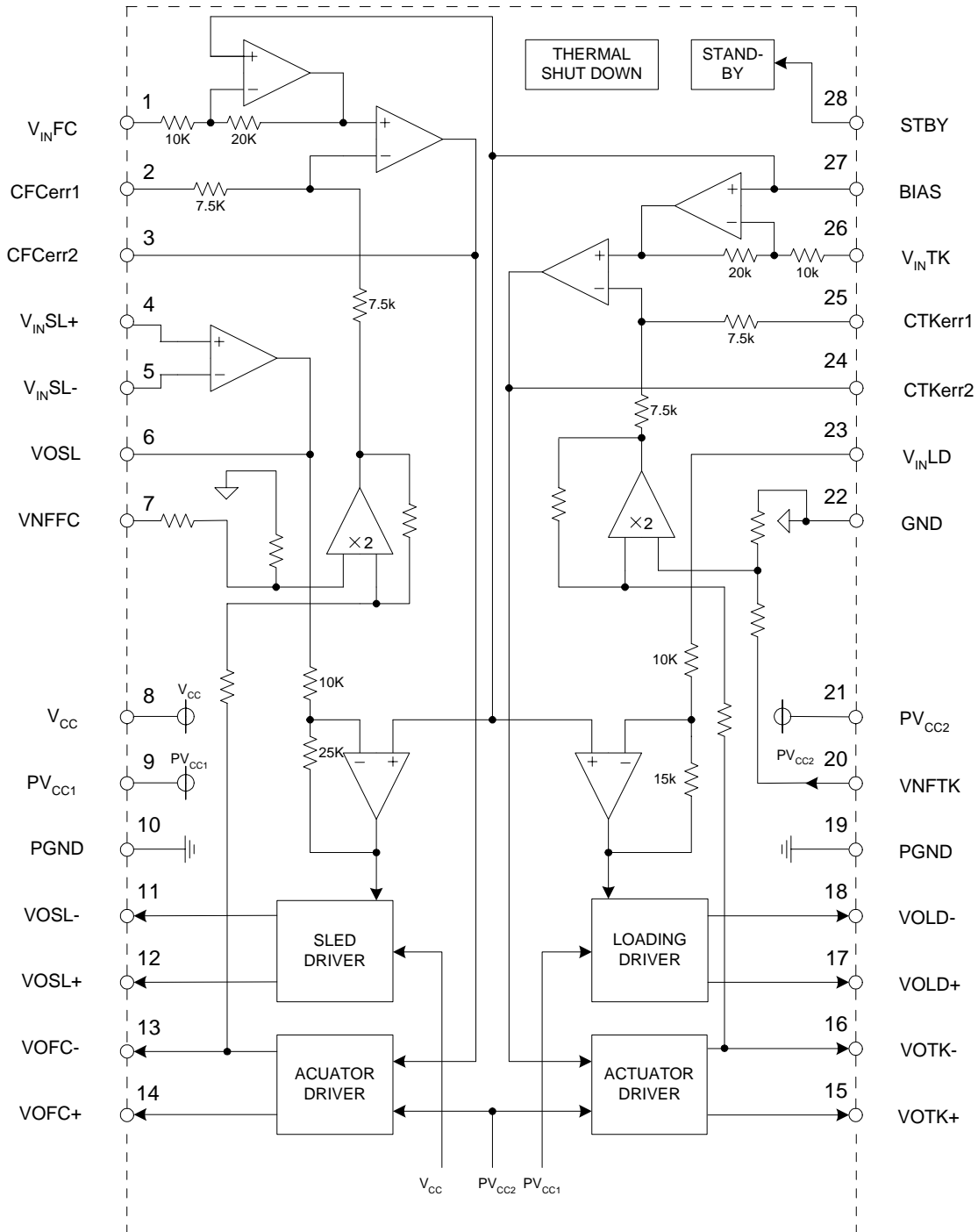

Figure 3. Functional Block Diagram of AM5954A



4-CHANNEL MOTOR DRIVER FOR DVD PLAYER

AM5954A

Ordering Information

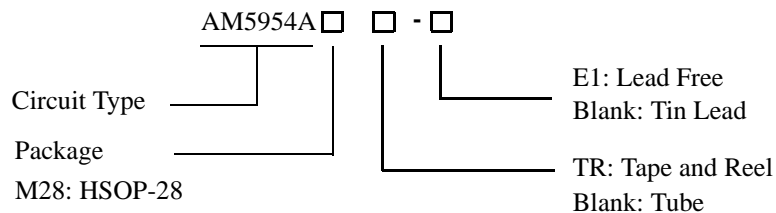

Package	Temperature Range	Part Number		Marking ID		Packing Type
		Tin Lead	Lead Free	Tin Lead	Lead Free	
HSOP-28	0 to 70°C	AM5954AM28	AM5954AM28-E1	AM5954AM28	AM5954AM28-E1	Tube
			AM5954AM28TR-E1		AM5954AM28-E1	Tape & Reel

BCD Semiconductor's Pb-free products, as designated with "E1" suffix in the part number, are RoHS compliant.

Absolute Maximum Ratings (Note 2)

Parameter	Symbol	Value	Unit
Supply Voltage	$V_{CC}, PV_{CC1/2}$	13.5	V
Power Dissipation	P_D	1.7 (Note 3)	W
Operating Junction Temperature	T_J	150	°C
Storage Temperature Range	T_{STG}	-55 to 150	°C
ESD (Human Body Model)	ESD	2000	V
ESD (Machine Model)	ESD	200	V

Note 2: Stresses greater than those listed under "Absolute Maximum Ratings" may cause permanent damage to the device. These are stress ratings only, and functional operation of the device at these or any other conditions beyond those indicated under "Recommended Operating Conditions" is not implied. Exposure to "Absolute Maximum Ratings" for extended periods may affect device reliability.

Note 3: The power dissipation is reduced by 13.6mW for each increase in temperature of 1°C over 25°C.

Recommended Operating Conditions

Parameter	Symbol	Min	Max	Unit
Supply Voltage	V_{CC}	4.0	13.2	V
	PV_{CC1}	4.0	V_{CC}	V
	PV_{CC2}	4.0	V_{CC}	V
Operating Temperature	T_A	0	70	°C



4-CHANNEL MOTOR DRIVER FOR DVD PLAYER

AM5954A

Electrical Characteristics

($T_A=25^{\circ}C$, $V_{CC}=PV_{CC}=12V$, $PV_{CC2}=5V$, $V_{BIAS}=2.5V$, $R_{L1}=R_{L2}=R_{L3}=R_{L4}=8\Omega$, $R_D=0.5\Omega$, $C_{FC}=C_{TK}=100pF$, unless otherwise specified.)

Parameter	Symbol	Test Conditions	Min	Typ	Max	Unit
Quiescent Current	I_{QC}			18	27	mA
Standby Current	I_{ST}				0.5	mA
Standby-on Voltage	V_{STON}	All channels off	0		0.5	V
Standby-off Voltage	V_{STOFF}	All channels on	2.0			V
Actuator Driver						
Output Offset Current	I_{OO}		-6		6	mA
Maximum Output Amplitude	V_{OM}	$V_{IN}=V_{BIAS}\pm 1.5V$	3.6	3.8		V
Transmission Gain	gm	$V_{IN}=V_{BIAS}\pm 0.2V$	1.3	1.5	1.7	A/V
Sled Motor Driver/Pre Op Amp						
Common Input Voltage Range	V_{ICM}	$V_{BIAS}=6V$	-0.3		11.0	V
		$V_{CC}=PV_{CC1}=5V$	-0.3		4.0	V
Input Bias Current	I_{IB}			14	300	nA
Output Low Level Voltage	V_{OL}			0.1	0.3	V
Output Source Current	I_{SO}		0.3	0.58		mA
Output Sink Current	I_{SI}		1			mA
Sled Motor Driver						
Output Offset Voltage	V_{OOFSL}	$V_{CC}=5V$	-100		100	mV
Maximum Output Voltage	V_{OMSL}	$V_{IN}=V_{BIAS}\pm 1.5V$	7.5	9		V
Closed-loop Voltage Gain	G_{VSL}	$V_{IN}=V_{BIAS}\pm 0.2V$	18.0	20.0	22.0	dB
Loading Motor Driver						
Output Offset Voltage	V_{OOFLD}		-50		50	mV
Maximum Output Voltage	V_{OMLD}	$V_{IN}=V_{BIAS}\pm 2.0V$	7.5	9		V
		$V_{IN}=V_{BIAS}\pm 1.5V$ $V_{CC}=PV_{CC1}=5V$	3.6	3.8		V
Closed-loop Voltage Gain	G_{VLD}	$V_{IN}=V_{BIAS}\pm 0.2V$	13.5	15.5	17.5	dB
Gain Error by Polarity	ΔG_{VLD}	$V_{IN}=V_{BIAS}\pm 0.2V$	0	1	2	dB



4-CHANNEL MOTOR DRIVER FOR DVD PLAYER

AM5954A

Test Circuit

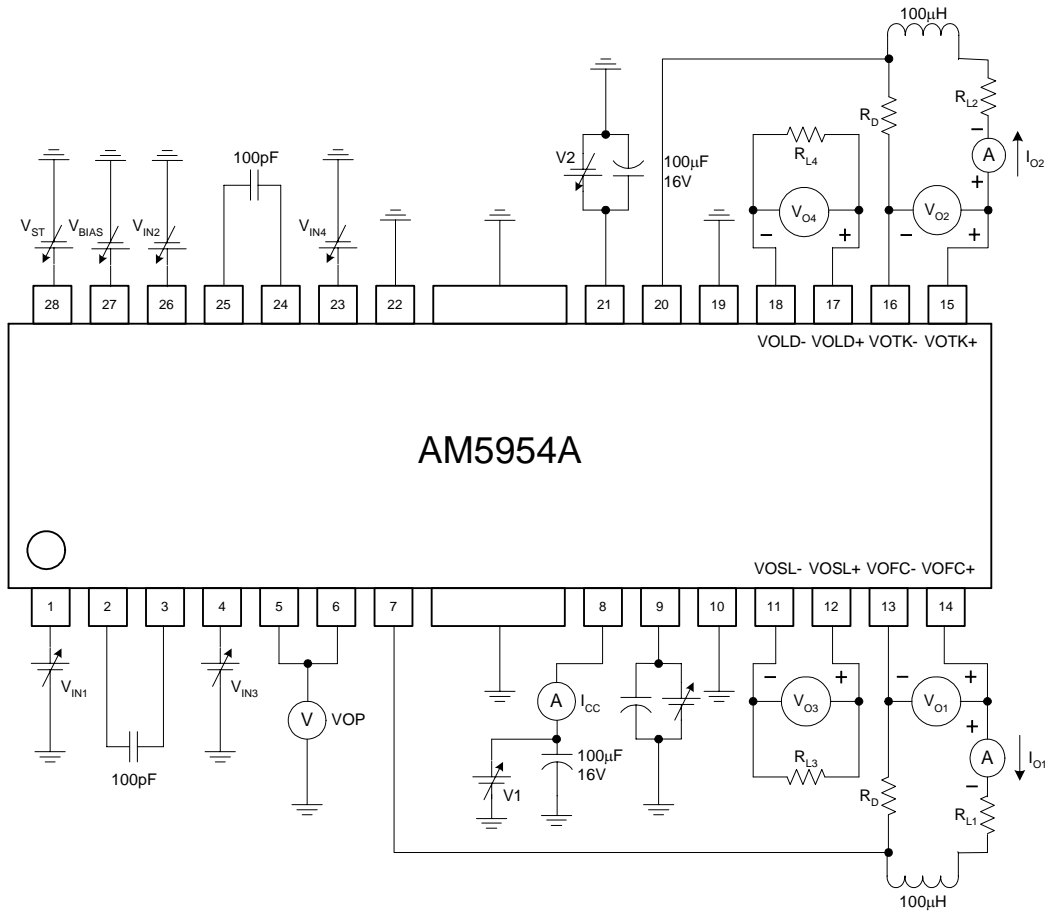

Figure 4. Test Circuit of AM5954A



4-CHANNEL MOTOR DRIVER FOR DVD PLAYER

AM5954A

Typical Performance Characteristics

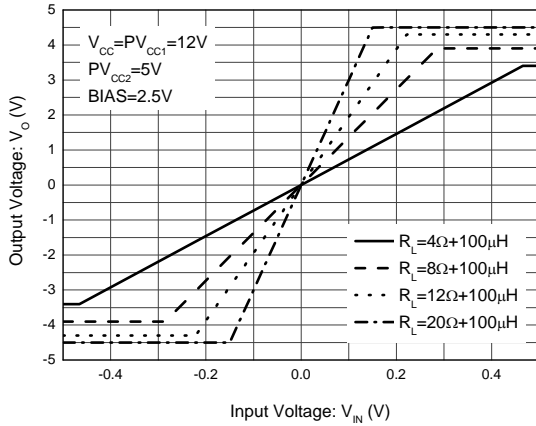

Figure 5. Driver I/O Characteristics (Focus and Tracking, Note 4)

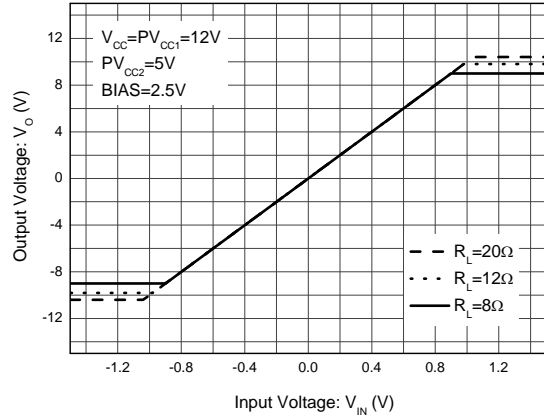

Figure 6. Driver I/O Characteristics (Sled, Note 4)

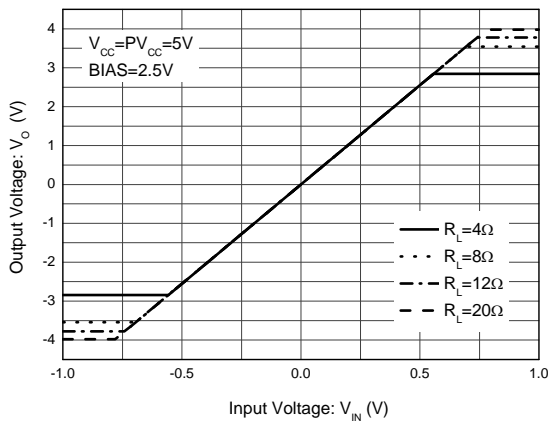

Figure 7. Driver I/O Characteristics (Loading, Note 4)

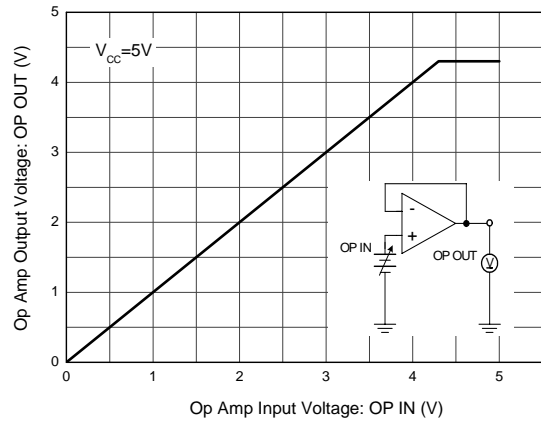

Figure 8. Op Amp I/O Characteristics (Note 4)

Note 4: Input voltage herein is referenced to Bias pin voltage.



4-CHANNEL MOTOR DRIVER FOR DVD PLAYER

AM5954A

Typical Performance Characteristics (Continued)

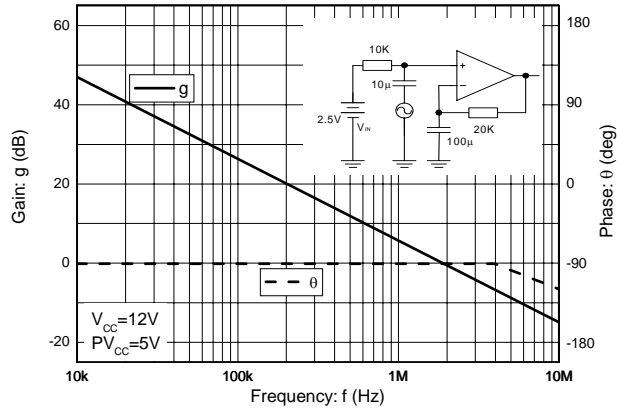

Figure 9. Op Amp Phase-Frequency, Amplitude-Frequency Characteristics

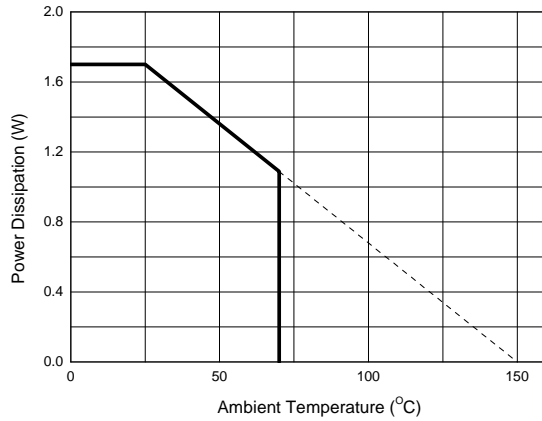

Figure 10. Power Dissipation Curve



4-CHANNEL MOTOR DRIVER FOR DVD PLAYER **AM5954A**

Typical Application

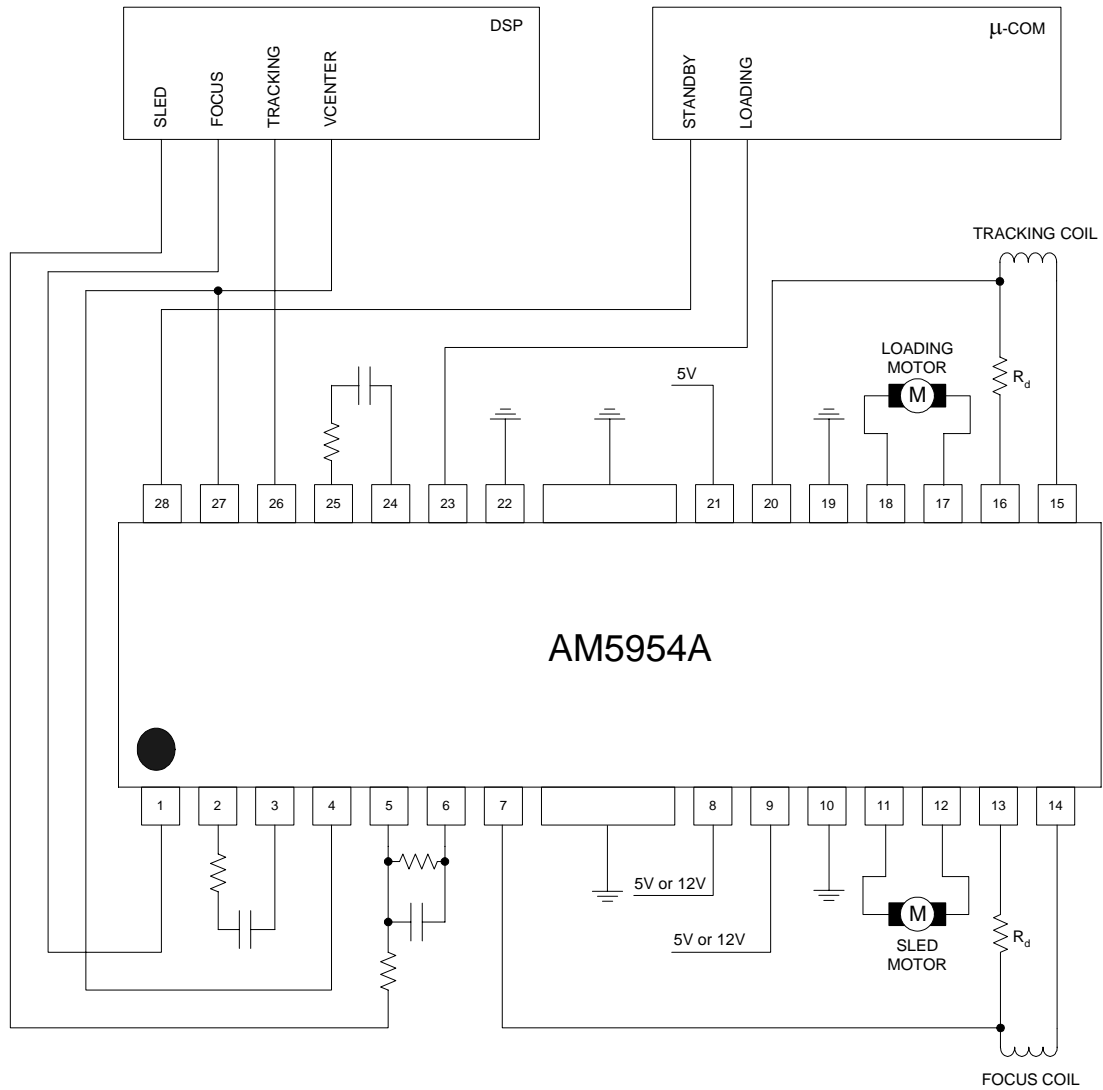

Figure 11. Typical Application of AM5954A in DVD Player

**4-CHANNEL MOTOR DRIVER FOR DVD PLAYER****AM5954A****Application Information**

1. This IC has a built-in thermal shutdown circuit that mutes the output current when the chip temperature reaches 178°C (Typ). The hysteresis is set to 25°C (Typ), so the driver circuits start up again when the chip temperature falls to 153°C (Typ).
2. The driver buffer is switched off when the supply voltage falls below 3.5V (Typ), and is switched back on when the voltage reaches 3.7V (Typ) again.
3. In case standby pin voltage is under 0.5V or opened, quiescent current is muted. Standby pin voltage should be over 2.0V for normal application.
4. BIAS pin (pin 27) should be pulled up more than 1.2V. In case bias pin voltage is pulled down under 0.9V (Typ), output current is muted.
5. Insert the by-pass capacitor (approximately 0.1μF) between V_{CC}-pin and GND-pin as near as possible to this IC.
6. Heat dissipation fins are attached to the GND inside the package. Make sure to connect them to the external GND.

Supplement: (Current-feedback driver)

The transmission gain (output current/input voltage) is given by:

$$gm=1/(R_D + R_{WIRE}) (A/V)$$

R_{WIRE} is the total gold wire resistance inside the package (0.15Ω ± 0.05Ω) (Typ).



4-CHANNEL MOTOR DRIVER FOR DVD PLAYER

AM5954A

Mechanical Dimensions

HSOP-28

Unit: mm(inch)

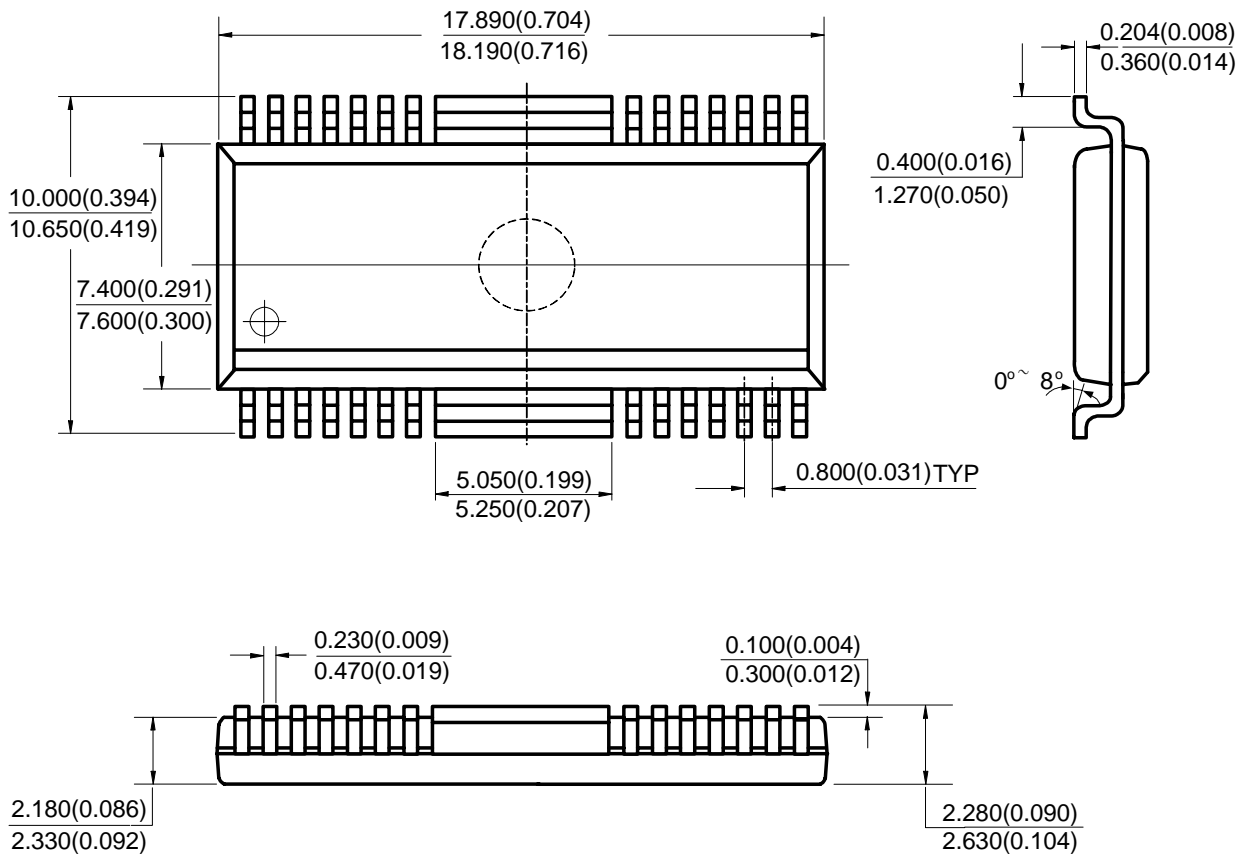



BCD Semiconductor Manufacturing Limited

<http://www.bcdsemi.com>

IMPORTANT NOTICE

BCD Semiconductor Manufacturing Limited reserves the right to make changes without further notice to any products or specifications herein. BCD Semiconductor Manufacturing Limited does not assume any responsibility for use of any its products for any particular purpose, nor does BCD Semiconductor Manufacturing Limited assume any liability arising out of the application or use of any its products or circuits. BCD Semiconductor Manufacturing Limited does not convey any license under its patent rights or other rights nor the rights of others.

MAIN SITE

BCD Semiconductor Manufacturing Limited
- Wafer Fab
Shanghai SIM-BCD Semiconductor Manufacturing Limited
800, Yi Shan Road, Shanghai 200233, China
Tel: +86-21-6485 1491, Fax: +86-21-5450 0008

BCD Semiconductor Manufacturing Limited
- IC Design Group
Advanced Analog Circuits (Shanghai) Corporation
8F, Zone B, 900, Yi Shan Road, Shanghai 200233, China
Tel: +86-21-6495 9539, Fax: +86-21-6485 9673

REGIONAL SALES OFFICE

Shenzhen Office
Shanghai SIM-BCD Semiconductor Manufacturing Co., Ltd. Shenzhen Office
Advanced Analog Circuits (Shanghai) Corporation Shenzhen Office
Room E, 5F, Noble Center, No.1006, 3rd Fuzhong Road, Futian District, Shenzhen 518026, China
Tel: +86-755-8826 7951
Fax: +86-755-8826 7865

Taiwan Office
BCD Semiconductor (Taiwan) Company Limited
4F, 298-1, Rui Guang Road, Nei-Hu District, Taipei,
Taiwan
Tel: +886-2-2656 2808
Fax: +886-2-2656 2806

USA Office
BCD Semiconductor Corporation
30920 Huntwood Ave. Hayward,
CA 94544, U.S.A
Tel : +1-510-324-2988
Fax: +1-510-324-2788