

NOTES:

1.0 PINS NOT ELECTRICALLY CONNECTED ARE OMITTED.

ELECTRICAL SPECIFICATIONS:

1.0 INDUCTANCE: P1-J1=P2-J2 ; P4-J4=P5-J5 : 65 uH 0.01V, 10 KHz, nominal.

2.0 DC RESISTANCE: P1-J1 : .5 ohm MAX  
 P2-J2 : .5 ohm MAX  
 P4-J4 : .5 ohm MAX  
 P5-J5 : .5 ohm MAX

3.0 COMMON MODE:

FREQUENCY (MHz)	CMA (-dB)	
	TYPICAL	MIN
1	8	5
5	17	15
20	23	15
70	25	20
200	22	17
500	11	6

Bel Stewart Connector  
 11118 Susquehanna Trail, South  
 Glen Rock, Pa 17327-9199  
 717.234.7512

**MagJack®**

<http://www.stewartconnector.com>

SHEET  
1 OF 3

DRAWING NO. SI-60043 REV. 13

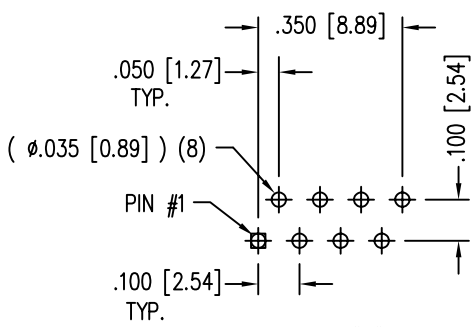
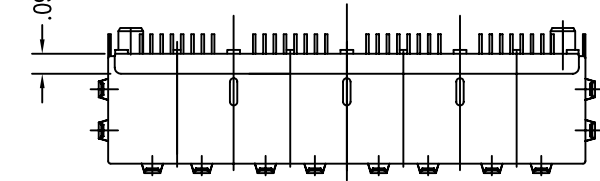
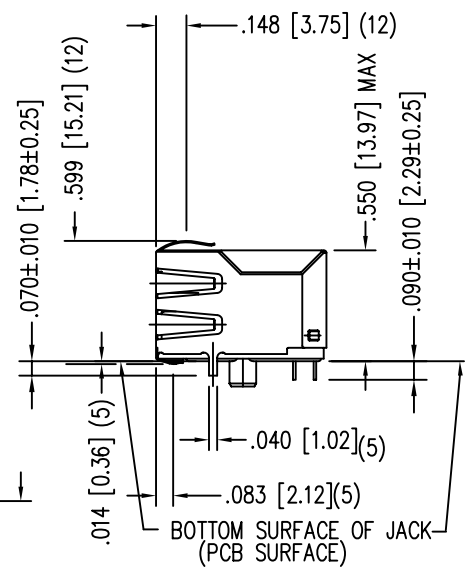
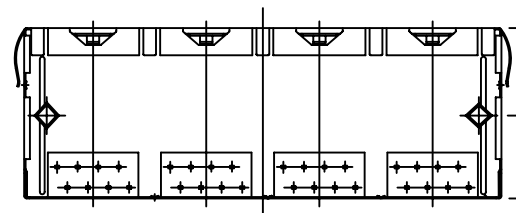
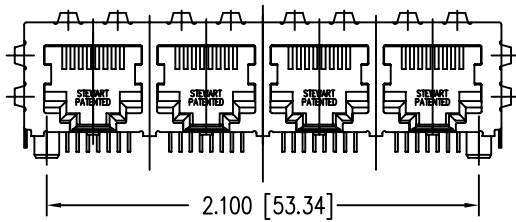
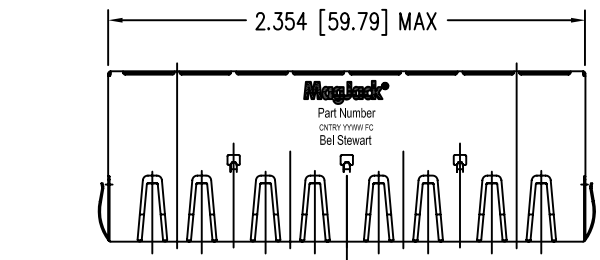

DETAIL "A"  
TYPICAL HOLE LAYOUT

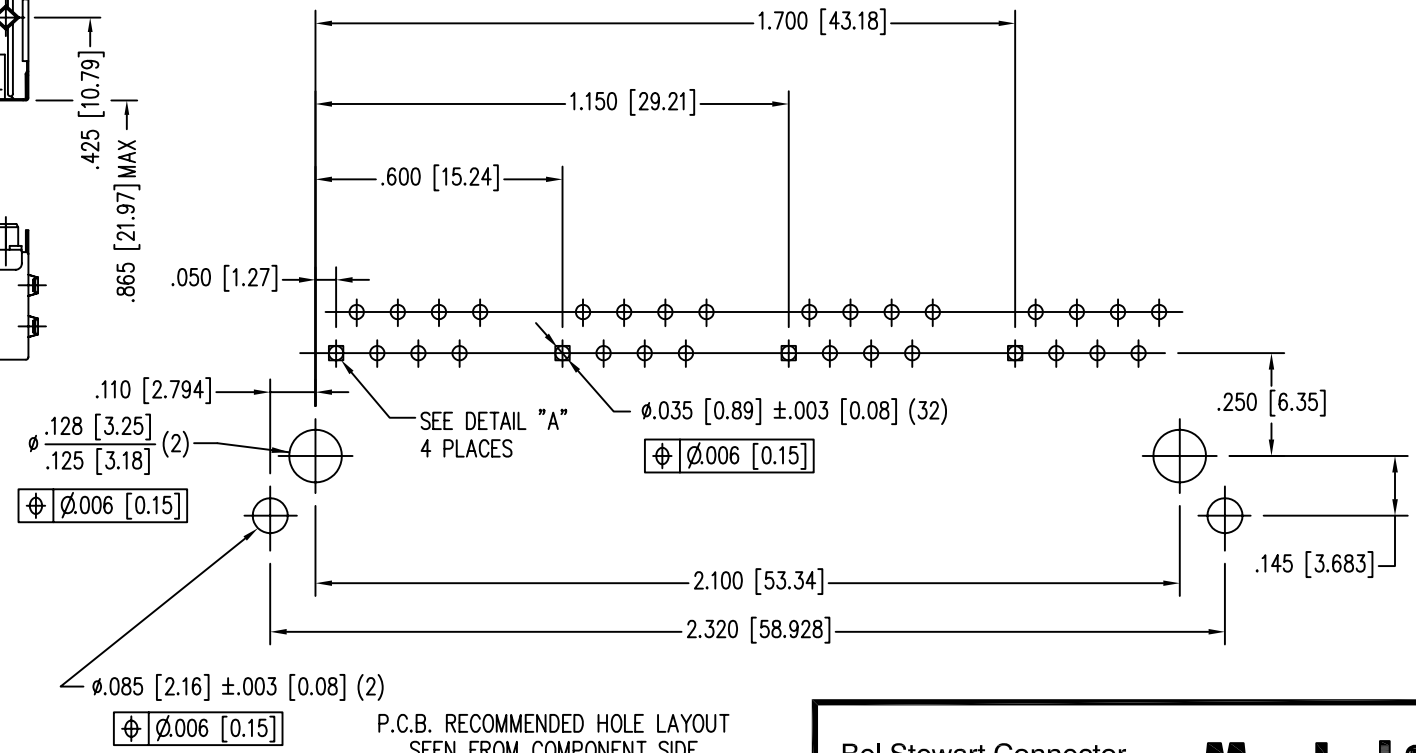

P.C.B. RECOMMENDED HOLE LAYOUT  
SEEN FROM COMPONENT SIDE

ALL CENTERLINE DIMENSIONS ARE BASIC.

NOTES:

- CONNECTOR MATERIALS:  
HOUSING: THERMOPLASTIC UL94 V-0  
CONTACT/SHIELD: COPPER ALLOY  
SHIELD PLATING: NICKEL OR TIN  
CONTACT PLATING: SELECTIVE GOLD,  
50 MICRO-INCHES MIN. IN CONTACT AREA.
- PIN NOT ELECTRICALLY CONNECTED MAYBE OMITTED.  
SEE ELECTRICAL DRAWING FOR OMITTED PINS.
- TOLERANCES COMPLY WITH F.C.C. DIMENSION REQUIREMENTS.
- ALL TOLERANCES NOT OTHERWISE SPECIFIED TO BE ±.005 [0.13]
- WAVE SOLDER COMPATIBLE - PREHEAT 125°C/90SECS.  
HIGH TEMPERATURE REFLOW COMPATIBLE - 230°C/90 SEC MAX.
- ALL LEDS AND SOLDER TAILS TO BE TRIMED TO .090 [2.29]
- REAR SHIELD SOLDER TAILS TO BE TRIMED FLUSH AND  
SIDE TAILS TO BE TRIMED TO .070 [1.78]

Bel Stewart Connector  
11118 Susquehanna Trail, South  
Glen Rock, Pa 17327-9199  
717.234.7512

**MagJack**<sup>®</sup>

<http://www.stewartconnector.com>

THIS DRAWING AND THE SUBJECT MATTER SHOWN THEREON ARE CONFIDENTIAL AND PROPERTY OF BEL STEWART CONNECTOR AND SHALL NOT BE REPRODUCED, COPIED, OR USED IN ANY MANNER WITHOUT PRIOR WRITTEN CONTENT OF BEL STEWART CONNECTOR. THE SUBJECT MATTER MAY BE PATENTED OR A PATENT MAY BE PENDING.

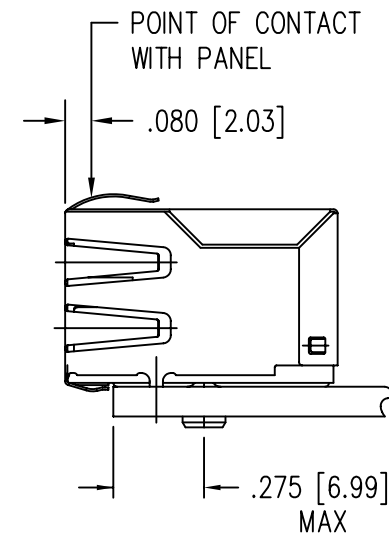
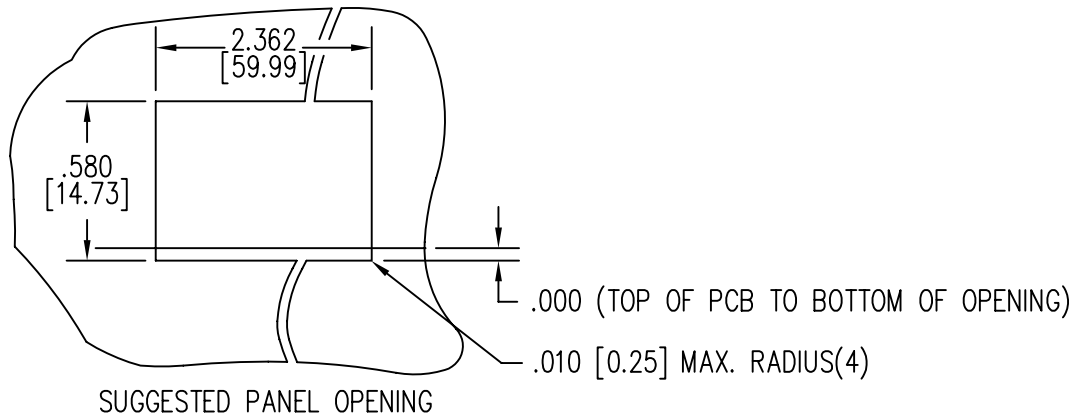

1. THE SUGGESTED PANEL OPENING IS INTENDED TO GIVE THE USER THE ABILITY TO HAVE REASONABLE JACK / PANEL CLEARANCES YET MAINTAIN RELIABLE GROUNDING CAPABILITY.
2. ALL TOLERANCES NOT OTHERWISE SPECIFIED TO BE  $\pm 0.005$  [0.13]

Bel Stewart Connector  
 11118 Susquehanna Trail, South  
 Glen Rock, Pa 17327-9199  
 717.234.7512

**MagJack®**

<http://www.stewartconnector.com>

THIS DRAWING AND THE SUBJECT MATTER SHOWN THEREON ARE CONFIDENTIAL AND PROPERTY OF BEL STEWART CONNECTOR AND SHALL NOT BE REPRODUCED, COPIED, OR USED IN ANY MANNER WITHOUT PRIOR WRITTEN CONTENT OF BEL STEWART CONNECTOR. THE SUBJECT MATTER MAY BE PATENTED OR A PATENT MAY BE PENDING.

SHEET  
3 OF 3

DRAWING NO. SI-60043

REV. 04