

ELECTRICAL SPECIFICATIONS:

- 1.0 TURNS RATIO: (P7-P6-P8) : (J3-J6) : 1CT : 1CT ± 3%  
(P1-P3-P2) : (J1-J2) : 1CT : 1CT ± 3%
- 2.0 INDUCTANCE: (P7-P8) : 350uH MIN. @ 0.1V, 100KHz, 8mA DC Bias  
(P1-P2) : 350uH MIN. @ 0.1V, 100KHz, 8mA DC Bias
- 3.0 LEAKAGE INDUCTANCE: P8-P6-P7 (WITH J6 AND J3 SHORT) : 0.3uH MAX. @ 1MHz  
P2-P3-P1 (WITH J2 AND J1 SHORT) : 0.3uH MAX. @ 1MHz
- 4.0 INTERWINDING CAPACITANCE: (P8,P6,P7) TO (J6,J3) : 30pf MAX @ 1MHz  
(P2,P3,P1) TO (J2,J1) : 30pf MAX @ 1MHz
- 5.0 DC RESISTANCE: (P7-P8)=(J2-J1) : 1.2 ohms Max.

NOTES

1.0 PINS WITHOUT ELECTRICAL CONNECTION ARE OMITTED.

Bel Stewart Connector  
11118 Susquehanna Trail, South  
Glen Rock, Pa 17327-9199  
717.234.7512

**MagJack®**

<http://www.stewartconnector.com>

THIS DRAWING AND THE SUBJECT MATTER SHOWN THEREON ARE CONFIDENTIAL AND PROPERTY OF BEL STEWART CONNECTOR AND SHALL NOT BE REPRODUCED, COPIED, OR USED IN ANY MANNER WITHOUT PRIOR WRITTEN CONTENT OF BEL STEWART CONNECTOR. THE SUBJECT MATTER MAY BE PATENTED OR A PATENT MAY BE PENDING.

SHEET 1 OF 3

DRAWING NO. SI-50083 REV. 05

RECEIVE

6.0 RETURN LOSS: (J3-J6)=100 OHMS AND (P1-P2)=100 OHM REF.  
1MHz TO 30MHz : -18dB MIN.  
30MHz TO 60MHz : -(19-20 LOG (f/30MHz))  
60MHz TO 80MHz : -12dB MIN.

NOTE: 100 OHMS CONNECTED TO (J2-J1) OR (P7-P8).

7.0 DIELECTRIC WITHSTAND: (J1, J2) TO (P7, P8) : 1500 VAC  
(J3, J6) TO (P1,P2) : 1500 VAC

8.0 INSERTION LOSS: RS=RL=100 ohms : -1.0 dB MAX  
1-65MHz

9.0 RISE TIME: RS=100 OHMS AND RL = 100 OHMS : 3.0 nS MAX  
OUTPUT VOLTAGE = 1 V peak : 3.0 nS MAX  
PULSE WIDTH= 112nS

10.0 CROSS TALK: 1-65MHz : -35 dB MIN

11.0 COMMON TO COMMON MODE ATTENUATION: 30MHz TO 100MHz : -30dB MAX  
100MHz TO 130MHz : -20dB MAX

Bel Stewart Connector  
11118 Susquehanna Trail, South  
Glen Rock, Pa 17327-9199  
717.234.7512

**MagJack**<sup>®</sup>

<http://www.stewartconnector.com>

THIS DRAWING AND THE SUBJECT MATTER SHOWN THEREON ARE CONFIDENTIAL AND PROPERTY OF BEL STEWART CONNECTOR AND SHALL NOT BE REPRODUCED, COPIED, OR USED IN ANY MANNER WITHOUT PRIOR WRITTEN CONTENT OF BEL STEWART CONNECTOR. THE SUBJECT MATTER MAY BE PATENTED OR A PATENT MAY BE PENDING.

SHEET  
2 OF 3

DRAWING NO. SI-50083

REV. 05

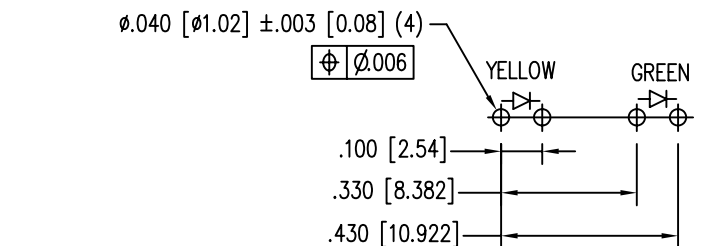

DETAIL "B"  
TYPICAL LED HOLE LAYOUT

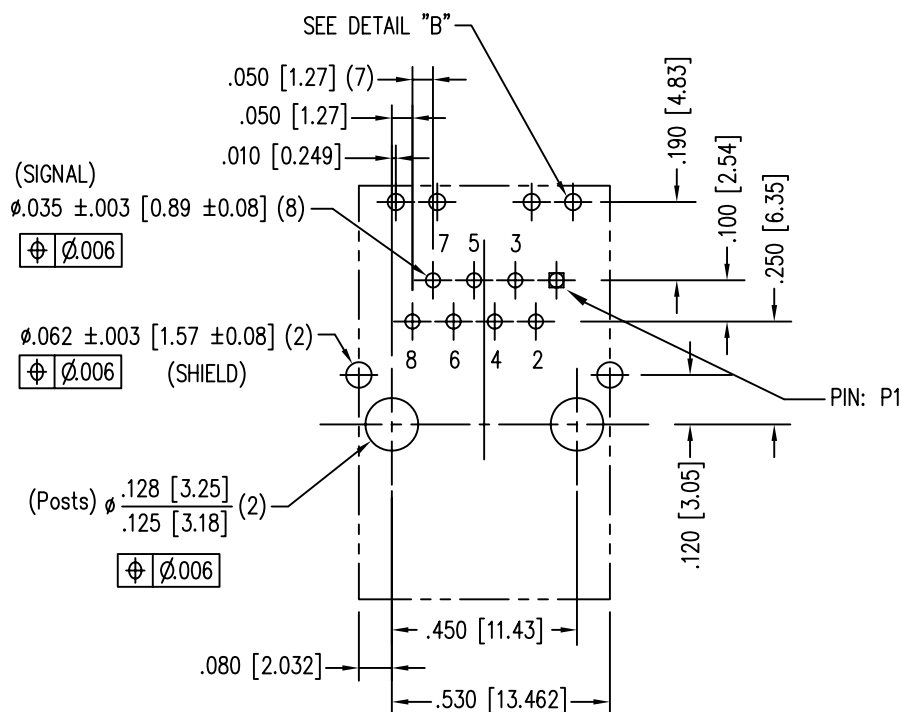
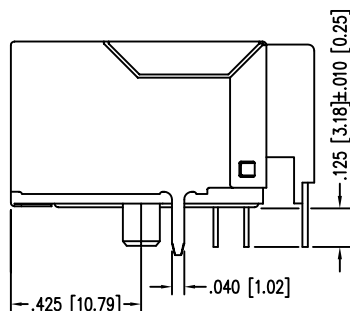
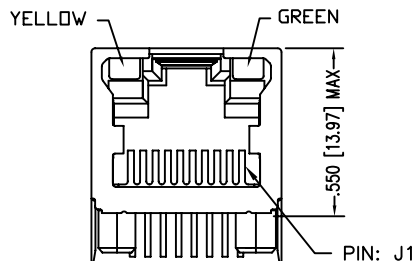

P.C.B. RECOMMENDED HOLE LAYOUT  
SEEN FROM COMPONENT SIDE

ALL CENTERLINE DIMENSIONS ARE BASIC.

NOTES:

- CONNECTOR MATERIALS:  
HOUSING: THERMOPLASTIC UL94 V-0  
CONTACT/SHIELD: COPPER ALLOY  
SHIELD PLATING: NICKEL OR TIN  
CONTACT PLATING: SELECTIVE GOLD,  
50 MICRO-INCHES MIN. IN CONTACT AREA.
- PIN NOT ELECTRICALLY CONNECTED MAYBE OMITTED.  
SEE ELECTRICAL DRAWING FOR OMITTED PINS.
- TOLERANCES COMPLY WITH F.C.C. DIMENSION REQUIREMENTS.
- ALL TOLERANCES NOT OTHERWISE SPECIFIED TO BE ±0.005 [0.13]
- WAVE SOLDER COMPATIBLE - PREHEAT 125°C/90SECS.

LED SPECIFICATION			
STANDARD LED	WAVELENGTH	FORWARD V (MAX)	*(TYP)
GREEN	565 nm	2.5 V	2.2 V
YELLOW	590 nm	2.5 V	2.1 V

\*WITH A FORWARD CURRENT OF 20 mA (TYP)

Bel Stewart Connector  
11118 Susquehanna Trail, South  
Glen Rock, Pa 17327-9199  
717.234.7512

**MagJack**

<http://www.stewartconnector.com>

THIS DRAWING AND THE SUBJECT MATTER SHOWN THEREON ARE CONFIDENTIAL AND PROPERTY OF BEL STEWART CONNECTOR AND SHALL NOT BE REPRODUCED, COPIED, OR USED IN ANY MANNER WITHOUT PRIOR WRITTEN CONTENT OF BEL STEWART CONNECTOR. THE SUBJECT MATTER MAY BE PATENTED OR A PATENT MAY BE PENDING.

SHEET  
3 OF 3

DRAWING NO.

SI-50083 REV. 07