

ELECTRICAL SPECIFICATIONS:



1.0 TURNS RATIO: (P3-P2) : (J4-J5) : 1 : 1 ±2%
 (P5-P4) : (J6-J3) : 1 : 1 ±2%
 (P9-P8) : (J8-J7) : 1 : 1 ±2%
 (P10-P11) : (J2-J1) : 1 : 1 ±2%

2.0 INDUCTANCE: (P3-P2) ; (P5-P4) : 350 uH MIN. @ 0.1V, 100KHz, 8 mA DC BIAS
 (P10-P11) ; (P9-P8) : 350 uH MIN. @ 0.1V, 100KHz, 8 mA DC BIAS

3.0 LEAKAGE INDUCTANCE: P3-P2 (WITH J4 AND J5 SHORT) : 0.3uH MAX. @ 1MHz
 P5-P4 (WITH J6 AND J3 SHORT) : 0.3uH MAX. @ 1MHz
 P9-P8 (WITH J8 AND J7 SHORT) : 0.3uH MAX. @ 1MHz
 P10-P11 (WITH J1 AND J2 SHORT) : 0.3uH MAX. @ 1MHz

4.0 INTERWINDING CAPACITANCE: (P3-P2) : (J4-J5) : 35pf MAX @ 1MHz
 (P5-P4) : (J6-J3) : 35pf MAX @ 1MHz
 (P9-P8) : (J5-J4) : 35pf MAX @ 1MHz
 (P10-P11) : (J2-J1) : 35pf MAX @ 1MHz

5.0 DC RESISTANCE: (J6-J3) ; (J2-J1) ; (J7-J8) : (J4-J5) : 1.2 ohms Max.

	InNet Technologies, Inc. http://www.innet-tech.com	
		
Stewart Connector Systems http://www.stewartconnector.com		SHEET 1 OF 4
DRAWING NO. SI-41004		REV. X

6.0 RETURN LOSS: 1MHz TO 30MHz	:	-19dB MIN.
30MHz TO 60MHz	:	-13dB MIN.
60MHz TO 80MHz	:	-12dB MIN.
80MHz TO 100MHz	:	-10dB MIN.
7.0 DIELECTRIC WITHSTAND: (J1,J2) TO (P10,P11) ; (J5,J4) TO (P3-P2)	:	1500 VAC
(J3,J6) TO (P5,P4) ; (J8,J7) TO (P9, P8)	:	1500 VAC
8.0 INSERTION LOSS: RS=RL=100 ohms	:	-1.1 dB TYP
100KHz TO 125MHz	:	
9.0 RISE TIME: RS=100 OHMS AND RL = 100 OHMS	:	3.0 nS MAX
OUTPUT VOLTAGE = 1 V peak	:	3.0 nS MAX
PULSE WIDTH= 112nS	:	
10.0 CROSS TALK: 1-100 MHz	:	$-[33-20 \text{ LOG } (\frac{F}{50 \text{ MHz}})] \text{ MIN.}$
11.0 COMMON TO COMMON MODE ATTENUATION: 1MHz TO 100MHz	:	-35dB TYP



InNet Technologies, Inc.
<http://www.innet-tech.com>



Stewart Connector Systems
<http://www.stewartconnector.com>

SHEET
2 OF 4

DRAWING NO.

SI-41004 REV. X

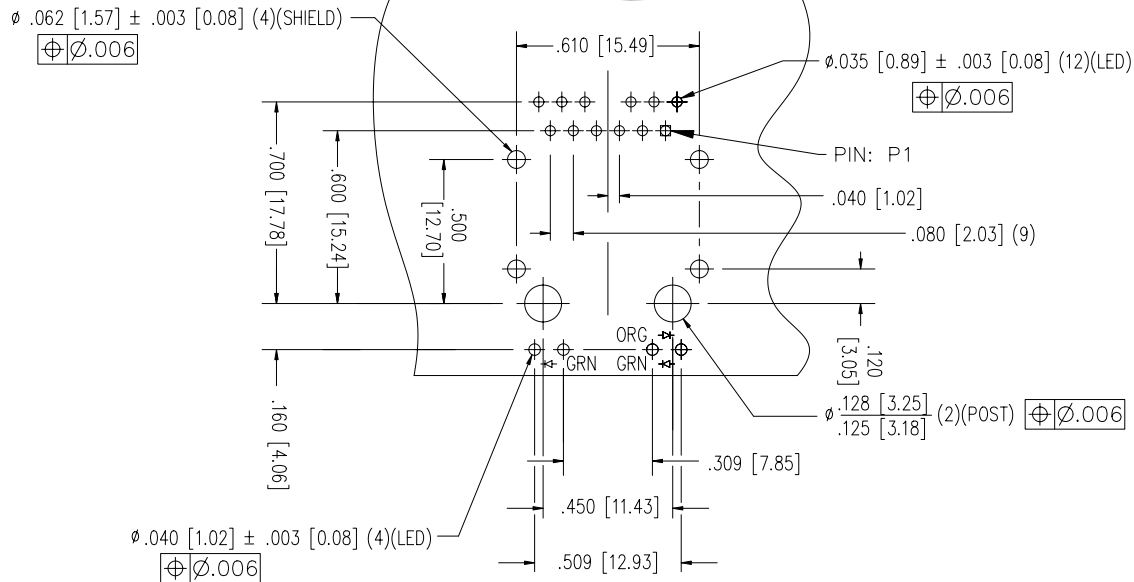
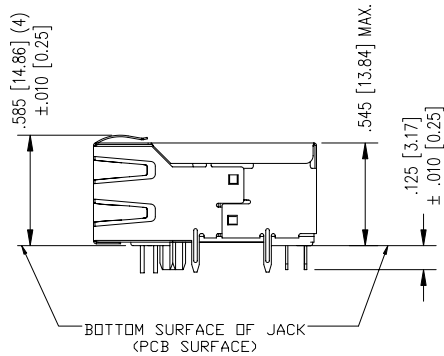
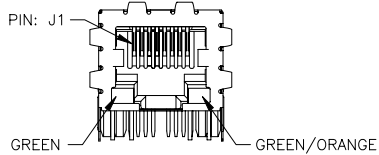
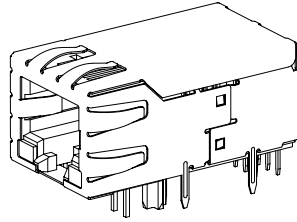
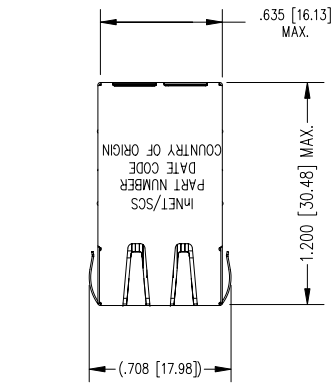

P.C.B. RECOMMENDED HOLE LAYOUT
SEEN FROM COMPONENT SIDE

ALL CENTERLINE DIMENSIONS ARE BASIC.

NOTES:

- CONNECTOR MATERIALS:
HOUSING: THERMOPLASTIC UL94 V-0
CONTACT/SHIELD: COPPER ALLOY
SHIELD PLATING: NICKEL OR TIN
CONTACT PLATING: SELECTIVE GOLD,
50 MICRO-INCHES MIN. IN CONTACT AREA.
- PIN NOT ELECTRICALLY CONNECTED MAYBE OMITTED.
SEE ELECTRICAL DRAWING FOR OMITTED PINS.
- TOLERANCES COMPLY WITH F.C.C. DIMENSION REQUIREMENTS.
- THE SUGGESTED PANEL OPENING IS INTENDED TO GIVE
USER THE ABILITY TO HAVE REASONABLE JACK/PANEL
CLEARANCES, YET MAINTAIN GROUNDING CAPABILITY.
- HIGH TEMPERATURE REFLOW COMPATABLE - 230°C/90 SEC MAX.

LED SPECIFICATION			
STANDARD LED	WAVELENGTH	* Forward V (MAX)	(TYP)
GREEN	565 nm	2.5 V	2.2 V
ORANGE	605 nm	2.5 V	2.0 V

*WITH A FORWARD CURRENT OF 20 mA

BICOLOR LED POLARITY
(ENLARGED VIEW)

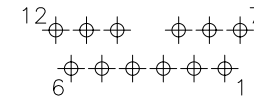
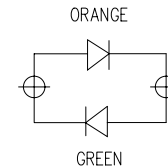

PIN IDENTIFICATION



InNet Technologies, Inc.
<http://www.innet-tech.com>



Stewart Connector Systems
<http://www.stewartconnector.com>

SHEET
3 OF 4

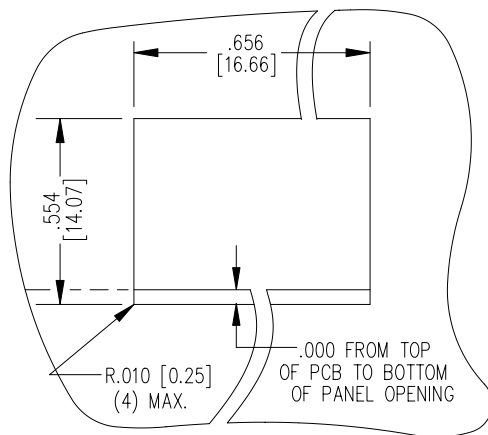

DRAWING NO.

SI-41004 REV. X

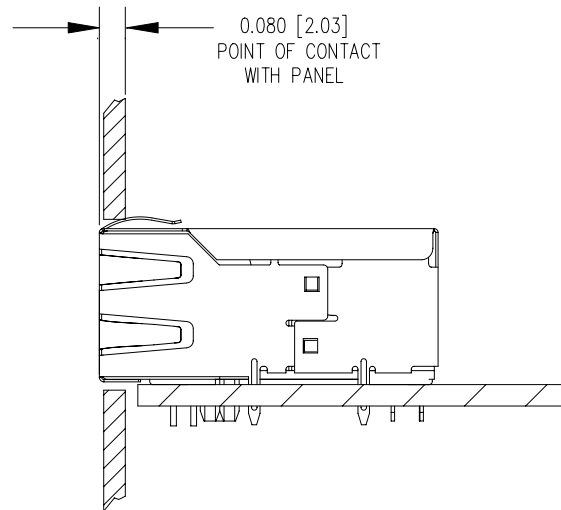

SUGGESTED PANEL OPENING



	InNet Technologies, Inc. http://www.innet-tech.com	
	 Stewart Connector Systems http://www.stewartconnector.com	
SHEET 4 OF 4	DRAWING NO. SI-41004	REV. X